

Amy Selvaraj (DELWP)

From: Andrew Helps [REDACTED]
Sent: Saturday, 30 January 2021 10:06 AM
To: Amy Selvaraj (DELWP)
Cc: [REDACTED]
Subject: The use of centrifuges
Attachments: US EPA Slpe Factors Document BFN.pdf; 8319Rev4.pdf

[REDACTED]

[REDACTED]

[REDACTED]

[REDACTED]

EXTERNAL SENDER: Links and attachments may be unsafe.

Good morning Amy,

I notice that KALBAR are now proposing to use centrifuges in their process chain. There is currently no technical data on how these centrifuges will be used – will be they be dry or wet?

What is the manpower requirement to load and unload these centrifuges and how will the involved staff be protected from the radiation.

Over the last 40 years I have performed technical due diligence on a number of rare earth element (REE) mine proposal for the World Bank, MIGA and the IFC.

A number of proposal have initially proposed using centrifuges as a part of the ore processing chain.

In all cases the problem has been the inconsistency of the input ore stream and issues with clay in that ore stream.

These ore bodies are all capable of releasing large amounts of RADON during the mining a processing operations.

A further issue with the KALBAR ore body is that there a number of Radionuclides (RADNUC'S) within the ore body.

To be fair to KALBAR, I am unsure if KALBAR lack the skills to address this issue with RADNUC's or that they are engaged in various acts act of wilful blindness.

I have been waiting for 2 years for KALBAR to publish a Radionuclide Carcinogenicity Slope factor table for their orebody.

This type of Table would be one of the first documents produced for any similar proposal in Asia, Africa, South America, USA and Europe.

I have now come to the conclusion that KALBAR lack the skills to formulate a Slope Factor Table for their ore body.

I have assembled this table as it is now obvious that KALBAR are not going to create this type of complex document.

I am happy to come into the City and go through the implications of Slope Factor spreadsheet.

Kindest Regards

Andrew Helps

[REDACTED]

[REDACTED]

Mobile [REDACTED]
UNEP Global Mercury Partnership
Waste Management Partnership - designated expert
Mercury added products and alternatives – designated expert
Mercury Fate and Transport Group

IMPORTANT PLEASE READ: This email may contain confidential and or proprietary information and may be protected by the rules of legal privilege. If you receive this email by mistake, or are not the intended recipient you must not use it or the information in any way. If this is the case, could you please inform the sender by return email or by telephoning [REDACTED] and delete any such email from your computer. This email and any attachments, has been scanned for computer viruses but you should also perform your own scan. No liability is accepted for any loss or damage, whether caused by our negligence or otherwise, that results from a computer virus or a defect in the transmission of this email or the attached file.



Radiation Exposure And Risks Assessment Manual (RERAM)

Risk Assessment Using Radionuclide Slope Factors

Review Draft Revision 2

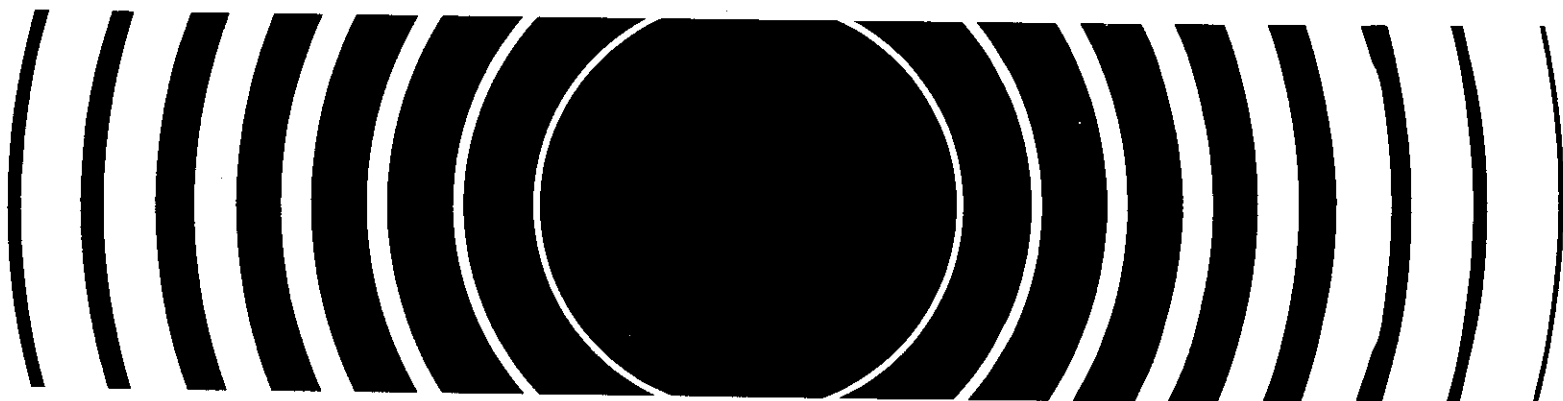

[The page contains extremely faint and illegible text, likely bleed-through from the reverse side of the document. No specific content can be transcribed.]

NOTICE

The policies set out in this document are intended solely as guidance to U.S. Environmental Protection Agency (EPA) personnel; they are not final EPA actions and do not constitute rulemaking. These policies are not intended, nor can they be relied upon, to create any rights enforceable by any party in litigation with the United States. EPA officials may decide to follow the guidance provided in this document, or to act at variance with the guidance, based on analysis of site-specific circumstances. EPA also reserves the right to change the guidance at any time without public notice.

ACKNOWLEDGMENTS

This manual was developed by the Radiation Assessment Branch of EPA's Office of Radiation and Indoor Air (ORIA). Dr. Kung-Wei Yeh served as the Work Assignment Manager. Several individuals provided valuable input regarding the content of this manual throughout its development, and their efforts are gratefully acknowledged. Special acknowledgment and appreciation are extended to Christopher Nelson, Dr. Neal Nelson, and Dr. Jerome Puskin of ORIA's Criteria and Standards Division; Bruce Means and Jim Konz of EPA's Toxics Integration Branch; and Dr. Keith Eckerman of Oak Ridge National Laboratory.

Technical assistance was provided by S. Cohen & Associates, Inc., under EPA Contract No. 68D20155, Work Assignment 4-20.

PREFACE

The *Radiation Exposure and Risk Assessment Manual (RERAM)* describes the methodology developed by EPA's Office of Radiation and Indoor Air (ORIA) to derive ingestion, inhalation, and external exposure radionuclide cancer slope factors for use in radiation risk assessment at a Comprehensive Environmental Response, Compensation, and Liability Act (CERCLA or Superfund) site. Potential users of RERAM are those involved in the remedy selection and implementation process, including risk assessors, risk assessment reviewers, remedial project managers, and other decision-makers.

EPA encourages users to provide comments on the guidance provided in this document. Comments should be sent to:

Dr. Kung-Wei Yeh
U.S. Environmental Protection Agency
Office of Radiation and Indoor Air (6603J)
401 M Street, SW
Washington, DC 20460

[This page is blank intentionally.]

EXECUTIVE SUMMARY

The U.S. Environmental Protection Agency (EPA) has developed radionuclide slope factors for estimating excess cancer risks from radioactive materials at radiologically contaminated sites managed under the Comprehensive Environmental Response, Compensation, and Liability Act (CERCLA). These radionuclide slope factors provide a methodology for evaluating radiation-induced cancer risk that is generally consistent with that used for evaluating risks from chemical carcinogens. The slope factor is an estimate of the excess probability of developing cancer per unit dose of a carcinogen over a lifetime. When multiplied by the total lifetime exposure (inhalation, ingestion, or external exposure) to a given radionuclide, the slope factor provides an estimate of the probability of developing cancer as a result of that exposure.

EPA has developed the *Radiation Exposure and Risk Assessment Manual (RERAM): Risk Assessment Using Radionuclide Slope Factors* to supplement risk assessment guidance presented in the series of publications collectively entitled *Risk Assessment Guidance for Superfund (RAGS)*. While the *RAGS* methodology specifically includes consideration of risks from radioactive contaminants, it does not provide detailed documentation of the methods used by EPA to derive the radionuclide slope factors. Since some CERCLA sites are contaminated with both radioactive materials and hazardous chemicals, EPA recommends the use of a consistent basis for evaluating cancer risks from radioactive materials and from nonradioactive hazardous chemicals. In each case, the risk to potentially exposed human receptors is computed as the product of the estimated lifetime intake or exposure for a contaminant of concern times a measure of the likelihood of excess cancer induction per unit exposure (i.e., the slope factor). The *RERAM* guidance is designed to assist risk assessors, remedial project managers, and others involved with the risk assessment and decision-making process at radiologically contaminated sites in understanding the calculations and assumptions used by EPA to estimate excess human cancer risks associated with radiation exposures.

Radionuclide slope factors express the lifetime excess cancer risk per unit exposure to a given radionuclide, where exposure is measured in units of radioactivity intake for inhalation and ingestion (pCi inhaled or ingested), or the product of soil concentration and exposure duration for external exposure [e.g., soil concentration (pCi/g) x time (y) = pCi-y/g]. The slope factor is an estimate of the lifetime excess cancer risk (fatal and nonfatal cancers) for all cancer sites, averaged over a population (all ages and both sexes). In practice, the excess cancer risk for each cancer site is estimated separately based upon organ-specific dose rates and risk coefficients, and the risks for these individual cancer sites are summed to estimate total excess risk. Dose rates to each organ may vary as a function of age and time after exposure, and the organ-specific risk coefficients may vary as a function of age and sex. Since the excess risk of cancer incidence resulting from radiation exposure may not occur until many years after exposure, it is also necessary to account for competing risks (i.e., risks from sources other than radiation exposure), through the use of vital statistics and mortality data.

The slope factor is derived from the integration of three principal types of data:

- Organ-specific dose rates for each tissue of interest (potential cancer site) over the lifetime of the exposed population, resulting from chronic exposure, at a constant rate, to a given radionuclide;
- Risk factors, which express the lifetime excess cancer incidence risk per unit dose (e.g., expected cancer cases per 10^6 rad) for specific cancer sites over the lifetime of the exposed population; and
- Vital statistics and mortality data for the reference population (currently the 1980 U.S. population), which define the survival function for an average member of the population - i.e., the probability of survival and projected years of life remaining at various ages in the reference population, taking into account competing risks (mortality risks unrelated to radiation exposure, e.g., accidents, illness).

For each age of exposure and for each cancer site considered, the excess risk of cancer at that site due to the dose accumulated at that age from a given exposure pathway is calculated by multiplying the organ-specific absorbed dose rate in that year (rad/y), the organ-specific cancer risk per unit absorbed dose at that age (rad^{-1}), and the survival function for the reference population (probability of survival to that year). The excess cancer risk for each cancer site at each age is computed in this manner and summed to obtain the total number of radiogenic cancers of all types expected in the life of the exposed population. This total is then divided by an appropriate exposure term (i.e., the total quantity of the radionuclide inhaled or ingested over a lifetime for inhalation or ingestion exposures, respectively, or the product of the radionuclide concentration in soil and exposure duration in the contaminated area for external exposures) to compute the slope factor for each exposure pathway. This procedure is followed for each radionuclide of concern. Risks from high-LET (alpha) radiation are calculated separately from those due to low-LET radiations (beta and gamma), and these are summed to obtain the slope factor for the radionuclide.

Radionuclide slope factors relate the lifetime cancer incidence risk attributable to given radionuclide exposure conditions for an average member of the reference population. This estimate of excess risk is averaged over all ages and both sexes for a population with specified mortality statistics (currently the U.S. population circa 1980). These slope factors are appropriate for assessing the average risk within this population, but are not suitable for assessing the risk to a single individual of a particular age or sex. Estimates of radiogenic cancer risk are subject to numerous sources of uncertainty, including the biokinetic and dosimetric models, tissue-specific risk factors, mortality and survival characteristics of the population, and the extrapolation of epidemiological data for populations exposed to high radiation doses to much lower levels characteristic of environmental exposures.

Radionuclide slope factor values for more than 300 radionuclides have been tabulated in EPA's *Integrated Risk Information System (IRIS)* and *Health Effects Assessment Summary Tables (HEAST)*. These radionuclide

slope factors are derived for the idealized conditions of chronic radionuclide intake or exposure, at a unit radionuclide concentration, throughout the lifetime of the exposed individuals. These slope factors can be used in conjunction with site-specific data describing the concentrations of radionuclides of concern in environmental media (e.g., air, water, vegetation, soil, and foodstuffs) and with information describing the exposure conditions (e.g., inhalation and ingestion rates; exposure times, frequencies and durations; etc.) to estimate the cancer risk from inhaling contaminated air, eating contaminated food or soil, drinking contaminated water, or from external exposure to contaminated ground surfaces for given site conditions.

Whether for inhalation, ingestion, or external exposure, the lifetime risk is related to the cumulative intake or exposure to the given radionuclide. For inhalation and ingestion, the total radioactivity (pCi) inhaled or ingested must be known. For external exposure, the soil concentration of the radionuclide of interest (pCi/g) and the total duration of exposure in the contaminated area must be known, considering the effect of shielding provided by buildings or other site features. For each radionuclide and exposure pathway, the excess cancer risk is estimated as the product of the slope factor, the exposure point concentration in pertinent environmental media, and the cumulative intake or exposure. The risks presented by each radionuclide (including radioactive decay products) and exposure pathway in a given exposure situation should be assessed separately and summed to estimate the total radiation risk.

[This page is blank intentionally.]

TABLE OF CONTENTS

Section	Page
Notice	I
Acknowledgments	ii
Preface	iii
Executive Summary	v
List of Tables	xi
List of Figures	xi

Chapter 1. Introduction

1.1	Purpose and Scope	1-1
1.2	Background - EPA Radiation Risk Assessment Methodology	1-1
1.3	Examples of the Use of Radionuclide Slope Factors	1-3
1.4	Special Considerations	1-7
1.5	Content of This Report	1-11

Chapter 2. Radionuclide Slope Factor Development

2.1	Basic Elements of Radionuclide Slope Factor Approach	2-1
2.2	Exposure Assumptions	2-5
2.3	Dosimetry Models	2-6
2.3.1	Internal Exposure - Overview of Internal Dosimetry Models	2-6
2.3.2	External Exposure - Overview of External Dosimetry Models	2-8
2.4	Cancer Risk Models	2-10
2.5	Reference Population Data: Mortality and Survival Statistics	2-12

Chapter 3. EPA Radiogenic Cancer Risk Models

3.1	Background	3-1
3.2	Cancer Risk from Low-LET Radiation	3-3
3.2.1	Dose Response Function and Dependence on Dose Rate	3-3
3.2.2	Risk Projection Models	3-5
3.2.3	EPA Assumptions for Estimating Radiogenic Cancer Risk From Low-LET Radiation	3-6
3.3	Cancer Risk from High-LET Radiation	3-13
3.3.1	Relative Biological Effectiveness	3-14

TABLE OF CONTENTS (continued)

Section	Page
3.3.2 Dose Response Function	3-15
3.3.3 Estimates of Cancer Risk from Alpha Emitters	3-15
3.3.4 Estimates of Cancer Risk from Radon Decay Products	3-16

Chapter 4. Example Calculations of Radionuclide Slope Factors

4.1 Basic Considerations	4-1
4.2 Revised Methodology For Deriving EPA Radionuclide Slope Factors	4-3
4.2.1 General Information	4-3
4.2.2 Illustrative Examples	4-5
4.3 Summary	4-10

Chapter 5. Uncertainty in Radionuclide Slope Factors

5.1 Sources of Uncertainty in Radiation Dosimetry	5-2
5.2 Sources of Uncertainty in Radiogenic Risk Models	5-4
5.3 Methods for Quantitative Uncertainty Analysis	5-6

References

References	R-1
------------------	-----

Appendices

A Radiation Dosimetry	A-1
B Attributable Mortality Risk Coefficients	B-1
C Pre-1994 EPA Radiogenic Cancer Risk Models & Slope Factors	C-1
D Calculational Methods for Radiogenic Cancer Risk Estimates	D-1

LIST OF TABLES

Table	Page
1-1 Estimates of Cancer Mortality Risk per Unit Dose of Low-LET Radiation	1-10
1-2 Comparison of Radiation Risk Estimation Methodologies: Slope Factor Approach vs. Dose-to-Risk Conversion Factor Approach	1-10
1-3 Comparison of Slope Factors for Radionuclides and Chemical Carcinogens	1-11
2-1 EPA Organ-Specific Risk Factors for Low-LET Radiation - Low Dose, Low Dose Rate	2-11
3-1 Mortality Risk Coefficients for EPA Revised Risk Methodology	3-11
3-2 EPA Revised Radiogenic Cancer Risk Coefficients - Low Dose and Low Dose Rate	3-12
4-1 Survival Function Based on 1980 Decennial Life Table Data	4-4
4-2 Attributable Cancer Risk from Uniform Low-LET Radiation	4-6
4-3 Derivation of Attributable Cancer Risk Resulting from Chronic Exposure to Gamma Radiation from Cs-137 Ground Contamination	4-8
4-4 Derivation of Attributable Cancer Risk Resulting from Chronic Inhalation of Pu-238	4-9
4-5 Derivation of Attributable Cancer Risk Resulting from Chronic Ingestion of Sr-90	4-11

LIST OF FIGURES

Figure	Page
1-1 Typical Radionuclide Exposure Pathways	1-3
1-2 Simplified Risk Equations	1-8
2-1 Basic Building Blocks Used to Calculate a Radionuclide Slope Factor	2-3
2-2 How are Radionuclide Slope Factors Derived?	2-14

[This page is blank intentionally.]

Chapter 1

Introduction

1.1 PURPOSE AND SCOPE

This document describes the methodology the U.S. Environmental Protection Agency (EPA) Office of Radiation and Indoor Air (ORIA) utilizes to assess radiation risk through the use of radionuclide slope factors. The purpose of this risk assessment guidance is to assist risk assessors, remedial project managers (RPMs), and others involved with the risk assessment and decision-making process at Superfund sites in understanding the calculations and assumptions used by the Agency to estimate human cancer risks associated with radiation exposures.

1.2 BACKGROUND—EPA RADIATION RISK ASSESSMENT METHODOLOGY

EPA has developed guidance for evaluating risks to human health and the environment from exposure to radioactive and nonradioactive hazardous substances at sites regulated under the Comprehensive Environmental Response, Compensation and Liability Act of 1980, as amended (CERCLA or "Superfund"). This guidance is documented in a series of EPA publications collectively entitled *Risk Assessment Guidance for Superfund* (RAGS). The *RAGS* methodology was developed for use in the remedial investigation/feasibility study (RI/FS) process at Superfund sites. This process, as specified in the National Oil and Hazardous Substances Pollution Contingency Plan (NCP), the implementing regulation for CERCLA (40 CFR 300), requires the selection of remedies that reduce, control, or eliminate risks to human health and the environment. The *RAGS* methodology provides the framework for assessing baseline risks, developing and refining preliminary remediation goals, and evaluating risks associated with various remedial action alternatives.

The *Risk Assessment Guidance for Superfund* considers two general categories of risk to human health—carcinogenic risk and noncarcinogenic risk. However, in evaluating exposure to radioactive materials at contaminated sites, only carcinogenic risk is considered for most radionuclides. Other types of detrimental health effects that can also be associated with exposure to ionizing radiation include mutagenic, teratogenic, and acute toxicity effects. However, these effects are generally less significant for doses associated with environmental exposures. Therefore, EPA considers carcinogenic risk to be a sufficient basis for assessing radiation-related human health risks at Superfund sites.

Previous EPA risk assessment guidance (EPA86) did not specifically address radioactive materials. Traditionally, risks associated with exposure to radioactive materials and chemical hazards have been evaluated using different methods. Since some CERCLA sites are contaminated with both radioactive materials and hazardous chemicals, EPA recommends an approach for evaluating radiation-induced cancer risks that is

generally consistent with that used for evaluating cancer risks from nonradioactive hazardous chemicals. In each case, the risk to potentially exposed human receptors is computed as the product of the estimated lifetime intake or external exposure¹ for a contaminant of concern times a measure of the likelihood of incremental cancer induction per unit exposure to that contaminant, termed the slope factor. The slope factor is an estimate of the probability of a response—i.e., the probability of an individual developing cancer per unit intake of, or external exposure to, a carcinogen over a lifetime; when multiplied by an estimate of the total lifetime intake or external exposure, it may be used to estimate the probability of an individual developing cancer as a result of that exposure.

Radionuclide slope factors are central estimates (i.e., approximately median or 50th percentile values) of the age-averaged, lifetime cancer incidence (fatal and nonfatal cancer) risk per unit inhalation, ingestion, or external exposure to a specific radionuclide. Values for more than 300 radionuclides have been tabulated in EPA's Integrated Risk Information System (IRIS)(EPA96) and Health Effects Assessment Summary Tables (HEAST)(EPA95). Ingestion and inhalation slope factors are central estimates of the age-averaged, lifetime cancer incidence risk per unit of activity inhaled or ingested, expressed as risk per picocurie of a radionuclide inhaled or ingested (risk/pCi). External exposure slope factors are central estimates of lifetime cancer incidence risk for each year of exposure to external radiation from photon-emitting radionuclides distributed uniformly in a thick layer of soil, and are expressed as risk/year per picocurie/gram of the radionuclide in soil (risk per pCi-y/g). (See Appendix A for definitions of radiation units.)

Slope factors are used for several different purposes during various stages of the Superfund remedial action process. For example, during the site assessment phase, slope factors are used in EPA's Hazard Ranking System (HRS) to assign toxicity factor values to radionuclides for the purpose of calculating site scores. During the remedial investigation and feasibility study (RI/FS), slope factors are used to determine baseline site risk, to develop preliminary remediation goals, and to evaluate remedial alternatives.

In addition to this document, further discussion of the application of radionuclide slope factors in risk evaluations may be found in the following EPA documents:

- Hazard Ranking System (HRS), Federal Register (55 FR 515320), December 1990 (EPA90).
- *Risk Assessment Guidance for Superfund; Volume I - Human Health Evaluation Manual* (RAGS), Part A, Baseline Risk Assessment, EPA/540/1-89/002 (EPA89a).
- *Risk Assessment Guidance for Superfund; Volume I - Human Health Evaluation Manual* (RAGS), Part B, Development of Risk-Based Preliminary Remediation Goals, OSWER Directive 9285.7-01B (EPA91a).
- *Risk Assessment Guidance for Superfund; Volume I - Human Health Evaluation Manual* (RAGS), Part C, Risk Evaluation of Remedial Alternatives, OSWER Directive 9285.7-01C, (EPA91b).

¹Applies only to radionuclides that emit gamma radiation or x-rays (see Appendix A).

1.3 EXAMPLES OF THE USE OF RADIONUCLIDE SLOPE FACTORS

Radionuclide slope factors can be used to estimate the lifetime incremental cancer incidence risk attributable to a given radionuclide exposure for an average member of an exposed population. The slope factors are used in conjunction with site-specific data describing the concentrations of radionuclides of concern in environmental media (e.g., air, water, vegetation, soil, and foodstuffs) and with information describing the exposure conditions (e.g., inhalation and ingestion rates, exposure times, frequencies and durations, etc.) to estimate the cancer risk from inhaling contaminated air, eating contaminated food or soil, drinking contaminated water, or from external exposure to contaminated ground surfaces.

Exposure assessment for radionuclides is very similar to that for hazardous chemicals. The goal of the exposure assessment is to estimate exposure point concentrations of the radionuclides of concern in environmental media, and to estimate potential intakes or external exposures to potential receptors. This may include direct measurements of environmental concentrations and/or mathematical modeling of radionuclide fate and transport in the environment. Typical radionuclide exposure pathways are depicted in Figure 1-1.

Figure 1-1. Typical Radionuclide Exposure Pathways

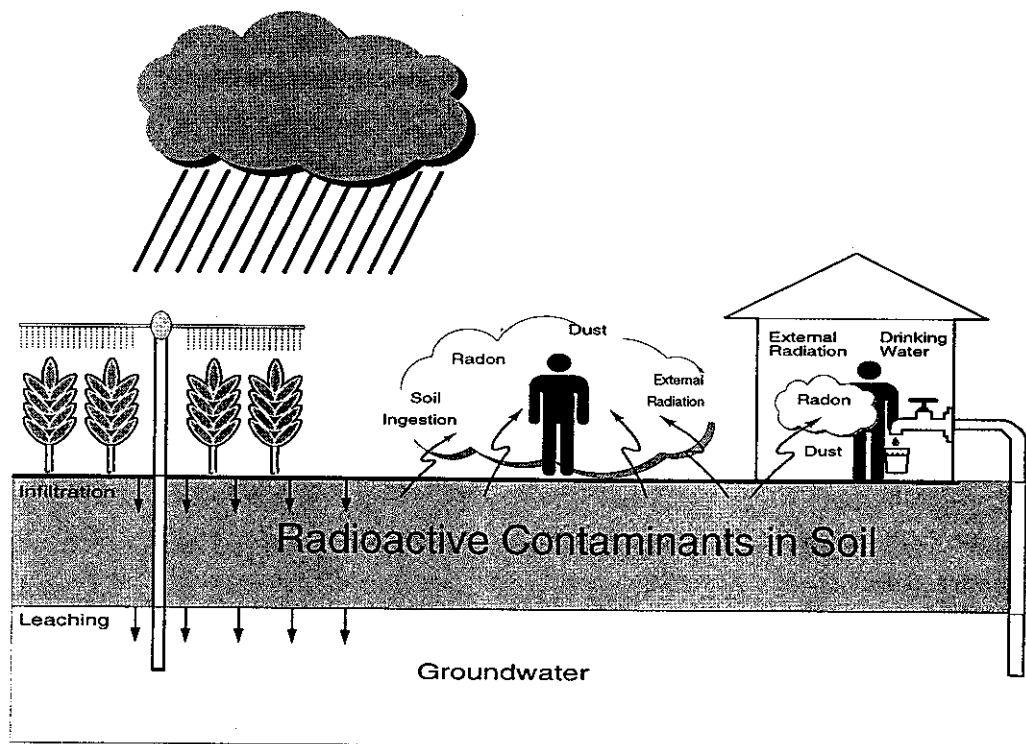

All radionuclides, by definition, undergo radioactive decay in which the radionuclide is transformed in atomic number, mass, or excitation state. In many cases, the resulting decay products may also be radioactive and undergo further decay. Consideration of all potential radioactive decay products is a key element of the exposure assessment for radionuclides. Decay products may have different physical and chemical characteristics that affect their environmental fate and transport, as well as different radiotoxicity characteristics. The radiation dose estimates used to calculate EPA's radionuclide slope factors explicitly consider the production of radioactive decay products within the body following inhalation or ingestion; the dose estimates for external exposure, however, do not include contributions from radioactive decay products. In each case, it is important that the exposure assessment address the intake of, or external exposure to, multiple members of a radioactive decay chain, where appropriate.

For selected radionuclides where contributions to dose and risk from short-lived radioactive decay products may be particularly significant, EPA's tabulations of radionuclide slope factors include entries with the suffix "+D" (e.g., Ra-226+D, Cs-137+D); these slope factors explicitly incorporate the contribution to cancer risk from decay chain members with radioactive half-lives less than 1 year (i.e., all decay chain members from the parent radionuclide down to, but not including, the next radionuclide in the decay chain with a radioactive half-life longer than 1 year), by assuming equivalent concentrations with the parent radionuclide in the environment (i.e., secular equilibrium). This presumption of equilibrium may or may not be appropriate for a given set of site conditions, and, where available, site-specific analytical data and models should be used to establish the actual degree of equilibrium between each parent radionuclide and its decay products in each medium sampled, rather than relying on these "+D" values. In some cases, it may be necessary to consider the combination of risks from exposures to a parent radionuclide and its decay products over several sequential subchains (e.g., Ra-226+D and Pb-210+D).

Whether for inhalation, ingestion, or external exposure, the lifetime risk is related to the cumulative intake or exposure to the given radionuclide. For inhalation and ingestion, the total activity (pCi) inhaled or ingested must be known. For external exposure, the soil concentration of the radionuclide of interest (pCi/g) and the total duration of exposure in the contaminated area must be known, considering the effect of shielding provided by buildings or other site features. It should be emphasized that slope factors relate the lifetime, age-averaged risk to the total exposure regardless of the time period over which the exposure occurs.

Three examples are presented below to illustrate the use of radionuclide slope factors in risk assessments—one each for inhalation, ingestion, and external exposure. In an actual risk assessment, each pathway should be assessed in greater detail, taking into account occupancy, building shielding, eating and drinking habits, and sources of food and water.

The risks presented by each radionuclide in a given exposure situation must be assessed separately and summed to estimate the total radiation risk. Normally, only a few radionuclides may dominate the radiological

risks at a particular site. For the purposes of the following examples, however, it is assumed that exposure is limited to a single radionuclide, and its radioactive decay products where appropriate.

External Exposure

For external exposure, we consider the case of the constant exposure to gamma rays emanating from soil contaminated by Cs-137 to a level of 1 pCi/g. Approximately 94.6% of all Cs-137 atoms undergo radioactive decay by beta emission to produce Ba-137m, while the remaining 5.4% of Cs-137 atoms decay to produce nonradioactive Ba-137; the half-life for radioactive decay of Cs-137 is 30.17 years. For the purposes of this example, Cs-137 is assumed to be in secular equilibrium with Ba-137m (i.e., 0.946 pCi/g of Ba-137m is assumed to be present in soil along with the 1 pCi/g of Cs-137). For a given radionuclide, the contribution to dose from radioactive decay products (if any) is not incorporated into the external dose estimates or the derived radionuclide slope factors for external exposure; therefore, the effect of any radioactive decay products must be considered by summing the appropriate slope factors for each radionuclide in the decay series. Alternatively, for some radionuclides where the impact of radioactive decay products is considered particularly significant, EPA has developed slope factors for both the individual radionuclides and for the radionuclide plus its short-lived decay products; in the tabulations of radionuclide slope factors, the later cases are designated by the suffix "+D" following the radionuclide name. For example, the radionuclide slope factors for Cs-137+D represent a composite of the values for Cs-137 and its daughter, Ba-137m; this distinction is particularly important for this example because Ba-137m is a gamma-emitter, while Cs-137 is a pure beta emitter.

The slope factor for external exposure to Cs-137+D in soil is taken as 2.09×10^{-6} per pCi-yr/g of Cs-137 in the soil (EPA95). The lifetime attributable cancer risk to a hypothetical individual who occupies this site for 12 hours/day over a period of 30 years is then:

$$\begin{aligned} \text{Attributable Cancer Risk} &= \text{Slope Factor} \times \text{Concentration} \times \text{Exposure Time} \\ &= 2.09 \times 10^{-6} \text{ per pCi-y/g} \times 1 \text{ pCi/g} \times 30 \text{ y} \times 0.5 \\ &= 3 \times 10^{-5}, \end{aligned}$$

where 0.5 represents the site occupancy factor (i.e., 12 hours/day / 24 hours/day).

It should be noted that the radionuclide slope factors for external exposure are derived assuming soil contaminated constantly and uniformly to an infinite extent in depth and area. Risk estimates based on these assumptions may be overly conservative for situations where the contamination is of limited areal extent and/or depth, or located at some depth below the ground surface, etc.; furthermore, depletion of the radionuclide concentration in soil due to radioactive decay or soil erosion is not considered in these slope factors, which may also lead to conservative estimates of risk. To obtain more accurate estimates of risk, the slope factors should be used in conjunction with the best available estimate of exposure conditions. Environmental fate and

transport models which explicitly consider radioactive decay, deposition, erosion, site geometry and shielding effects, and other important factors, may be used to estimate such exposures.

Inhalation Exposure

For inhalation, we consider an average individual exposed to air in which the measured concentration of Sr-90 is 1 pCi/m³. For this example, the slope factor for inhalation of Sr-90+D (i.e., Sr-90 in secular equilibrium with its radioactive decay product, Y-90) is taken to be 6.93 x 10⁻¹¹ pCi⁻¹ (EPA95). Assuming an average exposed individual inhales a volume of 20 m³ of contaminated air per day for 250 days/year over a period of 7 years, the lifetime attributable cancer risk is estimated as:

$$\begin{aligned} \text{Attributable Cancer Risk} &= \text{Slope Factor} \times \text{Concentration} \times \text{Cumulative Intake} \\ &= 6.93 \times 10^{-11} \text{ pCi}^{-1} \times 1 \text{ pCi/m}^3 \times 20 \text{ m}^3/\text{day} \times \\ &\quad 250 \text{ days/y} \times 7 \text{ y} \\ &= 2 \times 10^{-6}. \end{aligned}$$

The dose to body organs from inhalation of strontium, like many radionuclides, may differ depending on the physical and chemical characteristics of the inhaled compound or carrier. For example, SrTiO₃ is retained in the lung for an extended period (ICRP lung clearance class Y), whereas other compounds are cleared much more rapidly (ICRP lung clearance class D). Radionuclide slope factors are provided in IRIS and HEAST, however, for only a single default case for each radionuclide - typically the most commonly encountered or most conservative compound (i.e., the chemical form which results in the maximum dose per unit activity inhaled). In this example, the slope factor for Sr-90+D assumes the ICRP lung clearance class D. Similarly, the dose may vary as a function of the physical size of the inhaled particulate. In the development of radionuclide slope factors, the size distribution for all particulates has been specified as the activity median aerodynamic diameter (AMAD) of 1 micron. (Exceptions include radionuclides, such as radon, which exist in gaseous form under normal conditions.) For exposure situations where the default parameters may not be appropriate, users should contact the Remedial Guidance Section of ORIA at EPA-HQ. *[Note that the ICRP lung clearance class values specified for the radionuclide slope factors are provided for reference only, and should not be used to correct, modify, or in any way adjust the radionuclide slope factors or intake assumptions in the risk calculations.]*

Ingestion Exposure

For ingestion, we consider an average individual exposed to drinking water contaminated by Pu-238 at a concentration of 1 pCi/liter. The slope factor for ingestion of Pu-238 is taken to be 2.95 x 10⁻¹⁰ pCi⁻¹ (EPA95). Assuming an ingestion rate of 2 liters/day, 350 days/year for a period of 30 years, the lifetime attributable cancer risk is estimated as:

$$\begin{aligned}
\text{Attributable Cancer Risk} &= \text{Slope Factor} \times \text{Concentration} \times \text{Cumulative Intake} \\
&= 2.95 \times 10^{-10} \text{ pCi}^{-1} \times 1 \text{ pCi/L} \times 2 \text{ L/day} \times 350 \text{ days/y} \\
&\quad \times 30 \text{ y} \\
&= 6 \times 10^{-6} .
\end{aligned}$$

Similar to the situation noted for inhalation exposures, the dose from ingestion of plutonium and other radionuclides may vary depending on the chemical characteristics of the ingested compound. For ingestion, this is expressed through the gastrointestinal (GI) tract absorption fraction, f_1 , which represents the fraction of activity that is absorbed from the GI-tract (typically only absorption from the small intestine is assumed) to blood. For radionuclides which may have different values of f_1 depending on the chemical form of the ingested material, the radionuclide slope factors are typically specified in IRIS and HEAST only for the most conservative case. For Pu-238, EPA specifies a slope factor only for $f_1=10^{-3}$ (EPA95). However, both EPA (EPA88) and ICRP (ICRP86) recommend compound-dependent f_1 values of 10^{-5} for oxides, 10^{-4} for nitrates, and 10^{-3} for other compounds or unknown mixtures of plutonium. For exposure situations where the default parameters assumed for calculation of the slope factors may not be appropriate, users should contact the Remedial Guidance Section of ORIA at EPA-HQ. *[Note that the GI absorption factor (f_1) values specified for the radionuclide slope factors are provided for reference only, and should not be used to correct, modify, or in any way adjust the radionuclide slope factors or intake assumptions in the risk calculations. This differs from the application of similar factors for chemical slope factors.]*

Simplified equations for estimating excess cancer risk from exposure to radionuclides via inhalation, ingestion, and external exposure to contaminated soil are presented in Figure 1-2. These simplified equations are presented for illustrative purposes only. In an actual risk assessment for a contaminated site, an exposure assessment would be conducted to determine the appropriate exposure pathways and exposure parameters for use in estimating cumulative lifetime intake and external exposure to each radionuclide of concern.

1.4 SPECIAL CONSIDERATIONS

As discussed in the previous sections, radionuclide slope factors can be used to estimate excess cancer risks resulting from radionuclide exposures in a manner analogous to that used for chemical contaminants at Superfund sites—i.e., the estimates of lifetime intake/exposure from the exposure assessment are coupled with the appropriate slope factors for each radionuclide and exposure pathway. The sum of the risks from all radionuclides in all exposure pathways yields the lifetime cancer risk attributable to radiation exposure. This approach differs from the method traditionally used to estimate radiation risk. Also, the radionuclide slope factors differ from slope factors used to estimate chemical risks. These special considerations are discussed below.

Figure 1-2. Simplified Risk Equations *

External: $\text{Risk}_{i,\text{ext}} = \text{SF}_{i,\text{ext}} \times C_{i,\text{soil}} \times \text{EF} \times \text{ED} \times \text{AF}$

Inhalation: $\text{Risk}_{i,\text{inh}} = \text{SF}_{i,\text{inh}} \times C_{i,\text{air}} \times \text{IR}_{\text{inh}} \times \text{EF} \times \text{ED} \times \text{AF}$

Ingestion: $\text{Risk}_{i,\text{ing}} = \text{SF}_{i,\text{ing}} \times C_{i,\text{ing}} \times \text{IR}_{\text{ing}} \times \text{EF} \times \text{ED} \times \text{AF}$

where,

- $\text{Risk}_{i,p}$ = Lifetime excess cancer risk from radionuclide *I* and pathway *p*
 $\text{SF}_{i,p}$ = Slope factor for radionuclide *I* and pathway *p* (risk per pCi inhaled or ingested, or risk/y per pCi/g in soil for external exposure)
 $C_{i,\text{soil}}$ = Concentration of radionuclide *I* in soil (pCi/g)
 $C_{i,\text{air}}$ = Concentration of radionuclide *I* in air (pCi/m³)
 $C_{i,\text{ing}}$ = Concentration of radionuclide *I* in ingested material [e.g., drinking water (pCi/L), contaminated food products (pCi/g), etc.]
 IR_{inh} = Inhalation rate (m³/day)
 IR_{ing} = Ingestion rate (g/day for soil or food products, L/day for water)
 EF = Exposure frequency (days/year)
 ED = Exposure duration (years)
 AF = Adjustment factor for site-specific conditions (unitless)[e.g., radiation shielding, indoor/outdoor exposure time, indoor/outdoor dust filtration, etc.]

Radionuclide Slope Factors vs Dose

Traditionally, impacts from exposure to radioactive materials have been expressed in terms of dose. (See Appendix A for a discussion of radiation dosimetry concepts and terminology—for the purpose of this discussion, the term “dose” is used in a generic sense, rather than “absorbed dose” and “dose equivalent”.) Most radiation protection standards and requirements are specified in terms of a radiation dose limit (e.g., mrem/y) that may be allowable from a particular exposure source and/or exposure pathway.

Dose conversion factors (DCFs) for radionuclides represent the dose per unit intake or external exposure. DCFs may be specified for specific body organs of interest, or as a weighted sum of individual organ doses, termed the effective dose. These DCFs may be multiplied by the total activity of each radionuclide inhaled or ingested per year or the external exposure to estimate the radiation dose to a receptor, in a manner analogous to the use of the radionuclide slope factors for estimating risk. EPA-approved DCFs for inhalation and ingestion exposure are published in Federal Guidance Report No. 11 (EPA88), and DCFs for external exposure are published in Federal Guidance Report No. 12 (EPA93).

Prior to the development of the radionuclide slope factors, cancer risk from radiation exposure was traditionally estimated by multiplying the radiation dose computed using the DCFs by an estimate of the cancer risk per unit dose (e.g., risk per person-rad), which is averaged over all organs and tissues. Recent estimates of the dose-to-risk conversion factor are shown in Table 1-1. EPA does not recommend this method, and estimates of risk computed using this method are generally greater than those computed using the slope factor method; the magnitude of this discrepancy depends on the particular radionuclides and exposure pathways for the site-specific conditions, but can range from less than a factor of two to approximately one order of magnitude. These differences may be attributed to factors such as the consideration of competing mortality risks and age-dependent radiation risk models in the development of the slope factors, different distributions of relative weights assigned to individual organ risks in the two methods, and differences in dosimetric and toxicological assumptions. Some of these key differences are summarized in Table 1-2.

In evaluating sites contaminated with radioactive materials, it is generally useful to estimate both radiation dose and health risk. DCFs should be used to compute radiation doses resulting from site-related exposures for comparison with radiation protection standards and dose limits, and radionuclide slope factors should be used to estimate cancer risk from radionuclide exposure to compare with EPA's target risk range (i.e., 10^{-4} to 10^{-6} lifetime excess cancer risk) for cleanup.

Comparison of Slope Factors for Radionuclides and Chemicals

At sites contaminated with both radionuclides and hazardous chemicals, the risks from both types of contaminants should be considered to assess overall site conditions. However, risk estimates for radionuclides and chemical contaminants should be assessed and presented separately in the risk characterization. Care should be exercised in combining radiation and chemical risk estimates. The risk estimates for radionuclides and chemicals may relate to different cancer endpoints, and slope factors for radionuclides and chemicals incorporate several differences that may result in incompatibility; some of these differences are summarized in Table 1-3.

For hazardous chemicals, evaluation of both carcinogenic and noncarcinogenic risks may be required. For radionuclides, however, cancer risks generally will be limiting, and provide a sufficient basis for assessing radiation-related human health risks at contaminated sites. One exception is uranium: for uranium, a kidney toxin, chemical toxicity may be as important as, or more important than, radiotoxicity. For uranium, EPA recommends consideration of both carcinogenic risk using the radionuclide slope factors and also noncancer risk due to chemical toxicity using the reference dose.

Current knowledge of carcinogenesis from low-level exposures to radiation or chemicals in the environment is very uncertain, and it is not known whether the impacts from multiple contaminants may be additive, synergistic or antagonistic. However, in the absence of additional information, it is reasonable to assume that

Table 1-1. Estimates of Cancer Mortality Risk per Unit Dose of Low-Level Low-LET Radiation

Source	Fatal Cancer Risk (per 10 ⁶ person-rad) ^a	Comments
EPA94a ^b	509	Incorporates a DDREF = 1 for breast and a DDREF = 2 for other sites.
ICRP91	500	Incorporates a DDREF = 2.
NAS90	800	No DDREF incorporated (i.e., DDREF = 1); however, a DDREF = 2 to 10 is suggested for low-level exposures.
EPA89b ^c	392	No DDREF incorporated (i.e., DDREF = 1).
UNSC88	710	No DDREF incorporated (i.e., DDREF=1); however, a DDREF = 2 to 10 is suggested for low-level exposures.
St88	450	Incorporates a DDREF = 2 for breast and a DDREF = 3 for other sites
NAS80	67-403	Incorporates a DDREF = 1 for the upper limit and a DDREF = 2.48 for the lower limit.

(a) Cancer risk per 10⁶ person-rem for ICRP (1991). (b) Current EPA estimate - see Chapters 2-3 and Appendix D. (c) Pre-1994 EPA estimate - see Appendix C. DDREF = Dose and dose rate effectiveness factor.

Table 1-2. Comparison of Radiation Risk Estimation Methodologies: Slope Factor Approach vs. Dose-to-Risk Conversion Factor Approach

Parameter	Slope Factor Approach	Dose-to-Risk Conversion Factor Approach (Effective Dose Equivalent x Risk Factor)
Competing Risks	Persons dying from competing causes of death (e.g., disease, accidents) are not considered susceptible to radiation-induced cancer. Probability of dying at a particular age from competing risks is considered based on the mortality rate from all causes at that age in the 1979-1981 U.S. population.	Competing risks are not considered explicitly. (In some cases, they may be incorporated into the derivation of the risk factor—e.g., EPA94a.)
Risk Models	Age-dependent and sex-dependent risk models for 14 cancer sites are considered individually and integrated into the slope factor estimate.	Risk estimate averaged over all ages, sexes, and cancer sites.
Genetic Risk	Genetic risk is not considered in the slope factor estimates; however, ovary is considered as a potential cancer site.	Effective dose equivalent value includes genetic risk component.
Dose Estimates	Low-LET and high-LET dose estimates considered separately for each target organ.	Dose equivalent includes both low-LET and high-LET radiation, multiplied by appropriate Relative Biological Effectiveness (RBE) factors (see below).
RBE for alpha radiation	20 for most sites (8 prior to 1994) 10 for breast (8 prior to 1994) 1 for leukemia (1.117 prior to 1994)	20 (all sites)
Organs Considered	Estimates of absorbed dose to 16 target organs/ tissues considered for 13 specific cancer sites plus residual cancers.	Effective Dose Equivalent (ICRP79) considers dose estimates to 6 specified target organs plus remainder (weighted average of 5 other organs). Effective dose (ICRP91) considers dose estimates to 12 specified target organs plus remainder (average of 10 other organs).
Lung Dose Definition	Absorbed dose used to estimate lung cancer risk computed as weighted sum of dose to tracheobronchial region (80%) and pulmonary lung (20%).	Average dose to total lung (mass weighted sum of nasopharyngeal, tracheobronchial, and pulmonary regions).
Integration Period	Variable length (depending on organ-specific risk models and consideration of competing risks) not to exceed 110 years.	Fixed integration period of 50 years typically considered.
Dosimetric/ Metabolic Models	Metabolic model parameters for dose estimates generally follow ICRP Publication 30 (ICRP79) recommendations; exceptions include transuranic radionuclides (Su81).	Typically employ ICRP [Publication 30 (ICRP79) and/or Publication 60 (ICRP91)] models and parameters for radionuclide uptake, distribution, and retention.

Table 1-3. Comparison of Slope Factors for Radionuclides and Chemical Carcinogens

Parameter	Radionuclide Slope Factor	Chemical Slope Factor
Endpoints Considered	<ul style="list-style-type: none"> • Carcinogenic risk only (i.e., cancer as the cause of death); however, for uranium only, noncarcinogenic risk is considered separately, by comparison to its Reference Dose (RfD) 	<ul style="list-style-type: none"> • Tumorigenic risk only; however, for some chemicals, noncarcinogenic risks are considered separately using appropriate RfD values
Dose-Response Model	<ul style="list-style-type: none"> • Linear non-threshold model • Extrapolated from high dose exposures 	<ul style="list-style-type: none"> • Linear non-threshold model • Extrapolated from high dose exposures
Epidemiological Basis	<ul style="list-style-type: none"> • Risk estimates based primarily on human epidemiological data 	<ul style="list-style-type: none"> • Risk estimates typically based primarily on animal studies, with little human data
Statistical Level	<ul style="list-style-type: none"> • Central estimate of mean 	<ul style="list-style-type: none"> • 95% upper confidence limit on the mean
Mechanism of Cellular Damage	<ul style="list-style-type: none"> • Physical energy released during radioactive decay ionizes biological tissue, producing free radicals 	<ul style="list-style-type: none"> • Chemical action produces free radicals
Exposure Routes	<ul style="list-style-type: none"> • Ingestion of water, soil, and food products • Inhalation of particulates and gases (radon) • External gamma exposure 	<ul style="list-style-type: none"> • Ingestion of water, soil, and food products • Inhalation of particulates and volatiles • Dermal absorption on contaminants on skin
Special Considerations	<ul style="list-style-type: none"> • Radioactive decay and ingrowth of radioactive decay products: individual radionuclide concentrations may decrease or increase with time • Natural background is ubiquitous at levels exceeding typical risk targets; natural variability in background may swamp ability to distinguish small increments due to contamination 	<ul style="list-style-type: none"> • Degradation products may include other carcinogens. • Background levels in the environment typically low
Uncertainties	<ul style="list-style-type: none"> • For both chemicals and radionuclides, extrapolation from high dose and high dose rate exposure is generally required to estimate risks of low-level exposures; this extrapolation typically constitutes one of the greatest sources of uncertainty. For chemical carcinogens additional uncertainty may be introduced due to extrapolation of animal data to humans. Slope factors for both radionuclides and chemicals are used to estimate incremental cancer risk, which typically represents a small increment over a relatively high baseline incidence. 	

excess cancer risks are additive for purposes of evaluating the overall potential human health hazard associated with a contaminated site.

1.5 CONTENT OF THIS REPORT

The remainder of this report is organized as follows:

- Chapter 2 presents an overview of EPA's method of developing radionuclide slope factors. It summarizes the integration of dosimetric and health effects models, with consideration of competing risks, to estimate age-averaged excess lifetime cancer risk. *[NOTE: In 1994, EPA adopted a revised methodology for estimating radiogenic cancer risk and the calculation of radionuclide slope factors; this new methodology is discussed in the body of this report. Similar information for the previous methodology, used for estimating radiogenic cancer risk and radionuclide slope factors prior to 1994 is presented in Appendix C.]*
- Chapter 3 presents a more detailed discussion of currently-recommended EPA models for estimating cancer risk per unit radiation dose. Appendix C provides similar information on previously-recommended EPA risk models.

- Chapter 4 presents detailed numerical examples of the methods used to estimate cancer risks and slope factors.
- Chapter 5 presents a brief overview of some of the important sources of uncertainty in the assessment of risks from radionuclide exposures.
- Appendix A presents a summary of the models used for estimation of doses resulting from internal and external exposures to radionuclides.
- Appendix B presents compilations of the attributable mortality risk coefficients used for developing the radionuclide slope factors.
- Appendix C presents information on the methodology used by EPA for estimating radiogenic cancer risk and radionuclide slope factors prior to adoption of the revised methodology in 1994. Appendix C also includes numerical examples of the slope factor derivation using this previous methodology, corresponding to those presented in Chapter 4 for the revised methodology.
- Appendix D presents calculational details of the radiogenic cancer risk models currently used by EPA for derivation of the radionuclide slope factors (adapted from EPA94a).

Chapters 1 and 2 provide a general introduction to the radionuclide slope factors used by EPA for evaluating radiation risks; this discussion is intended to address the needs of most readers in understanding the interpretation and application of radionuclide slope factors. Chapter 3 presents additional discussion of the radiogenic cancer risk models used in the development of the radionuclide slope factors; similar information for the previous risk models (prior to 1994) is presented in Appendix C. Chapter 4 presents a series of illustrative examples which may be helpful in understanding the calculational mechanics of the slope factor derivation; corresponding examples for the methodology used by EPA for deriving slope factors prior to 1994 are presented in Appendix C. The discussion of uncertainties in Chapter 5 also should be of broad interest. The summary of radiation dosimetry concepts and models in Appendix A is provided for reference purposes, but is not essential to an understanding of the radionuclide slope factors. Similarly, the tabulations of risk coefficients in Appendix B are provided for reference purposes only. Appendix D is very mathematically oriented, and may be of limited interest, primarily to individuals desiring a more complete understanding of the calculational mechanics of the radiogenic risk factor development.

Chapter 2

Radionuclide Slope Factor Development

Chapter 2 presents an overview of the concepts and methods used to derive the radionuclide slope factors. More complete discussions of the radiogenic cancer risk models, mathematical details of the calculational methods, and examples of radionuclide slope factor development are provided in later chapters.

2.1 BASIC ELEMENTS OF RADIONUCLIDE SLOPE FACTOR APPROACH

The slope factor is an estimate of the incremental probability of developing cancer per unit dose/exposure of a carcinogen over a lifetime. When multiplied by the total lifetime dose/exposure, the slope factor can be used to estimate the probability of developing cancer as a result of that exposure.

Radionuclide slope factors are central estimates of the age-averaged, lifetime attributable cancer incidence (fatal plus nonfatal cancer) risk per unit intake or external exposure to a specified radionuclide. EPA has developed slope factors for estimating incremental cancer risks resulting from exposure to radionuclides via inhalation, ingestion, and external exposure pathways. Ingestion and inhalation slope factors are central estimates of the age-averaged, lifetime attributable cancer incidence risk per unit of activity inhaled or ingested (risk/pCi). External exposure slope factors are central estimates of lifetime attributable cancer incidence risk for each year of exposure to external radiation from photon-emitting radionuclides distributed uniformly in a thick layer of soil (risk per year of exposure per pCi/g in soil). These values may be combined with site-specific media concentration data and exposure assumptions to estimate lifetime attributable cancer risks to current or future receptors at a site from radionuclide exposures. Slope factors for radionuclides are published by EPA in IRIS (EPA96) and HEAST (EPA95).

The slope factors for radionuclides are based primarily on epidemiological data on human populations exposed to high levels of "low-LET" (see Appendix A) ionizing radiation (high doses delivered at high dose rates). For extrapolation of these data to the much lower doses typical of environmental radiation exposures, EPA assumes that, for low-LET radiation, the risk per unit dose is reduced by a factor of two for all cancer sites except breast. In the range of environmental exposures, EPA assumes a linear non-threshold dose-response model - i.e., that no lower threshold exists for radiation carcinogenesis, such that any level of exposure may be associated with some probability of incremental cancer incidence. However, since the cancer risk is stochastic (i.e., statistical or probabilistic) in nature, it is not possible to determine which cancers in an exposed population are caused by radiation exposures. The extrapolation of epidemiological data for populations exposed at high radiation doses and dose rates to much lower levels characteristic of environmental exposures is a significant source of uncertainty in determining risks from low-level radiation.

Radionuclide slope factors relate the lifetime cancer incidence risk attributable to given radionuclide exposure conditions for an average member of an exposed population. This estimate of attributable risk is averaged over age and sex for a reference population with specified mortality statistics. The slope factors estimate the average risk within this population, but may not accurately indicate the risk to a single individual of a particular age or sex. These estimates are only applicable under conditions where the incremental radiation-induced risks do not appreciably alter the survival statistics of the reference population, i.e., where the radiation-induced risks are very small relative to the competing risks experienced by the population; this condition is satisfied under typical environmental radiation exposure situations.

Radionuclide slope factors are used to estimate the risk of developing cancer from exposure to a given radionuclide under specific exposure conditions. Principal exposure parameters to be considered include: (i) the radionuclide concentrations in air, soil, water and foodstuffs; (ii) intake factors such as breathing rates, and drinking and eating habits; and (iii) exposure time, frequency, and duration.

The lifetime attributable cancer risk to the average individual from exposure to a given radionuclide is computed as the number of radiation-attributable cancer cases expected in a uniformly exposed population divided by the size of the population (or alternatively, the probability of a radiation-induced cancer in the average member of the population). This estimate of lifetime attributable cancer risk is then divided by an appropriate exposure term (i.e., the total activity inhaled or ingested over a lifetime or the product of the radionuclide concentration in soil and occupancy time in the contaminated area for external exposures) to compute the slope factors for each pertinent exposure pathway.

In EPA's development of radionuclide slope factors, the size of the exposed population (or alternatively, the probability of survival of an average member of the population) is allowed to decrease over time to account for competing risks of death (i.e., risks other than radiation exposure). This is accomplished by the use of an actuarial "life table" based on age-specific mortality data, which provides the number of survivors of an original population (or alternatively, the probability of survival for an average individual of that population, termed the "survival function") on an annual basis.

The basic calculational elements used to derive a radionuclide slope factor are depicted in Figure 2-1 and summarized below:

- Specific exposure assumptions are used to calculate dose rates in various body organs of interest. Exposures may occur by inhaling or ingesting radionuclides (internal exposures) or by absorbing gamma rays that emanate from radionuclides in the soil (external exposure). Exposure rates are expressed in terms of the rate of inhalation or ingestion (pCi/y) for internal exposures, or in terms of the concentration of radionuclides in the soil (pCi/g) and occupancy in the contaminated area for external exposures. Constant unit exposure rates are assumed—i.e., each member of the exposed population is assumed to inhale or ingest a unit activity of the radionuclide of interest per year, or to be continuously exposed to a unit concentration of the radionuclide in soil.

Figure 2-1. Basic building blocks used to calculate a radionuclide slope factor.

Radiation risk:

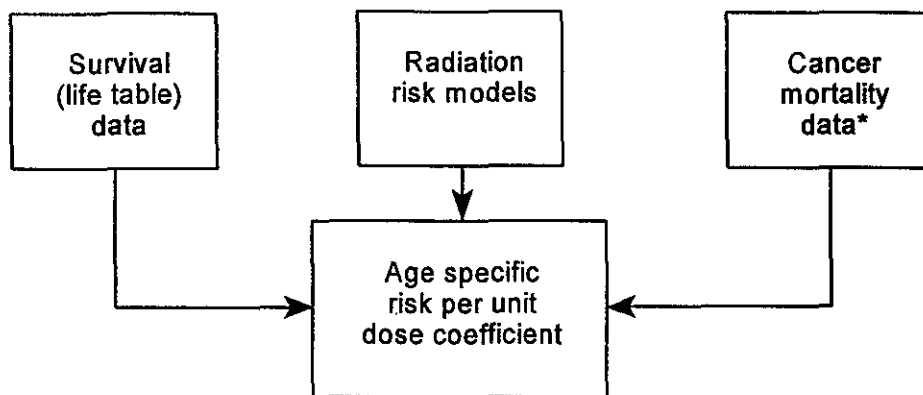

*Used for relative risk model calculations.

External exposure:

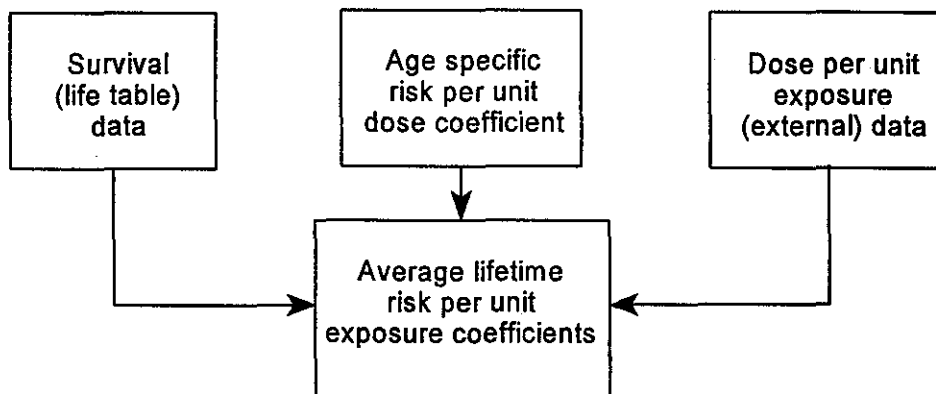

Internal exposure:

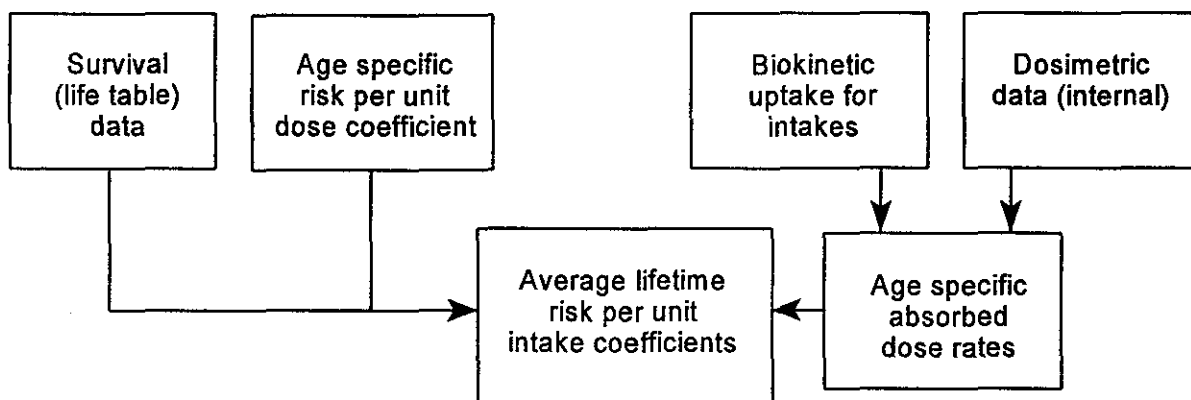

- Biokinetic and dosimetric models are used to estimate time-dependent dose rates in various organs and tissues of the body. The organ-specific dose rates may vary independently over time.
 - The RADRISK computer code (Du80) is used to estimate dose rates from ingestion or inhalation of radioactive materials. The dosimetric methods used in RADRISK are based primarily on models recommended by the International Commission on Radiological Protection (ICRP) in ICRP Publication 30 (ICRP79).
 - For external exposures to radionuclides in soil, dose estimates are calculated for each radionuclide using volume and surface dose factors derived using the DFSOIL computer code (Sj84). These dose factors account for photon energy flux attenuation and buildup in soil, assuming the radionuclide is uniformly distributed in a large volume of soil. This method involves approximations which can considerably overestimate dose rates to body organs, and resulting estimates of radiation risk, for small volumes of contamination (small areal extent and/or depth). [The external dose coefficients from Federal Guidance Report No. 12 (EPA93) are not yet incorporated in the radionuclide slope factors, but are expected to be incorporated in future revisions.]
- Lifetime risk of developing a radiation-induced cancer in a body organ or tissue is assumed to be directly related to the dose delivered to that organ or tissue across all ages. Each dose that is received and accumulated adds an incremental risk of developing cancer at that site at a later time. The average risk per unit intake/exposure for an average member of the exposed population can be calculated as the expected risk per lifetime exposure, at a constant exposure rate, to a unit intake/concentration of the radionuclide of concern.
 - EPA's radionuclide slope factors developed prior to 1994 were based primarily on radiation risk models recommended by the National Academy of Sciences (NAS) Committee on the Biological Effects of Ionizing Radiation (BEIR) in its BEIR III report (NAS80).
 - In 1994, EPA published revised risk models for radiogenic cancer risks (EPA94a) which are incorporated in the current slope factors. The revised methodology incorporates: revised risk models based primarily upon recommendations of the ICRP (ICRP91), NRC (Gi91), and NCRP (NCRP85); a revised dose and dose rate effectiveness factor (DDREF); and a revised relative biological effectiveness (RBE) value for alpha radiation.
- In order to estimate the attributable cancer risk in the population of interest, actuarial life expectancy statistics are used to predict depletion of the population over time as a result of death from causes other than radiation exposure. The probability of dying at any age from competing risks is calculated from the mortality rate at that age for all causes, as specified in actuarial life tables for the U.S. population. By not modifying the survival function for the additional risk due to radiation, an asymptotic risk per unit dose or exposure can be calculated. In a stationary population, the population age distribution function is proportional to the survival function at each age.
 - Survival data and vital statistics for calculation of the current radionuclide slope factors have been taken from the decennial U.S. population data for 1979-1981 (NCHS85, 84, 83, 82). Previously, EPA used life table data from the 1970 decennial U.S. population (NCHS75, 73) in the calculation of radionuclide slope factors. Under the revised methodology, EPA also has adopted a more robust method for integrating the vital statistics and risk models.

- For each radionuclide, the cumulative number of radiation-induced cancers accumulated over the lifetime of the exposed population is calculated by summing the attributable cancers at each cancer site projected in survivors of all ages within the reference population in each year following the beginning of exposure. The attributable cancer risk at each cancer site is computed for each age (0 to 110 y) as the product of the dose to that site (rad/y), the cancer risk per unit dose for that site (risk/rad), and the survival function value at that age (probability of survival to that age). This risk estimate represents the expectation value of individual risk as well as the average risk within the reference population.
- Finally, this estimate of the lifetime attributable cancer risk is normalized for the cumulative lifetime exposure to estimate the radionuclide slope factor. For ingestion and inhalation, the average lifetime attributable cancer risk is divided by the cumulative lifetime activity intake of the exposed population, to obtain a slope factor for that radionuclide. For exposures to gamma rays emanating from radionuclides in the soil, the lifetime attributable cancer risk is divided by the product of the concentration of the radionuclide in soil and the average lifetime of a member of the exposed population to obtain a slope factor. In either case, the denominator represents the cumulative lifetime exposure an average individual in the reference population.

The following sections address each of these components of the analysis in more detail. Example calculations of the slope factor derivation for each exposure pathway are presented in Chapter 4.

2.2 EXPOSURE ASSUMPTIONS

For ingestion and inhalation, a constant activity intake rate (pCi/y) of a radionuclide is assumed. For the external exposure pathway, a constant radionuclide concentration in soil is assumed, which yields a constant dose rate in each body organ considered. The assumed rate of intake and concentration of radioactivity in soil are each arbitrary at this point, because the radionuclide slope factor is obtained, in part, by dividing by the total activity intake rate and duration, or by the total exposure duration in the case of external exposure. Although arbitrary, these exposure assumptions are needed in order to calculate time-dependent dose rates in body organs.

For ingestion and inhalation, additional important exposure assumptions include the chemical and physical form of the radionuclide or its carrier. Many radionuclides may exhibit different biokinetic behavior in the body depending upon the chemical and physical form—e.g., solubility and availability for absorption from the gastrointestinal tract may vary as a function of the chemical form of the ingested material, and clearance of inspired particulates from the lungs may vary as a function of both the physical dimensions of the inspired particulate and the chemical complex. The effect of the chemical and physical form on the dose estimates is further discussed in Section 2.2.2.1 and in Appendix A.

EPA has evaluated dose rates and cancer risks from appropriate chemical compounds of each radionuclide of concern. However, radionuclide slope factors are generally provided only for the most conservative forms (i.e., the assumptions yielding highest estimates of dose and risk) expected for environmental exposures. In cases where the measured chemical and physical forms of the radionuclides of concern in an actual exposure

situation differ from that assumed for the slope factors, this assumption may result in additional conservatism which should be considered in the uncertainty analysis in a site-specific risk assessment. [In certain cases where a radionuclide is present as an impurity rather than in a pure compound, use of the default parameters can sometimes lead to an underestimation of the risk.] For exposure situations where the default parameters may not be appropriate, users should contact the Remedial Guidance Section of ORIA at EPA-HQ.

2.3 RADIATION DOSIMETRY MODELS

Based upon the assumed exposure conditions, radiation dosimetry models are used to calculate doses to body organs. For each exposure pathway and radionuclide, the dose rates to body organs vary independently over time. The methods used for estimating dose rates to organs of interest is briefly summarized in the following sections. Additional details are provided in Appendix A.

2.3.1 Internal Exposure - Overview of Internal Dosimetry Models

The RADRISK computer code (Du80) is used to estimate dose rates from ingestion or inhalation of radioactive materials. The dosimetric methods used in RADRISK are based primarily on models recommended by the International Commission on Radiological Protection Publication 30 (ICRP79). The principal difference between RADRISK and the ICRP approach is that RADRISK computes estimates of absorbed dose rates to specified target organs separately for high and low linear energy transfer (LET) radiation, whereas ICRP Publication 30 considers committed dose equivalent to specified target organs. The time-dependent dose rates are needed for the life-table calculations discussed in Section 2.2.4. Detailed discussion of the technical basis and calculational methods used in RADRISK is provided elsewhere (Du80), and is only briefly summarized here.

All calculations performed with RADRISK assume that the parent radionuclide of a possible chain of radionuclides is taken into the body by inhalation or ingestion without any radioactive decay products. Intake of radioactive daughters must be treated in a separate execution of the code. However, the ingrowth and dynamics of daughters in the body after intake of the parent radionuclide are considered explicitly in the calculation of dose rate. In addition, consideration is made for different metabolic properties of the various radionuclides in the decay chain; this is another difference between the dose rate calculations conducted by EPA using RADRISK and those of the ICRP (ICRP79), in that the ICRP calculations assume that all radioactive decay products adopt the metabolic characteristics of the parent radionuclide. Exceptions are made for lead-210 and radium-228, where EPA has adjusted the models so the predicted activity distribution conforms more closely to other published data (see Appendix C). For most other radionuclides, the impact of these different assumptions is minor.

RADRISK considers intake of a given radionuclide by inhalation or ingestion. Inhaled activity is assumed to be originally deposited in the lungs; from the lungs, activity may be absorbed by the bloodstream or

mechanically cleared to the stomach. The model used in RADRISK for particulate deposition and retention in the respiratory tract is based on the ICRP Task Group Lung Model (ICRP66), and considers four major regions: the naso-pharyngeal, tracheobronchial, pulmonary, and lymphatic tissues. A fraction of the inhaled activity is initially deposited in each of the naso-pharyngeal, tracheobronchial, and pulmonary regions. Deposition and clearance of inhaled particulates in the lung are controlled by the physical size distribution of the particulates and their solubility classification. The size distribution of the particulate is specified by the activity median aerodynamic diameter (AMAD); an AMAD of 1 micron is assumed for all particulates in deriving the radionuclide slope factors. The model employs three clearance classes, based on the chemical properties of the element: classes D, W, and Y correspond to rapid (days), intermediate (weeks), and slow (years) clearance, respectively, of material deposited in the respiratory passages. Special cases, where these standard clearance classes are not used, include tritium vapor and noble gases.

Ingested activity is initially deposited in the stomach. It then is assumed to proceed sequentially through the small intestine, upper large intestine, and lower large intestine; activity may be absorbed into the bloodstream from any of the four segments of the gastrointestinal (GI) tract. The transfer rate of activity from one segment to the next is assumed to be proportional to the activity in the segment, such that the initial activity in a segment would decrease exponentially with time. While the model allows consideration of absorption from any combination of the four segments, only activity absorbed from the small intestine is normally assumed; the fractional absorption from the small intestine is traditionally denoted as f_1 .

Activity absorbed by the blood from the gastrointestinal or respiratory tract is assumed to be distributed among systemic organs and tissues or excreted, as specified by fractional uptake, distribution, and excretion coefficients. The list of organs and tissues in which activity is explicitly distributed (source organs) is element-dependent, and may include such organs as bone or liver where sufficient metabolic data are available. This list is complemented by an additional source region denoted as "OTHER", which accounts for that systemic activity not distributed among the explicit source organs and tissues or excreted; uniform distribution of this remaining activity within OTHER is assumed.

Radioactive material which enters an organ or tissue may be removed by both radioactive decay and biological removal processes. For each source organ or tissue, the fraction of the initial activity remaining at any time after intake is described by a retention function consisting of one or more exponentially decaying terms. The metabolic models used in RADRISK calculations are described elsewhere (Su81).

The time rate of change of activity in the body is modeled by a system of ordinary differential equations. The activity of a given radionuclide in an organ or tissue may be divided among several conceptual compartments. Each differential equation describes the rate of change of activity in a compartment. In each compartment, there may be formation of radioactive decay products, which may have different chemical and physical properties from those of the parent.

The estimates of activity in various organs, tissues, and compartments are used to estimate dose rates to specified organs of the body. Activity deposited in an organ or tissue may deliver a dose to that organ and, for penetrating radiations (i.e., gamma radiation and x-rays), to other organs and tissues of the body. While estimates of dose rate to an organ or tissue include contributions from activity distributed throughout the body (for penetrating radiations), activity within that organ or tissue generally contributes the principal component of dose. RADRISK calculates estimates of dose rate separately for low-LET and high-LET radiation, for subsequent use in estimating health risk. Additional details of this calculation are presented in Appendix A.

A revised set of mathematical models for estimating doses from internal radionuclide exposures, which provides more accurate estimates of dose rates to body organs and tissues from ingestion and inhalation exposures, is expected to be incorporated in future versions of the radionuclide slope factors. These revised dosimetric models and data incorporate organ/tissue-specific biokinetics and age-dependence, along with updated metabolic models and radionuclide decay data.

2.3.2 External Exposure - Overview of External Dosimetry Models

Radionuclide slope factors for external exposure are derived using external dose conversion factors computed by the DOSFACTER computer code (Ko81a, b, c). This code is used to estimate the dose rate in various organs and tissues, based on Monte Carlo simulations of the absorbed dose rate in each tissue for the spectrum of scattered photons in air resulting from a uniform concentration of monoenergetic photon sources. Dose rates are calculated for each radionuclide and organ of interest by taking the sum of the contributions from each photon energy associated with the radionuclide decay. Photons are assumed to emanate from soil uniformly contaminated with a given radionuclide throughout its extent, which was assumed to be infinite in depth and breadth (i.e., a uniform radionuclide concentration in a soil with infinite area and depth). External dose rate estimates for any given radionuclide do not include contributions from any radioactive decay products, and dose rates from all radioactive decay products must be explicitly considered to estimate the total dose and risk from the external exposure pathway.

Dose rates from external exposure to contaminated ground surfaces depend on the height of the receptor above the surface and the angle of incidence of photons on the body. This is especially important for low-energy photons, such as those that would reach the body after scattering in soil. The flux increases from the value for photons incident from immediately below the receptor to a maximum for photons arriving from close to the horizon. For the radionuclide slope factor calculations, a height of 1 meter above the ground is assumed. (The slope factor calculation does not depend strongly on the exact height assumed.) Attenuation and buildup due to scattering are considered in the calculations. Secondary scattering results in a distribution of photon energies at the receptor, which increases the radiation flux above that calculated on the basis of attenuation.

The current slope factors for external exposure represent the excess cancer incidence from exposure to a source of uniform activity per unit mass in soil (risk/y per pCi/g). However, the dose estimates on which these values

are based represent the dose rate to various organs and tissues of the body from exposure to a uniform radionuclide concentration on the ground surface (mrem/y per pCi/cm²). Consequently, conversion from a surface source to a volume source distribution is required. The ratio of the unit dose or risk factors for a volume concentration and for a surface concentration has the dimension of length and can be considered the effective depth of the radionuclide in soil relative to the surface dose factor.

Prior to 1992, the slope factors for external exposure were expressed as the cancer incidence from exposure to a source of uniform activity per unit surface area (risk/yr per pCi/cm²). Risk calculations using these slope factors presumed an effective depth of 10 cm for all radionuclides in soil. Since soil concentrations are typically expressed in units of activity per unit mass (pCi/g), risks were computed as the product of the surface slope factors, the assumed effective depth (10 cm), the assumed soil density (1.43 g/cm³), and the soil concentration. This effective depth value was expected to be reasonable for high-energy photon emitters, but was expected to overestimate the risk for low-energy photon (i.e., gamma and x-ray) emitters. In the latter case, it was expected that risk from internal exposures would be the predominant contributor to total risk, so the overestimate of external exposure risk would not be significant. In practice, however, this approach led to prediction of significant external exposure risks from radionuclides with low-energy photons, which were inconsistent with reasonable expectations.

A revised approach for estimating the effective depth was adopted by EPA in 1992 to alleviate this problem. The revised method uses volume and surface dose factors calculated with the DFSOIL computer code (Sj84), and computes the radionuclide-specific effective depth as the ratio of these values. Estimates of the effective depth using this approach range from over 5 cm for high-energy photon emitters to less than 0.05 cm for low-energy photon emitters. Dose and risk estimates computed using the previous method exceed the values computed with the revised method by factors ranging from less than 2 for some radionuclides with high-energy photons to several hundred for low-energy photon emitters. Additional discussion of the external dose model is provided in Appendix A.

The current estimates of dose and risk from external exposure to radionuclides in soil presume that the source is large in depth and areal extent. For small volumes of contamination (small areas and/or small depth), this method can considerably overestimate dose rates and resulting estimates of radiation risk. Correction factors to adjust for limited source areas are not currently considered in the slope factor derivation or application, but may be considered in the future.

Revised tabulations of external dose conversion factors have been published in Federal Guidance Report No. 12 (EPA93), based on revised scattering calculations and radionuclide decay data. The revised method provides more accurate estimates of dose rates to body organs and tissues from external exposure to contaminated ground surfaces and from submersion in contaminated air and immersion in contaminated water. Future revisions of the radionuclide slope factors are expected to incorporate these revised estimates.

2.4 CANCER RISK MODELS

The estimated dose rates for each organ or tissue at specified times following the beginning of exposure are used to estimate the number of incremental cancers in the exposed population attributable to the radiation exposure. The incremental risk of radiation-induced cancer in a given organ or tissue is estimated from the absorbed dose to the organ or tissue together with appropriate radiation risk factors for that organ or tissue.

The radiogenic cancer risk coefficients are often presented in terms of the probability of cancer expressed over a lifetime in an exposed individual per unit of dose (lifetime attributable cancer risk per rad). 'Expression' of a cancer means that the cancer becomes observable—i.e., the risk of developing cancer is estimated from analyses of cancers that have been observed, sometimes decades after the radiation exposure that caused the cancer. Often, the risk factors are expressed in terms of incremental cancer risk per collective dose (e.g., cancer cases per million person-rad), which more clearly expresses the fact that at very low levels of individual exposure it is impossible to know exactly where or when a radiation-induced cancer will appear in an exposed population, or if a radiation-induced cancer will appear in any particular individual. It can only be estimated that a certain number of cancers are likely to appear somewhere, at some time, in the survivors of an irradiated group.

For the purposes of risk assessment, cancers are considered to occur randomly within an exposed population. It is assumed implicitly that only one radiation-induced cancer occurs per person. For purposes of developing slope factors, it is also assumed that fatalities resulting from the radiation-induced cancers do not appreciably change the survival characteristics of the exposed population.

EPA's radionuclide slope factors prior to 1994 were based primarily on radiation risk models developed by the U.S. National Academy of Sciences (NAS) Committee on the Biological Effects of Ionizing Radiation, in its BEIR III report (NAS80); however, these risk estimates also incorporated elements of observations and models of the National Council on Radiation Protection and Measurements (NCRP), the United Nations Scientific Committee on the Effects of Atomic Radiation (UNSCEAR), the International Commission on Radiological Protection (ICRP), the National Cancer Institute, and the Radiation Effects Research Foundation (RERF, formerly named the Atomic Bomb Casualty Commission).

In 1994, EPA adopted a revised methodology to estimate radiogenic cancer risk for use in development of the radionuclide slope factors (EPA94a). The revised methodology reflects recent information pertaining to the Japanese atomic bomb survivors. For most cancer sites, the risk model adopted by EPA is one in which age-specific relative risk coefficients are obtained by taking a geometric mean of coefficients derived from the atomic bomb survivor data, employing two different methods for transporting risks from the Japanese to U.S. populations. These risk models have been used to estimate incremental cancer risks to specific organs and tissues per unit dose, based on age-at-exposure and vital statistics of the 1979-1981 U.S. population.

EPA's risk models address both cancer incidence and cancer mortality from radiation exposures, but radionuclide slope factors are based on cancer incidence risk models only (i.e., fatal + nonfatal cancers), to maintain consistency with the slope factors for chemical carcinogens. Both the original and revised EPA risk models address the expected expression rates of solid tumors, bone cancer, and leukemia. The cancer sites considered by EPA under the two risk methods are shown in Table 2-1. For use in the development of radionuclide slope factors, these organ-specific risk factors are further broken down as appropriate for specific age groups to consider age-dependent risk; examples of this application are presented in Chapter 4 and tabulations of the age-specific risk coefficients for each cancer site considered are presented in Appendix B.

**Table 2-1. EPA Organ-Specific Risk Estimates for Low-LET Radiation:
Low Dose, Low Dose Rate (lifetime attributable cancer risk per 10^6 rad [10^4 Gy])**

Cancer Site	Mortality		Incidence	
	NESHAPs	Revised ^a	NESHAPs	Revised ^a
Esophagus	9.1	9.0	9.1	9.5
Stomach	46.0	44.4	60.1	49.3
Colon	22.9	98.2	42.9	178.5
Liver	49.6	15.0	49.6	15.8
Lung	70.1	71.6	74.5	75.4
Bone	2.5	0.9	2.5	1.3
Skin	--	1.0	--	1.0
Breast	55.4	46.2	142.0	92.5
Ovary	--	16.6	--	23.8
Bladder	11.8	24.9	21.4	49.7
Kidney	5.9	5.5	21.4	8.4
Thyroid	6.4	3.2	64.3	32.1
Leukemia	44.8	49.6	44.8	50.1
Remainder	19.3	123.1	33.6	173.4
TOTAL	392.1	509.1	623.0	760.6

^a Dose and Dose Rate Effectiveness Factor (DDREF) is 1 for breast and 2 for all other sites. These risk coefficients are applicable to doses less than 20 rad (200 mGy) and for total doses greater than 20 rad from dose rates less than 10 mrad/min (0.1 mGy/min). The revised model incidence estimate for skin shown is for fatalities only; the entire incidence risk for skin would be about 500 times greater. The thyroid incidence risk includes only malignant neoplasms and does not include benign tumors or nodules. For high-LET radiation, risk estimates are increased by a factor of 20 (RBE=20) for all cancers except leukemia (RBE=1) and breast (RBE=10).

Different risk factors are used for low-LET radiation (beta and gamma radiations) and for high-LET radiation (e.g., alpha particles), to reflect differences in the ability of these different types of radiation to induce cancers. In the development of radionuclide slope factors prior to 1994, a relative biological effectiveness (RBE) of 8 was used in calculating the risk from a given absorbed dose of alpha particle irradiation for all cancer sites—i.e., the risk factor for alpha-particle irradiation is increased by a factor of 8 relative to low-LET radiation; in 1992, the high-LET risk estimates for leukemia were modified, based on epidemiological data, to revise the alpha RBE from 8 to 1.117 for leukemia only. Under EPA's revised methodology, the RBE value for alpha particles has been increased to 20, which is consistent with recommendations of the ICRP (ICRP91); exceptions are made for leukemia, which is assigned an RBE of 1, and breast, which is assigned an RBE of 10.

Radiogenic cancer risk also may be a function of the magnitude of radiation dose and the dose rate at which it is delivered. In the revised methodology, EPA has assumed a dose and dose rate effectiveness factor (DDREF) of 2 (i.e., the risk per unit dose is reduced by a factor of 2 for low level radiation exposures) for all cancer sites except breast, for which a DDREF of 1 is assigned. In the development of radionuclide slope factors prior to 1994, a DDREF of 1 was assumed for all cancers.

Two basic types of risk projection models may be used to estimate excess risks attributable to radiation exposures. In 'relative risk' models the expression rate of radiation-induced cancers is assumed to be proportional to the rate at which cancers develop in the general population; since the baseline cancer rate for most sites increases at later ages, the expression rate of radiation-induced cancers is also presumed to increase. 'Absolute risk' models, on the other hand, are based on the assumption that the expression rate of radiation-induced cancers is proportional only to the radiation dose and is independent of the baseline cancer rate in the population.

In the current EPA methodology (EPA94a), absolute risk models are used to estimate radiogenic cancer risk for bone, skin, and thyroid. Relative risk models are used for all other cancer sites considered. Previously, EPA assumed absolute risk models for leukemia and bone cancer only, and relative risk models for all other cancer sites.

Additional discussion of the models and assumptions used by EPA for estimating radiogenic cancer risk is provided in Section 3. For detailed discussion of this topic, the reader should consult *Estimating Radiogenic Cancer Risks* (EPA94a).

2.5 REFERENCE POPULATION DATA: MORTALITY & SURVIVAL STATISTICS

An important feature of the slope factor methodology is the use of actuarial data (e.g., life tables or survival functions) to account for the time dependence of the radiation dose and risk and to allow for competing risks of death in the estimation of risk due to radiation exposure. A life table or survival function consists of data

describing the age-specific mortality rates from all causes of death for a given population. This information is derived from data obtained on actual mortality within a real population.

Survival data and vital statistics for calculation of the current radionuclide slope factors have been taken from the decennial U.S. population data for 1979-1981 (NCHS85, 84, 83, 82). Previously, EPA used life table data from the 1970 decennial U.S. population (NCHS75, 73) in the calculation of radionuclide slope factors. Risk estimates for a different population could be obtained by modifying the survival function to reflect the age and sex distribution and mortality rates of the particular population at risk.

The use of a life table or survival function in the study of risk due to low-level radiation exposure is important because of the time delay inherent in radiation risk. After a radiation dose is received, there is a minimum latency (or induction) period of several years before a cancer can be clinically observed. Following this minimum latency period, the probability of occurrence of a cancer during a given year is assumed to persist for a specified period, called the plateau period. The length of both the latency and plateau period depend upon the type of cancer. If the latent and plateau periods are known, the survival function can be used to estimate the number of individuals who will die from incremental radiation-induced cancers in the presence of competing risk. This information also can be used to estimate the total number of years of life lost to those dying of radiation-induced cancer, the average number of years of life lost per incremental mortality, and the decrease in the population's life expectancy.

For internal exposure pathways, it is assumed that each member of the hypothetical exposed population is exposed to a constant unit activity intake rate of each radionuclide of interest—e.g., each exposed individual inhales or ingests 1 pCi/y beginning at birth and continuing throughout his/her lifetime. For external exposure to contaminated ground surfaces, it is assumed that each member of the reference population is continuously standing on a ground surface with a constant unit soil concentration of the radionuclide of interest. Since the models used for estimating dose rate and risk are assumed to be linear, these results may be scaled to evaluate other exposure conditions.

Absorbed dose rates computed for specific ages¹ throughout the assumed lifespan of 0 to 110 years for a constant intake rate are interpolated using a cubic spline method to obtain values at any age. For a given cancer site, the incremental *mortality* risk as a function of age is calculated as the product of the dose rate at

¹The current library of absorbed dose rates for specific ages (times following the beginning of chronic exposure) is an artifact of EPA's earlier calculational methodology. For the original RADRISK calculations, the span from 0 to 110 years was divided into nine intervals, and the dose rates (rad/yr) at the midpoints of these intervals (i.e., 1, 3, 6, 12, 20, 30, 42, 56, and 87 years) to specified organs and tissues were calculated as estimates of the average annual dose during that interval. Dose rates at two additional times (50 and 70 years) were also calculated for other purposes. While the radiogenic cancer risk models and calculational methodology have been revised, the RADRISK library of absorbed dose rates is still used for internal dose pathways.

Figure 2-2. How are radionuclide slope factors derived?

- Step 1. Determine applicable exposure pathway: inhalation, ingestion, or external exposure.
- Step 2. Determine dose rate per unit exposure for the radionuclide to each organ/tissue of interest.
- Step 3. Determine incremental cancer risk per unit dose rate for each cancer site (risk factors).
- Step 4. Determine survival function for the reference population (probability of survival for an average member of the population at each age due to risks other than radiation exposure).
- Step 5. Calculate lifetime attributable cancer risk by summing the attributable cancers at each cancer site predicted in survivors of all ages within the reference population during each year of exposure [i.e., $\sum \text{Dose}_{s,a} (\text{rad}/\text{y}) \times \text{Risk}_{s,a} (\text{rad}^{-1}) \times \text{Survival}_a (\text{probability}) \times \text{Duration} (1 \text{ y})$ for each cancer site, s , and each age, a (0 to 110 y)].
- Step 6. Calculate radionuclide slope factor by dividing the lifetime attributable cancer risk by the cumulative lifetime exposure [nominally estimated as the product of the unit exposure rate and the average life expectancy for the reference population (e.g, 73.77 y for the 1980 U.S. population)].

that age and the corresponding mortality risk per unit dose of radiation at that age (see Tables B-2 through B-17), weighted by the probability of survival to that age (see Table 4-1).

This quantity is divided by the lethality fraction (see Table B-1), and integrated from age 0 to 110 to obtain the lifetime *incidence* risk at a constant intake (or exposure) rate. The estimates of the incidence risk for each cancer site are then summed over all cancer sites to obtain the total number of radiation-attributable cancers projected to develop during the lifetime of the exposed population.

The intake (or external exposure) rate is also integrated over the same interval to obtain the lifetime intake (or exposure). Finally, the slope factor (the average lifetime incidence risk per unit intake or exposure) is computed as the quotient of these two quantities—i.e., by dividing the lifetime attributable cancer risk by the cumulative lifetime exposure.

This procedure is performed for each radionuclide of interest and for each of the three modes of exposure (inhalation, ingestion, and external exposure), as appropriate (see Figure 2-2). Simplified example calculations are presented in Chapter 4. Additional discussion of the calculational methodology is presented in Appendix D.

Chapter 3

EPA Radiogenic Cancer Risk Models

Chapter 3 presents a summary of the radiogenic cancer risk models used in the development of the radionuclide slope factors. EPA's recently revised methodology for estimating radiogenic cancer risk is discussed here; similar information on previously recommended risk models is presented in Appendix C. More complete discussions of the two approaches are presented elsewhere (EPA94a for the recently adopted methodology, EPA89b for the previous methodology).

3.1 BACKGROUND

The principal adverse biological reactions associated with ionizing radiation exposures from radioactive substances in the environment are carcinogenicity, mutagenicity, and teratogenicity. Carcinogenicity is the ability to produce cancer. Mutagenicity is the property of being able to induce genetic mutation, which may be in the nucleus of either somatic (body) or germ (reproductive) cells. Teratogenicity refers to the ability of an agent to induce or increase the incidence of congenital malformations as a result of permanent structural or functional deviations produced during the growth and development of an embryo (these are more commonly referred to as birth defects). Radiation can induce other deleterious effects at acute doses above about 25 rad (0.25 Gy), but doses of this magnitude are not normally associated with radioactive contamination in the environment.

Ionizing radiation causes injury by breaking constituent body molecules into electrically charged fragments called "ions" and thereby produce chemical rearrangements that may lead to permanent cellular damage. Ionizing radiation can also damage DNA structure. The degree of biological damage caused by various types of radiation varies according to how close together the ionizations occur. Some ionizing radiations (e.g., alpha particles) produce intense regions of ionization. For this reason, they are called high-LET (linear energy transfer) particles. Other types of radiation, such as beta particles, are called low-LET radiations because of the sparse pattern of ionization they produce. High-energy photons (e.g., x-rays and gamma rays) are not charged particles and, strictly speaking, have no LET; however, their interactions with matter produce low-LET electrons, and therefore they are generally classified with low-LET particles. In equal doses, the carcinogenicity and mutagenicity of high-LET radiations are usually found to be roughly an order of magnitude greater than those of low-LET radiations.

For environmental exposures to radioactive materials, carcinogenic risk is considered to be limiting. Acute effects are observed only at very high doses. Radiation-induced genetic effects have not been observed in human populations, and extrapolation from animal data indicates that risks per unit exposure are smaller than the risk of cancer; moreover, these risks may be induced only during the reproductive years and expression of the genetic risk may be spread over many generations. The risk per unit exposure of serious teratogenic

effects may be greater than the risk of cancer; however, there is some indication of a threshold for teratogenic effects and these effects can be induced only during gestation. Therefore, for purposes of developing the radionuclide slope factors considered in this report, only carcinogenic effects are considered.

Whereas many, if not most, chemical carcinogens appear to be organ- or tissue-specific, ionizing radiation can be considered pancarcinogenic. According to Storer (St75): "Ionizing radiation in sufficiently high dosage acts as a complete carcinogen in that it serves as both initiator and promoter. Further, cancers can be induced in nearly any tissue or organ of man or experimental animals by the proper choice of radiation dose and exposure schedule." Radiation-induced cancers that have been reported in humans include those in the following tissues: thyroid, female breast, lung, bone marrow (leukemia), stomach, liver, large intestine, brain, salivary glands, bone, esophagus, small intestine, urinary bladder, pancreas, rectum, lymphatic tissues, skin, pharynx, uterus, ovary, mucosa of cranial sinuses, and kidney (UNSC77, 82; NAS72, 80, 90; Be77, Ka82, Wa83).

Studies of populations exposed to high levels of radiation have identified the organs at greatest risk following radiation exposure. The major sources of human epidemiological data include: the survivors of the atomic bomb explosions at Hiroshima and Nagasaki; a large group of patients who were given x-ray therapy for ankylosing spondylitis of the spine during the years 1934 to 1954; several groups of women who were exposed to x-rays during diagnostic radiation of the thorax or during radio-therapy for conditions involving the breast; several groups of patients who were medically treated with x-rays to alleviate some benign conditions; underground miners exposed to elevated levels of radon and its decay products; workers who ingested radium-226 and radium-228 while painting watch and clock dials; and patients injected with thorotrast (colloidal thorium dioxide) as an x-ray contrast medium.

In addition to this large body of human data, radiation-induced cancers also have been observed in many animal species, including rats, mice, hamsters, guinea pigs, cats, dogs, sheep, cattle, pigs, and monkeys. Induced through multiple routes of administration and at multiple dose levels, these cancers have occurred in numerous organs and tissues. These animal studies have provided information on the significance of dose rate compared with the age of the animals at exposure, the sex of the animals, and the genetic characteristics of the test strain. They have shown that radiation-induced cancers become detectable after varying latent periods, sometimes several years after exposure. The animal studies further show that the total number of cancers that eventually develop varies proportional to the dose each animal receives. Experimental studies in animals have also established that the carcinogenic effect of high-LET radiation (alpha radiations or neutrons) is greater than that of low-LET radiation (x-rays or gamma rays).

Not all of the cancers induced by radiation are fatal, and the lethality fraction may differ for different cancer sites. The BEIR committees and ICRP have estimated cancer lethality by site and sex (NAS80, ICRP91). Their estimates range from about 10 percent fatal in the case of thyroid cancer to 100 percent fatal in the case of liver cancer. On the average, females have about 2 times as many total cancers as fatal cancers following radiation exposure, and males have about 1.5 times as many.

In addition to the evidence that radiation is pancarcinogenic, and as such can induce cancers in many different sites, it also appears that it can induce cancer by any route of exposure (dermal, inhalation, ingestion, and injection). Exposure routes considered in the development of radionuclide slope factors include inhalation, ingestion, and external exposures.

3.2 CANCER RISK ESTIMATES FOR LOW-LET RADIATION

The most important source of epidemiological data on radiogenic cancer risks from low-LET radiation exposures is the population of survivors of the atomic bomb detonations in Hiroshima and Nagasaki, Japan. The atomic bomb survivors have been studied for more than 40 years in a carefully planned and monitored epidemiological survey (Ka82, Wa83). They are the largest group that has been studied, and they provide the most detailed information on the response pattern for organs, by age and sex, over a wide range of doses of low-LET radiation.

Nevertheless, there are gaps in the human data on radiation risks. For example, no clear-cut evidence of excess genetic effects has been found in irradiated human populations, perhaps due to the limited numbers in the exposed cohort providing inadequate power to detect a dose-response. Likewise, no statistically significant excess cancer risk has been demonstrated below about 10 to 20 rad (0.1 to 0.2 Gy), whereas the dose range of interest from the standpoint of environmental exposures is much lower. Since the epidemiological data are incomplete in many respects, risk assessors must rely on mathematical models to estimate the risk from exposures to low-level ionizing radiation. The choice of models, of necessity, involves subjective judgments but should be based on all relevant sources of data collected by both laboratory scientists and epidemiologists. Thus, radiation risk assessment is a process that continues to evolve as new scientific information becomes available.

3.2.1 Dose Response Function and Dependence on Dose Rate

Radiogenic cancers in humans have been observed, for the most part, only following doses of ionizing radiation that are relatively high compared to those likely to result from a combination of background radiation and environmental contamination. Therefore, a dose response model must be chosen to quantify the risks and to characterize their uncertainties for small incremental doses above natural background. The primary types of dose response models generally considered for radiogenic cancer risk include: (1) the linear model, in which the number of effects (risk) is directly proportional to dose at all doses; (2) the linear-quadratic model, in which risk is very nearly proportional to dose at very low doses and proportional to the square of the dose at high doses; and (3) the quadratic model, where the risk varies as the square of the dose at all dose levels.

A comprehensive examination of this question was contained in NCRP Report 64 (NCRP80). Based primarily on laboratory studies of cells, plants and animals, the report advocated a linear-quadratic dose response for acute doses up to about 250-400 rad (2.5-4 Gy), above which the dose response begins to turn over due to cell

killing effects. At low doses, the quadratic term is negligible in comparison to the linear term. The NCRP committee defined the low dose region as 0-20 rad (0-0.20 Gy). Evidence was also cited to the effect that the D^2 term in the dose response function vanishes when the radiation is delivered at low dose rates, even for total doses above 20 rad (0.2 Gy).

According to current theories of radiogenic cancer induction, the low-LET dose response should be linear at low doses or dose rates, and with equal slopes. At higher doses and dose rates, multiple track events become important, and the dose response should bend upward. In these circumstances, the response per unit dose at low doses and dose rates will be overestimated if one extrapolates linearly from observations made at high doses, acutely delivered (NCRP80). The degree of overestimation is commonly expressed in terms of a dose and dose rate effectiveness factor (DDREF)—e.g., a DDREF of 2 means the risk per unit dose observed at high acute doses should be divided by 2 before being applied to low dose and dose rate conditions.

NCRP has suggested DDREF values of 2 to 10 (NCRP80). These values are based on analysis of animal studies that showed reduced effects at low doses for a number of biological endpoints, including radiogenic cancer in animals, chiefly rodents. However, the data on humans seem to be somewhat at variance with the data from animal studies. Atomic bomb survivor data on solid tumors suggest a linear dose response relationship with no indication of a reduction in risk per unit dose at low doses. For leukemia, there is evidence of a curvilinear dose response relationship, suggestive of a DDREF of about 2. Clinical studies of radiation-induced breast and thyroid cancer have shown little or no reduction in risk with dose fractionation (NAS80, La80, Sh84, Da89, Ho92); this suggests a DDREF of 1 for these sites. Studies of tuberculosis patients who had undergone repeated fluoroscopic examinations found an elevated risk of breast cancer from fractionated doses of x-rays, but no indication of an excess lung cancer risk (Da89, Ho92); when compared with observed lung cancer risk in the atomic bomb survivors, the results of these studies suggest that the DDREF may be quite large for lung cancer induction, although the possibility of confounding by the underlying disease cannot be ruled out.

The results on human solid tumors appear to differ from those obtained through laboratory studies, including studies of radiation-induced tumorigenesis in mice and rats. For the most part, the laboratory studies suggest a DDREF of about 2 or 3, and sometimes higher, depending on the endpoint; on the other hand, most evidence on humans suggests a lower DDREF, possibly about 1 for most sites. There are also experimental data indicating that radiation-induced mutation may increase linearly with dose, and independently of dose rate, in human cells but not in rodent cells (Gr85).

Current mechanistic explanations for a DDREF all involve DNA repair. The linearity of the dose response at low doses suggests that DNA repair is maximal and independent of dose rate for doses below about 20 rad (0.2 Gy). Repair of radiation-induced DNA damage is found to be largely complete within a few hours of an acute exposure (Wh83, UI87). Consequently, protracting the dose beyond this time span should have little or

no effect on the risk of cancer induction. It is expected, therefore, that repair will be maximal so long as no doses above 20 rad (0.2 Gy) are delivered within a few hours.

While none of these examples is persuasive by itself, collectively they indicate that it may not be prudent to assume that all kinds of cancers are reduced at low dose rates and/or low doses. However, it may be overly conservative to estimate the risk of all cancers on the basis of the linearity observed for breast and thyroid cancer.

3.2.2 Risk Projection Models

None of the exposed populations have been observed long enough to assess the full effects of their exposures if, as currently thought, most radiogenic cancers occur throughout an exposed person's lifetime (NAS80, 90). Therefore, another major choice that must be made in assessing the lifetime cancer risk due to radiation is to select a risk projection model to estimate the risk for a longer period of time than currently available observational data will allow.

To estimate the risk of radiation exposure that is beyond the period of observation, either a relative risk or an absolute risk projection model (or suitable variations) may be used. The constant relative risk projection model projects the currently observed percentage increase in annual cancer risk per unit dose into future years, i.e., the increase is proportional to the underlying (baseline) risk. An absolute risk model projects the average annual number of excess cancers per unit dose into future years at risk, independent of the baseline risk.

Because the underlying risk of most types of cancer increases with age, the relative risk model predicts a larger probability of excess cancer toward the end of a person's lifetime. In contrast, the absolute risk model predicts a constant force of mortality across time. Therefore, given the incomplete data and less than lifetime follow-up, a relative risk model projects a somewhat greater total lifetime cancer risk than that estimated using an absolute risk model.

Recent evidence favors the relative risk projection model for most solid cancers. The epidemiological data for the atomic bomb survivors indicate that, for solid cancers, relative risks have continued to remain constant in recent years, while absolute risks have increased substantially (Ka82, NAS90). For cancers other than leukemia, there is strong evidence of an increasing risk with age at expression, roughly in proportion to the increase with age of baseline cancer mortality. The data are generally consistent with a constant relative risk model in which the risk coefficients decrease with age at exposure. There is some suggestive evidence of a fall-off in relative risk with time after exposure, especially for childhood exposures (NAS90, UNSC88), but further epidemiological surveillance will be necessary to clarify the pattern of temporal change (Sh88).

Smith and Doll (Sm78) reached similar conclusions on the trend in excess cancer with time among the irradiated spondylitic patients. More recent analysis of the spondylitic data does show evidence of a fall-off in relative risk after 25 years post-exposure, but the decrease is not yet statistically significant (Da86).

Although considerable weight should be given to the relative risk model for most solid cancers, the model does not necessarily give an accurate projection of lifetime risk. The mix of tumor types varies with age so that the relative frequency of some common radiogenic tumors, such as thyroid cancer, decreases for older ages. Land has pointed out that this may result in overestimates of the lifetime risks when they are based on a projection model using relative risks (La83). While this may turn out to be true for estimates of cancer incidence that include cancers less likely to be fatal, e.g., thyroid, it may not be very important in estimating the lifetime risk of fatal cancers, since the incidence of most of the common fatal cancers, e.g., breast and lung cancers, increases with age.

Leukemia and bone cancer are exceptions to the general validity of a lifetime expression period for radiogenic cancers. Most of the leukemia risk has apparently already been expressed in both the atomic bomb survivors and the spondylitics (Ka82, Sm78). Similarly, bone sarcoma from acute exposure appears to have a limited expression period (NAS80, Ma83). For these cancers, an absolute risk projection model with a limited expression period appears to be adequate for estimating lifetime risk (NAS80).

The relative and absolute risk models used by EPA are age-dependent; that is, the risk coefficient changes, depending on the age of the exposed persons. Observational data on how cancer risk resulting from radiation changes with age are sparse, particularly so in the case of childhood exposures. Nevertheless, the explicit consideration of the variation in radiosensitivity with age at exposure is a significant improvement in methodology. It is important to differentiate between age sensitivity at exposure and the age dependence of cancer expression. In general, people seem to be most sensitive to radiation when they are young. In contrast, most radiogenic cancers seem to occur late in life, much like cancers resulting from other causes.

3.2.3 EPA Assumptions for Estimating Radiogenic Cancer Risk from Low-LET Radiation

Prior to 1994, EPA's estimates of cancer risks from low-LET radiation were based largely on the National Academy of Sciences BEIR III report (NAS80). These estimates of radiation risk were based on a presumed linear dose response function. A relative risk model with a lifetime expression period was assigned for all cancer sites except for leukemia and bone cancer, where an absolute risk model with a 25-year expression period was used. These risk estimates were used in the development of radionuclide slope factors prior to 1994. This methodology is summarized in Appendix C.

More recently, important new data have become available, especially revised dosimetry and further epidemiological follow-up on the Japanese atomic bomb survivors. EPA has recently adopted a revised methodology for estimating radiogenic cancer risks (EPA94a) to incorporate this new information. In addition,

the revised approach utilizes more recent vital statistics for the 1980 U.S. population, in place of the 1970 U.S. vital statistics used previously. The revised methodology is summarized below.

Further epidemiological follow-up of the Japanese atomic bomb survivors since the publication of the BEIR III report (NAS80) has lent additional support to the relative risk projection model for solid tumors. The additional data provided by the follow-up reduces statistical uncertainties in the risk coefficients and fills in important gaps pertaining to some organ-specific risks, particularly with respect to childhood irradiation (Pr88).

Also subsequent to BEIR III, there has been a major reassessment of doses assigned to the atomic bomb survivors, the effect of which, in general, is to increase the estimates of risk from low-LET radiation calculated according to a particular model. The major differences between the dose estimates developed in 1965 (the tentative 1965 dose estimates, T65) and the revised (Dosimetry System 1986, DS86) dose estimates are: (1) the neutron dose in DS86 is decreased to 10 percent of its former value in Hiroshima and 30 percent in Nagasaki (as a result, neutrons now contribute relatively little to the estimated excess of cancers in the two cities); (2) the DS86 free-in-air gamma dose increases somewhat in Hiroshima but decreases in Nagasaki relative to T65; (3) transmission of gamma rays through wooden structures is decreased by about a factor of 2 in DS86; and (4) transmission of gamma rays through the body to internal organs is generally increased, partially nullifying the change associated with the decreased transmission through structures (Pr87, Sh87).

It appears that either a linear or linear-quadratic dose response is consistent with the survivor data, analyzed according to the DS86 dose estimates (Pr87). However, as noted above, linear and linear-quadratic best fits to the data differ only slightly in their predictions at low doses. It would also appear that the residual difference in risk per unit dose between Hiroshima and Nagasaki is no longer statistically significant under DS86 dosimetry (Sh87).

Risk estimates have been derived to reflect these new data in several recent reports (Sh88, 90; UNSC88; St88; NAS90; ICRP91; La91; Gi91). Based on a critical review of these studies and some ancillary information, EPA has developed a revised methodology for estimation of radiogenic cancer risk.

3.2.3.1 Risk Models. EPA has adopted risk models developed by Land and Sinclair (La91) for the ICRP (ICRP91) to develop nominal "best estimates" of radiogenic cancer risk to most organs of concern. For breast cancer, however, the model developed by Gilbert (Gi91) for the NRC has been adopted by EPA.

The ICRP approach reflects a well defined, predetermined procedure in which the excess cancer mortality observed in the atomic bomb survivors, by site, age, and sex, are used to calculate risk in the U.S. population, and include relatively detailed information on the dependence of risk for specific cancer sites on age at exposure. For the most part, the ICRP calculations make direct use of the age- and sex-specific relative risk coefficients presented in RERF Report 11 (Sh88, Table 5A). Information in the RERF report is also used to

incorporate three additional cancer sites into the model: esophagus, ovary, and bladder. Age-specific risk coefficients for "residual" cancers are obtained by subtraction of specified cancers from the total cancers expressed to date for the period of follow-up.

In the ICRP approach, three methods are used to transport risk estimates from the study population of atomic bomb survivors to the reference population of interest. The additive projection model involves a direct transport of age- and sex-specific absolute risk coefficients. The multiplicative projection model involves a direct transport of relative risk coefficients. The NIH projection model is a hybrid of the additive and multiplicative methods. For solid tumors, the total excess risk after the minimal latency period is projected for the period of epidemiological follow-up (i.e., 10-40 years for the RERF data) using the absolute risk coefficients of the additive model. However, it is considered to be distributed over time after exposure as a multiple of the baseline rate. The NIH model relative risk coefficient yields the same risk over the follow-up period as the absolute risk model. This coefficient is then used to project lifetime risk in the same way as for the multiplicative model. With the NIH method, the excess risk varies with age, in proportion to the baseline rates in the population of interest, but only weakly reflects differences between these baseline rates and those in Japan.

A peculiarity of the NIH projection model is that it can artificially introduce age-dependent variability where none can be discerned from the data. For example, in view of the very limited data on lung and colon cancer mortality among the atomic bomb survivors exposed as children, the authors have assigned equal risk coefficients for these cancers to the 0-9 year and 10-19 year age groups, for both the additive and multiplicative models (Sh90, La91). However, if these age groupings are maintained, the derived NIH projection model will contain significantly higher risk coefficients for the 0-9 year group, and a likely inflation of the risk estimates associated with childhood exposures. To avoid this problem, the NIH risk coefficients for lung and colon are calculated on the basis of treating the 0-19 year age group as a single group.

In developing organ-weighting factors, ICRP adopted an arithmetic average of the multiplicative and NIH model projections for each cancer site. Land and Sinclair (La91) note that the multiplicative but not the additive model provides a reasonable approximation to the epidemiological data; however, they also point out that little information is available pertaining to the transfer across populations.

The NRC approach more explicitly incorporates expert judgement in the selection of risk coefficients, although these coefficients do not generally represent statistical best estimates obtained from an analysis of epidemiological data. Age-specific, constant relative risk models are recommended for all sites except leukemia, bone, thyroid, and skin, for which absolute risk models are proposed. The models are designed to be as simple as possible, but to yield estimates of risk on an age- and organ-specific basis, which are reasonably central in view of the scientific uncertainties.

3.2.3.2 Organ Risk Estimates. In view of the uncertainty in transportation of risk estimates from Japan to the U.S. population, EPA has adopted a methodology in which most age- and site-specific risk coefficients are taken to be the geometric means of the corresponding coefficients from the ICRP multiplicative and NIH models; this method has been used to derive risk estimates for esophagus, stomach, colon, lung, ovary, bladder, leukemia, and residual cancers. The choice of the geometric mean reflects a judgement regarding the distribution of uncertainty associated with the transportation of risk, and is believed to provide a reasonable central estimate of the risk, by organ and by age at irradiation. While giving weight to both the multiplicative and NIH approaches, it tends to de-emphasize extreme values which may reflect large extrapolations based on a few excess cancers observed among those exposed as children. In calculation of the geometric mean risk estimates, EPA has also made adjustments for differences in the temporal assumptions in the multiplicative and NIH models for leukemia, and for apparent anomalies in the risk coefficients presented by Land and Sinclair for "residual" cancers in the 0-9 year age group.

For breast cancer, however, the model of Gilbert (Gi91) has been adopted by EPA. This model has the advantage of being derived from data for North American women. This breast cancer model was based largely on studies of women from the U.S. and Canada who received diagnostic or therapeutic doses of x-rays. This model thus avoids the major issue of transporting risk estimates from Japan to the U.S., where the baseline rates of breast cancer are much higher. Risk estimates using this model are in reasonable agreement with the ICRP NIH model but are substantially lower than the projection made with the ICRP multiplicative model. The model exhibits a sharp decrease in risk with age at exposure.

Estimates of kidney cancer risk are based upon the age- and sex-averaged excess relative risk coefficient from the Atomic Bomb Survivor Study and the corresponding absolute risk coefficient reported by Shimizu et al. (Sh88), adjusted from shielded kerma to absorbed dose. These risk coefficients are then used to estimate risks through the ICRP multiplicative and NIH projection models, and the geometric mean of these two estimates computed for use by EPA.

For liver cancer, EPA has adopted a constant relative risk model independent of age-at-exposure and sex. This model is used in conjunction with a risk coefficient derived using the BEIR III and BEIR IV estimates of fatal liver cancer induction by alpha particles (300 excess fatal liver cancers per million person-rad; 30,000 excess fatal liver cancers per million person-Gy) and an assumed RBE of 10 for alpha particles (relative to acute high-dose, high-dose-rate low-LET radiation).

As a basis for estimating radiation-induced bone sarcomas, EPA has adopted the BEIR IV risk estimate for alpha irradiation by radium-224 (NAS88), with adjustment to convert from average skeletal dose to endosteal dose by assuming a factor of 7.5 reduction in the risk estimate; this estimate is further adjusted using an assumed RBE of 10 to estimate low-LET risk, and an assumed lethality fraction of 70%. Following BEIR III (NAS80), a constant absolute risk model was selected for projecting risk, with an expression period extending from 2 to 27 years after exposure.

EPA's estimates of risk to the thyroid continue to be based on the recommendations of the NCRP (NCRP85). Both the ICRP and NRC have also adopted this approach. The estimated fatality risk is calculated as one-tenth the incidence risk. The estimated incidence and mortality risks are each reduced by a factor of 3 in the case of exposures to iodine-125, -129, and -131; however, this reduction includes the effect of lowered dose rate on the risk, and no additional DDREF should be used in the case of these radioiodine exposures.

Estimates of skin cancer risks are highly uncertain, but the mortality is known to be relatively low. For acute exposures, EPA has adopted the ICRP mortality risk estimate (2 excess fatal cancers per million person-rad; 200 excess fatal cancers per million person-Gy); however, in contrast to ICRP, EPA has adopted a DDREF of 2 for estimating skin cancer risk at low doses and dose rates. Due to the large uncertainty in available data, EPA will ordinarily exclude nonfatal radiogenic skin cancers from its estimates of risk.

The site-specific risk coefficients for individual age groups are summarized in Table 3-1. Absolute risk models are used for bone, skin, and thyroid cancers, whereas relative risk models are used for all other cancers.

3.2.3.3 Risk Estimates for Low-Level Radiation Exposures. For the revised estimates of radiogenic cancer risk, EPA has adopted a dose and dose rate effectiveness factor (DDREF) value of 2 as a reasonable best estimate. This value has recently been adopted by the ICRP (ICRP91), as well as by other organizations (Gi91, CIRRPC92), and is expected to be widely applied for purposes of risk assessment and radiation protection worldwide.

The DDREF is applied to all organ-specific risks except for the breast. There is epidemiological evidence that dose fractionation has little or no effect on risk to the breast (NAS88); moreover, the risk model adopted by EPA is based mainly on fluoroscopy studies in which the doses were in fact delivered as multiple small fractions (NAS90, Gi91). Hence, EPA has adopted a DDREF of 1 for breast cancer. This choice assumes that the risk (per unit dose) of highly fractionated exposures approximates the risk at low doses and dose rates.

EPA has defined specific conditions under which the DDREF should be applied (EPA94a). Although the biological mechanisms are not yet elucidated, according to current thinking: at low doses, repair is maximal, and the unrepaired DNA damage reflects single track events; at higher (acute) doses, repair decreases due to damage caused by multiple tracks passing through the cell nucleus in close temporal proximity. It would appear that repair efficiency is maximal for all doses below about 20 rad (0.2 Gy) (NCRP80). It also appears that DNA repair is essentially completed within a few hours after radiation-induced damage (Wh83, Ul87). Consequently, maximum repair efficiency should occur so long as the dose does not exceed 20 rad (0.2 Gy) over a few hours. In view of these considerations, EPA has adopted UNSCEAR's recommendation that the DDREF should be applied whenever the total dose is below 20 rad (0.2 Gy) or the dose rate is below 10 mrad/min (0.1 mGy/min) (UNSC93).

Table 3-1. Mortality risk coefficients for EPA revised risk methodology

Cancer Type	Risk Model Type	Age at Exposure					Lethality Fraction
		0-9	10-19	20-29	30-39	40+	
Male:							
Esophagus	R	0.2239	0.2312	0.2517	0.2892	0.3258	0.95
Stomach	R	1.2337	1.9165	0.19051	0.2881	0.2524	0.90
Colon	R	2.1565	2.1565	0.2809	0.4275	0.0899	0.55
Liver	R	1.3449	1.3449	1.3449	1.3449	1.3449	0.95
Lung	R	0.4060	0.4060	0.0453	0.1342	0.1794	0.95
Bone	A	0.0927	0.0927	0.0927	0.0927	0.0927	0.70
Skin	A	0.0672	0.0672	0.0672	0.0672	0.0672	--
Breast	R	0.0	0.0	0.0	0.0	0.0	--
Ovary	R	0.0	0.0	0.0	0.0	0.0	--
Bladder	R	1.2191	1.1609	1.0736	1.0544	0.9639	0.50
Kidney	R	0.3911	0.3911	0.3911	0.3911	0.3911	0.65
Thyroid	A	0.1667	0.1667	0.0833	0.0833	0.0833	0.10
Leukemia	R	672.16	244.07	323.47	228.86	142.51	0.99
Residual	R	0.7115	0.7140	0.1735	0.1754	0.1847	0.71
Female:							
Esophagus	R	1.0418	1.0896	1.2492	1.5831	2.0211	0.95
Stomach	R	3.4469	4.2721	4.0533	0.5797	0.4887	0.90
Colon	R	2.9680	2.9680	0.5755	0.8186	0.1870	0.55
Liver	R	1.3449	1.3449	1.3449	1.3449	1.3449	0.95
Lung	R	1.3753	1.3753	0.1921	0.5440	0.8048	0.95
Bone	A	0.0927	0.0927	0.0927	0.0927	0.0927	0.70
Skin	A	0.0672	0.0672	0.0672	0.0672	0.0672	--
Breast	R	0.7000	0.7000	0.3000	0.3000	0.1000	0.50
Ovary	R	1.3163	1.0382	0.8829	0.7678	0.6367	0.70
Bladder	R	1.0115	0.9296	1.0124	1.1032	0.9792	0.50
Kidney	R	0.3911	0.3911	0.3911	0.3911	0.3911	0.65
Thyroid	A	0.3333	0.3333	0.1667	0.1667	0.1667	0.10
Leukemia	R	761.07	225.81	281.76	153.12	154.28	0.99
Remainder	R	0.7119	0.7174	0.2932	0.2963	0.3031	0.71

Notes:

Risk model type Coefficient units
 Absolute (A) $10^{-6} \text{ (rad/y)}^{-1} [10^{-4} \text{ (Gy/y)}^{-1}]$
 Relative (R) $10^{-2} \text{ rad}^{-1} \text{ (Gy}^{-1})$

Lethality fractions (mortality:incidence ratios) are from Table B-19 of ICRP Publication 60 (ICRP91) except for remainder and skin; lethality fraction for remainder is calculated from the corresponding value of (2-k) in Table B-20 of ICRP Publication 60; for skin, only fatal cases are considered in the risk coefficients, and the much larger number of nonfatal cases, most of which are easily treated, are omitted.

Based on the risk models discussed above and the DDREF value of 2, EPA has developed risk estimates for excess cancer mortality risk resulting from exposure to radiation in low doses and dose rates for specific cancer sites listed in Table 3-2. To obtain estimates of radiation-induced cancer incidence, each site-specific

mortality risk estimate is divided by its respective lethality fraction, i.e., the fraction of radiogenic cancers at that site which are fatal. With the exception of thyroid cancer, the lethality fraction is generally assumed to be the same for radiogenic cancers as for the total cancers at that site. Site-specific cancer incidence risk is calculated using ICRP's recommended lethality fractions (ICRP91), with the exception of skin. For skin cancer, in the absence of data on what fraction of radiogenic skin cancer cases might be regarded as serious, the incidence estimate reflects only fatal cases and omits the much larger number of nonfatal cases, most of which are easily treated (see EPA94a). The site-specific estimates of radiogenic cancer mortality and incidence risk are summarized in Table 3-2.

Table 3-2. EPA revised radiogenic cancer risk coefficients - low dose and low dose rate [per 10⁶ rad (per 10⁴ Gy)]^a

Cancer Site	Mortality	Incidence	Lethality Fraction ^b
Esophagus	9.0	9.5	0.95
Stomach	44.4	49.3	0.90
Colon	98.2	178.5	0.55
Liver	15.0	15.8	0.95
Lung	71.6	75.4	0.95
Bone	0.9	1.3	0.70
Skin	1.0	1.0	--
Breast	46.2	92.5	0.50
Ovary	16.6	23.8	0.70
Bladder	24.9	49.7	0.50
Kidney	5.5	8.4	0.65
Thyroid	3.2	32.1	0.10
Leukemia	49.6	50.1	0.99
Remainder	123.1	173.4	0.71
Total	509.1	760.6	--

^a The Dose and Dose Rate Effectiveness Factor (DDREF) is 1 for breast and 2 for all other sites. These risk coefficients are applicable to doses less than 20 rad (0.2 Gy) and for total doses greater than 20 rad (0.2 Gy) from dose rates less than 10 mrad/minute (0.1 mGy/minute). The incidence estimate for skin is for fatalities only; the entire incidence risk for skin would be 500 times higher. The thyroid incidence risk includes only malignant neoplasms and does not include benign tumors or nodules.

^b Lethality fractions (mortality:incidence ratios) except for remainder and skin are from Table B-19 of ICRP Publication 60 (ICRP91); lethality fraction for remainder is calculated from the corresponding value of (2-k) in Table B-20 of the same document. For skin, the incidence estimate considers only fatal cases and omits the much larger number of nonfatal cases, most of which are easily treated.

For low-LET radiation, EPA's current estimate of the lifetime fatal cancer risk associated with uniform, whole-body irradiation of the U.S. population has increased by 24% compared to the previous estimate, from 392 to 509 excess fatal cancers per 10^6 person-rad (per 10^4 person-Gy). It is estimated that about 70% of all cancers induced by whole-body irradiation are fatal (nonfatal skin cancers excluded), corresponding to an incidence risk estimate of 761 excess cancers per 10^6 person-rad (per 10^4 person-Gy). These increases occur despite the change from a DDREF of 1 in the previous methodology (EPA89b) to a value of 2 in the revised methodology; without this change, the risk estimates would have more than doubled.

For occupational exposures (assuming a constant exposure rate between ages 18 to 65), the mortality and incidence risk estimates are 394 per 10^6 person-rad (per 10^4 person-Gy) and 567 per 10^6 person-rad (per 10^4 person-Gy), respectively.

3.2.3.4 Revised Life Table Analysis. In addition to the revised risk estimates noted above for specific cancer sites, EPA also updated the vital statistics and adopted a revised approach for integrating the risk model and vital statistics for the reference population. Male and female survival data (up to an age of 110 years) for the U.S. population during 1979-1981 (NCHS85), have replaced the corresponding data for the 1970 decennial U.S. population used previously. These data were used to calculate a combined life table for a male:female live birth ratio of 1.051.

The vital statistics are discrete data, typically tabulated at one or five year intervals. Radiogenic risk models used here are defined for several different age intervals and are inherently discontinuous. Previously, such risk model calculations were implemented by adapting actuarial methods developed for life table calculations, using the CAIRD computer code (Co78, Bu81). The revised method is to fit a cubic spline to discrete data and then to calculate interpolated values, derivatives, and integrals directly from the spline coefficients. This method admits almost any form of risk model and eliminates most of the ad hoc approaches that were necessary with CAIRD.

3.3 CANCER RISK FROM HIGH-LET RADIATION

Radiobiological data indicate that high-LET alpha radiation has a larger biological effect than an equal absorbed dose of low-LET radiation (NAS88, NCRP90, ICRP91). Unlike exposures to x-rays and gamma rays where the resultant charged particle flux results in linear energy transfers (LET) of the order of 0.2 to 2 keV per μm in tissue, 5-MeV alpha particles result in energy deposition of more than 100 keV per μm . The radiobiological results, including those for tumor induction, are generally suggestive of a linear non-threshold dose response for high-LET radiation, except for a possible fall-off in effectiveness at high doses. In contrast to low-LET radiation, the effects of high-LET radiation may increase with fractionation or with a decrease in dose rate.

A number of cohorts exposed occupationally or medically to internally deposited alpha emitters have shown an excess of cancer at heavily irradiated sites. Most important is the observed induction of: (1) lung cancer in miners inhaling radon progeny; (2) bone sarcomas in patients injected with radium-224; (3) bone sarcomas and head carcinomas in dial painters ingesting mixtures of radium-226 and radium-228; and (4) liver cancers in patients injected with Thorotrast, an x-ray contrast medium containing isotopes of thorium. Although other organs of the body received doses of alpha radiation in these populations, significant numbers of excess cancers were generally not observed at sites other than those mentioned. As a result, only upper bounds to the risk for these other organs can be estimated from studies of humans exposed to alpha irradiation.

Site specific cancer risk estimates for high-LET radiation (neutrons or alpha particles) are often calculated utilizing human epidemiological data on low-LET radiation (e.g., from the Atomic Bomb Survivor Study) and laboratory data on the relative biological effectiveness (RBE) of the high-LET radiation compared to a reference low-LET radiation (NCRP90). Since the dose response relationship obtained for low-LET radiation is typically linear or concave upward while that for high-LET radiation is linear or concave downward, the RBE is dose dependent. EPA is primarily concerned with risks at low doses and dose rates, where the acute high dose risk for low-LET radiation is reduced by the DDREF. Under these conditions, the dose responses for both low and high LET radiations are thought to be linear, and the RBE takes on a constant (maximum) value: RBE_M .

Ranges of estimated values for neutron and alpha particle RBE_M are wide, depending on both the biological system and the observed end-point; the uncertainty in the RBE_M estimate from an individual study is also usually large, primarily due to the uncertainty in extrapolation of low-LET data to low doses. The effectiveness of alpha emitters has been found to be 15 to 50 times that of beta emitters for the induction of bone sarcomas, liver chromosome aberrations, and lung cancers (NCRP90). Since the LET of secondary protons produced by fission neutrons in living tissue is comparable to that for alpha particles, data on the RBEs of fission neutrons provides ancillary information relevant to the estimation of alpha particle RBE. Where the dose response data on carcinogenic end-points are adequate to derive an estimate, fission neutrons have been found to have an RBE_M between 6 and 60 times that of low dose gamma rays (NCRP90).

3.3.1 Relative Biological Effectiveness

The ICRP (ICRP91) assumes that alpha radiation produces 20 times the risk, per unit absorbed dose, as low-LET radiation. This relationship is meant to hold in the limit of low doses and dose rates. Thus, it already takes into account the assumed DDREF of 2 for low-LET radiation; at high acute doses, the RBE would be 10. This must be kept in mind both when calculating alpha particle risks using models derived from low-LET epidemiological data and when estimating low-LET risks (for bone and liver) based on high-LET studies. Current NRC (Gi91) and NRPB (St88) recommendations also assume that at low doses the risk per unit absorbed dose from alpha particles is 20 times that from gamma rays.

The ICRP originally adopted the RBE value of 20 for alpha radiation in ICRP Publication 26 (ICRP77); prior to that time, ICRP had assumed a RBE for alpha particle irradiation of 10, i.e., the biological effect from a given absorbed dose of alpha particles was estimated to be 10 times that from an absorbed dose of low-LET x-rays or gamma rays of the same magnitude. The ICRP decision to increase the RBE to 20 followed from its decision to estimate the risk of low-LET radiations, in occupational situations, on the assumption that biological effects were reduced at low doses and dose rates. There is evidence that the risks from high-LET radiation are linear with dose and independent of dose rate (for low to moderate doses). Implicit in ICRP's risk estimates for low dose/dose rate gamma radiation is a dose rate reduction factor of about 2.5. The EPA (linear) risk model for low-LET radiation used prior to 1994 did not employ a DDREF (i.e., assumed DDREF=1); therefore, in order to avoid an artifactual inflation in high-LET risk estimates, EPA assumed a RBE of 8 (20/2.5) for calculating the risks from alpha particles. [The alpha RBE used in EPA's risk estimates for leukemia was revised from 8 to 1.117 in 1992, based on epidemiological data (see Appendix C).]

However, in EPA's revised methodology, a DDREF of 2 has been adopted whenever the total dose is below 20 rad (0.2 Gy) or the dose rate is below 10 mrad/min (0.1 mGy/min) for all cancer sites except breast, for which a DDREF of 1 is assigned. The revised methodology also adopts the ICRP recommendation for a RBE of 20 for alpha particles in this low dose and dose rate range. For higher doses or dose rates, however, EPA assumes a value of 10 for the alpha particle RBE. An exception is made for leukemia, for which a RBE value of 1 is adopted, consistent with available high-LET epidemiological data (NAS88, EPA91c), and for breast, for which a RBE of 10 is assigned. Risk estimates for radon decay products are also based directly on epidemiological data, rather than on dose estimates and associated RBE values.

3.3.2 Dose Response Function

In the case of high-LET radiation, a linear dose response is commonly observed in both human and animal studies. This response is not reduced at low dose rates (NCRP80). Some data on human lung cancer indicate that the carcinogenic response per unit dose of alpha radiation is maximal at low doses (Ar81, Ho81, Wh83); in addition, some studies with animals show the same response (Ch81, UI82). However, at low doses, departures from linearity are small compared to the uncertainty in the human epidemiological data, and EPA believes a linear response provides an adequate model for evaluating risks in the general environment.

3.3.3 Estimates of Cancer Risk from Alpha-Particle Emitters

With the exception of radiation-induced breast cancer and leukemia, EPA has followed the ICRP recommendation (ICRP91) in assuming an RBE for alpha particles of 20, in comparison to low-LET radiation at low doses and dose rates [i.e., for total doses of low-LET radiation below 20 rad (0.2 Gy) or dose rates below 10 mrad/min (0.1 mGy/min)]. Where the comparison is made against acute high doses of low-LET radiation, however, EPA assumes a value of 10 for the alpha particle RBE for these cancer sites. Thus the low-LET radiation DDREF of 2 now used by EPA for these cancers is implicitly incorporated into the RBE value

for alpha radiation. For breast cancer induction, a DDREF of 1 has been adopted. Therefore, the RBE will be independent of dose and dose rate. Since there is no DDREF correction of the low-LET breast cancer risk estimates at low doses and dose rates, it is assumed that the acute high dose RBE of 10 is also applicable to breast cancer at low doses and dose rates.

There is evidence that alpha particle leukemia risks estimated on the basis of an RBE of 20 are too high (EPA91). For this reason, EPA has adopted an alpha particle leukemia risk estimate of $5.0 \times 10^{-5} \text{ rad}^{-1}$ ($5 \times 10^{-3} \text{ Gy}^{-1}$), consistent with the available high-LET epidemiological data (NAS88, EPA91c). Quantitatively, this would correspond to an RBE of 1 for this site (relative to low dose, low-LET radiation). This is not to imply that alpha radiation is no more carcinogenic than low-LET radiation in inducing leukemia. At least in part, the lower than expected leukemia risk produced by alpha emitters may result from a nonuniform distribution of dose within the bone marrow (i.e., average doses to sensitive target cells may be substantially lower than calculated average marrow doses). Thus the RBE of 1 should be regarded as an "effective RBE," that reflects factors other than just the relative biological sensitivity to high- and low-LET radiations. Since the spatial distribution of the dose within the marrow will differ among alpha emitters, depending on the distribution of the radionuclide within bone and the energies of the emitted alpha particles, the effective RBE may be radionuclide dependent; however, this issue cannot be resolved with current data.

Estimates of the excess cancer mortality or incidence for specific cancer sites resulting from low doses and dose rates of high-LET radiation may be obtained by multiplying the low-LET cancer risk estimates presented in Table 3-2 (also see Appendix B) by the appropriate RBE value (1 for leukemia, 10 for breast, and 20 for all other cancer sites). For most cancer sites, the high-LET risk estimates have increased by more than the corresponding low-LET estimates, reflecting the change in RBE from 8 to 20, which comes from adopting a DDREF correction at low doses of low-LET radiation.

3.3.4 Estimates of Cancer Risk from Radon Decay Products

For estimating risks from radon decay products, EPA employs an epidemiological approach, based on human epidemiological data. When radon-222, a radioactive noble gas, decays, a number of short half-life radionuclides (principally polonium-218, lead-214, bismuth-214, and polonium-214) are formed. These decay products, commonly referred to as "progeny" or "daughters," readily attach to respirable aerosol particles in air. When inhaled, the radon progeny are deposited on the surfaces of the larger bronchi of the lung. Since two of these radionuclides decay by alpha-particle emission, the bronchial epithelium is irradiated by high-LET radiation. A wealth of data indicate that a range of exposures to the bronchial epithelium of underground miners causes an increase in bronchial lung cancer, both in smoking and in nonsmoking miners, and in some members of the general public. Recent reviews of radon risk data have been published by the NAS BEIR IV Committee (NAS88) and the ICRP (ICRP87).

The epidemiological approach to estimation of radon risks makes maximal use of the extensive human epidemiological data and avoids uncertainties associated with estimating the bronchial dose delivered by the inhaled radon progeny and selection of an appropriate RBE value. On this basis, EPA has adopted a central risk estimate for excess radon exposure of 2.2×10^{-4} fatal lung cancers per working level month (EPA92b, Pu92).

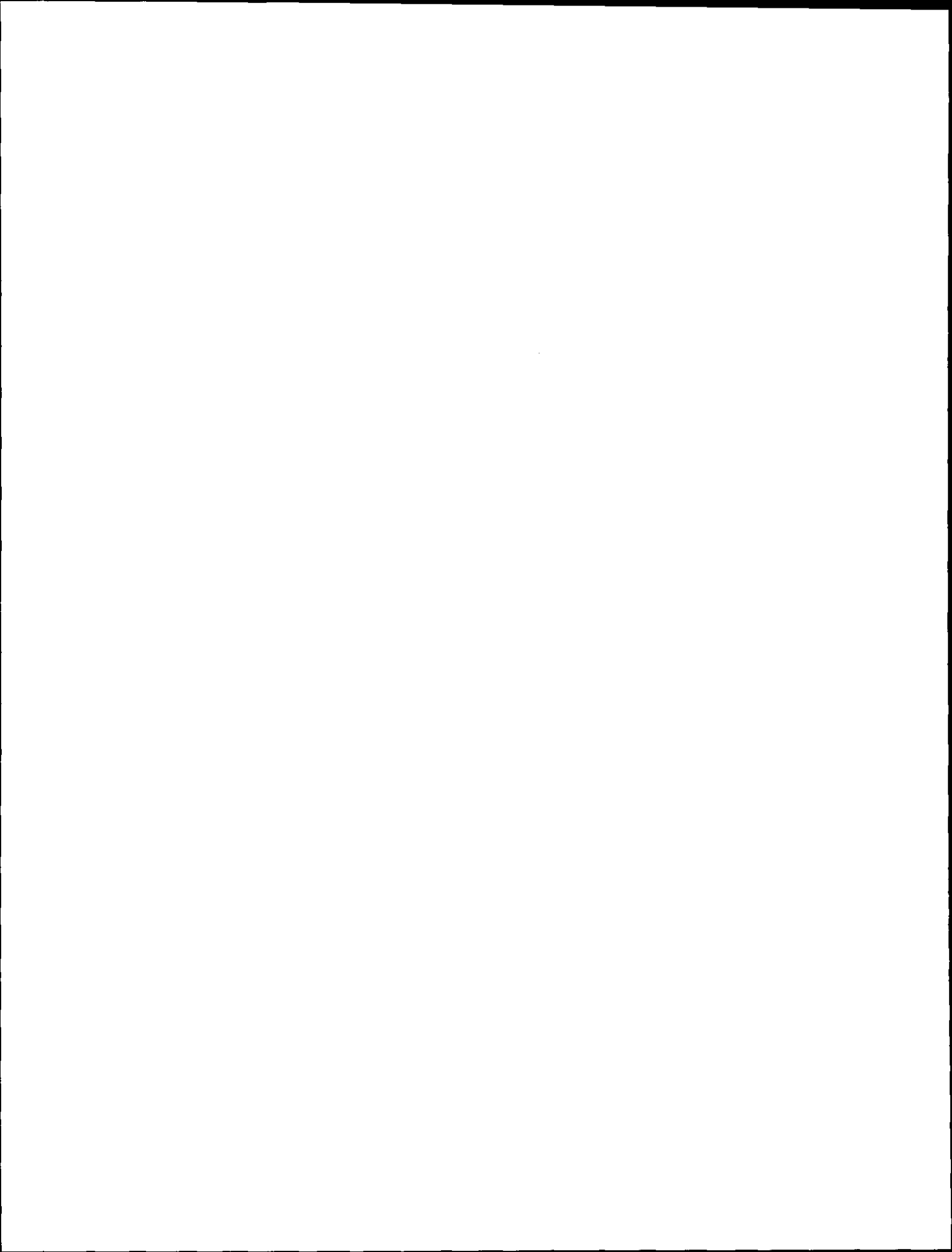

Chapter 4

Example Calculations of Radionuclide Slope Factors

Chapter 4 presents simple numerical examples of the method used to derive the radionuclide slope factors. As noted previously, the methodology used by EPA for derivation of the radionuclide slope factors was revised in 1994. Example calculations are presented here for the revised methodology only; similar example calculations for the previous methodology, used for development of the radionuclide slope factors prior to 1994, are presented in Appendix C.

4.1 BASIC CONSIDERATIONS

Radionuclide slope factors express the lifetime attributable cancer risk per unit exposure to a given radionuclide, where exposure is measured in units of activity intake (pCi or Bq) for inhalation and ingestion, or in units of soil concentration times exposure duration for external exposure [e.g., soil concentration (pCi/g or Bq/g) x time (y) = pCi-y/g or Bq-y/g]. The slope factor represents the total attributable cancer risk for all organs and cancer sites. In practice, the attributable cancer risk for each organ or cancer site is estimated separately based upon organ/tissue-specific dose rates and risk coefficients, and these estimates of risk to individual organs and tissues are summed to estimate total attributable risk. Dose rates to each organ or tissue may vary as a function of age and time after exposure, and the organ/tissue-specific risk coefficients may vary as a function of age and sex.

In the derivation of radionuclide slope factors, chronic exposure, at a constant exposure rate, is assumed for each radionuclide of concern. For chronic inhalation and ingestion exposures, dose rates to body organs and tissues may increase with time following the beginning of exposure, as a result of the accumulation of activity within the body. For the chronic external exposures, it is assumed that dose rates to each organ and tissue remain constant with time. In all cases, the lifetime attributable cancer risk accumulates with age. The methods used to estimate the dose rates to body organs and tissues of interest are summarized in Appendix A.

Since the radionuclide slope factors represent the attributable risk of cancer incidence, it is necessary to account for "competing" risks (i.e., risks from sources other than radiation exposure). As described previously, life tables and survival functions based on actuarial data are used to account for such competing risks, and to estimate the probability of survival and projected years of life remaining at various ages in a reference population. This estimate of the remaining years of life for the members of the exposed population at each age is considered to be the period available for expression of the radiogenic cancer risk. As discussed in the following sections, the methods used for implementation of the actuarial data in the slope factor calculations differ under EPA's recently revised and previous methodologies, but the concept remains the same.

Thus, for each age of exposure and for each cancer site considered, the attributable risk of cancer at that site due to the dose accumulated at that age from a given exposure pathway is based on the organ/tissue-specific absorbed dose rate in that year (rad/y or Gy/y), the organ/tissue-specific cancer risk per unit absorbed dose at that age (rad⁻¹ or Gy⁻¹), and the survival function (see Section 4.4) or reference life table data. The attributable cancer risk for each cancer site at each age is computed in this manner and summed to obtain the total number of radiogenic cancers of all types expected in the life of the exposed population. This total is then divided by the collective lifetime (person-years) of the exposed population and the lifetime activity intake rate to obtain a slope factor for ingestion and/or inhalation. An analogous procedure is used for external exposure, except the collective lifetime exposure is substituted for the lifetime intake. This estimate of attributable risk applies to an age-averaged member of the exposed population.

This procedure is followed for each radionuclide. For alpha-emitters, the risks due to the high-LET (alpha) radiation are calculated separately from those due to low-LET radiations (beta and gamma), and these are summed to obtain the slope factor for the radionuclide.

Three principal types of data are required for the slope factor calculations:

- Dose rates in each body organ or tissue of interest over the lifetime of the exposed population. Dose rates are calculated using the RADRISK code (Du80) for ingestion and inhalation assuming constant annual intake of activity, e.g., a constant intake rate of 1 pCi/y (0.037 Bq/y). For external exposure, the codes DFSOIL (Sj84) and DOSFACTER (Ko81c) are used to calculate the constant dose rates in body organs and tissues that result from gamma photons emitted by a radionuclide in soil in which the concentration of the radionuclide (pCi/g, Bq/g) is constant everywhere in the soil at all times considered, i.e., no radioactive decay or other removal processes are considered. Additional information on the methods and assumptions used to estimate dose rates is presented in Appendix A.
- Lifetime attributable cancer incidence risks per unit dose [e.g., expected cancer cases (risk) per 10⁶ rad or per 10⁴ Gy] for specific cancer sites and ages. As discussed previously, the risk estimates used by EPA for derivation of the radionuclide slope factors differ under the revised and previous methodologies; risk estimates used in EPA's previous methodology were based primarily upon the National Academy of Sciences BEIR III study (NAS80), whereas risk estimates under the revised methodology are based primarily upon ICRP recommendations (ICRP91).
- Actuarial statistics for the reference population to account for competing risks, and to estimate the projected years of life remaining at various ages in the reference population (i.e., the period available for expression of the radiogenic cancer risk). EPA's derivation of radionuclide slope factors prior to 1994 utilized actuarial statistics for the 1970 decennial U.S. population, and the life-table analysis was implemented using the CAIRD computer code (Co78). The revised methodology (EPA94a) utilizes vital statistics for the 1980 decennial U.S. population; these data are fit by a cubic spline function, from which interpolated values, derivatives, and integrals are calculated directly from the spline coefficients.

The use of these data to derive radionuclide slope factors is illustrated in the following sections.

4.2 REVISED METHODOLOGY FOR DERIVING EPA RADIONUCLIDE SLOPE FACTORS

4.2.1 General Information

In 1994, EPA developed a revised methodology for estimating radiogenic cancer risk and the derivation of radionuclide slope factors (EPA94a). The major changes include:

- Age- and sex-specific cancer incidence risk models (see Tables 3-1 and 3-2 and Appendix B) have been revised based upon the recommendations of the ICRP (ICRP91), NRC (Gi91), and NCRP (NCRP85). Absolute risk models are used for bone, skin, and thyroid cancer, whereas relative risk models are used for all other cancer sites (esophagus, stomach, colon, liver, lung, breast, ovary, bladder, kidney, leukemia, and remainder). Additionally, a dose and dose rate effectiveness factor (DDREF) of 2 has been adopted for low-LET radiation at low doses and dose rates typical of environmental exposures for all cancer sites except breast, for which a DDREF of 1 is assigned. (See Section 3 and EPA94a for additional discussion of the revised risk models.)
- Vital statistics used in the revised methodology have also been updated. Age- and sex-specific mortality data for the 1979-1981 U.S. population (NCHS85) have replaced the life table data for the 1970 population used previously. The survival function for the 1980 decennial U.S. life table data are shown in Table 4-1.
- In both the revised and previous methodologies, organ-specific dose rates over the lifetime of the exposed population were derived using: (1) the RADRISK computer code (Du80) for inhalation and ingestion exposures, assuming constant annual intake of activity; and (2) the DOSFACTER (Ko81c) and DFSOIL (Sj84) computer codes for external exposures to radionuclides in soil. However, it is anticipated that future revisions of the radionuclide slope factors will incorporate revised methods for estimating organ/tissue-specific dose rates. EPA has recently published revised dose rates for external exposure in Federal Guidance Report Number 12 (EPA93), and a revised methodology for estimating dose rates from internal exposures is currently under development. (See Appendix A for additional information on the methods and assumptions used to estimate dose rates.)

Integration of these data is complicated by the different time periods considered in each. The risk factors are for five age intervals: 0-9 y, 10-19 y, 20-34 y, 35-50 y, and 50+ y. RADRISK computes dose rates for the midpoints of nine time intervals following the beginning of exposure (times 1, 3, 6, 12, 20, 30, 42, 56, and 87 y). The survival function data are provided for each age in the population from 0 to 110 y. These data are integrated by averaging over the age intervals of the risk data, where the data are weighted by the survivors' collective person-years of life remaining at any age, or by the fraction of the time spent by survivors in the smaller age intervals. This is accomplished by fitting the discrete mortality data to a cubic spline function and then calculating interpolated values, derivatives and integrals directly from the spline function to estimate the attributable cancer risk and the projected years of life remaining at various ages in the reference population. Previously, these calculations were implemented by adapting actuarial methods developed for life table calculations, using the CAIRD computer program (Co78). The revised approach is much more flexible with respect to the form of risk models which may be used, and it eliminates most of the ad hoc approaches that

Table 4-1. Survival Function Based on 1980 Decennial Life Table Data (probability)

General Population				General Population				General Population			
Age	Population	Males	Females	Age	Population	Males	Females	Age	Population	Males	Females
0	1.0	1.0	1.0	38	9.5317E-01	9.3852E-01	9.6807E-01	76	5.4239E-01	4.3419E-01	6.4910E-01
1	9.8740E-01	9.8607E-01	9.8880E-01	39	9.5129E-01	9.3607E-01	9.6675E-01	77	5.1599E-01	4.0533E-01	6.2506E-01
2	9.8648E-01	9.8508E-01	9.8796E-01	40	9.4926E-01	9.3345E-01	9.6531E-01	78	4.8878E-01	3.7626E-01	5.9960E-01
3	9.8584E-01	9.8436E-01	9.8740E-01	41	9.4706E-01	9.3062E-01	9.6374E-01	79	4.6071E-01	3.4714E-01	5.7253E-01
4	9.8535E-01	9.8379E-01	9.8699E-01	42	9.4465E-01	9.2754E-01	9.6200E-01	80	4.3180E-01	3.1810E-01	5.4372E-01
5	9.8495E-01	9.8333E-01	9.8666E-01	43	9.4201E-01	9.2417E-01	9.6009E-01	81	4.0208E-01	2.8925E-01	5.1315E-01
6	9.8459E-01	9.8291E-01	9.8636E-01	44	9.3913E-01	9.2049E-01	9.5799E-01	82	3.7172E-01	2.6074E-01	4.8098E-01
7	9.8426E-01	9.8252E-01	9.8609E-01	45	9.3599E-01	9.1649E-01	9.5570E-01	83	3.4095E-01	2.3282E-01	4.4744E-01
8	9.8396E-01	9.8217E-01	9.8585E-01	46	9.3256E-01	9.1213E-01	9.5320E-01	84	3.1012E-01	2.0586E-01	4.1289E-01
9	9.8370E-01	9.8186E-01	9.8563E-01	47	9.2882E-01	9.0737E-01	9.5047E-01	85	2.7960E-01	1.8020E-01	3.7772E-01
10	9.8347E-01	9.8160E-01	9.8544E-01	48	9.2472E-01	9.0214E-01	9.4748E-01	86	2.4961E-01	1.5602E-01	3.4218E-01
11	9.8328E-01	9.8139E-01	9.8527E-01	49	9.2021E-01	8.9639E-01	9.4419E-01	87	2.2038E-01	1.3343E-01	3.0657E-01
12	9.8309E-01	9.8119E-01	9.8509E-01	50	9.1526E-01	8.9007E-01	9.4060E-01	88	1.9235E-01	1.1268E-01	2.7156E-01
13	9.8285E-01	9.8090E-01	9.8489E-01	51	9.0986E-01	8.8317E-01	9.3669E-01	89	1.6598E-01	9.3951E-02	2.3782E-01
14	9.8248E-01	9.8043E-01	9.8464E-01	52	9.0402E-01	8.7570E-01	9.3245E-01	90	1.4154E-01	7.7322E-02	2.0578E-01
15	9.8196E-01	9.7972E-01	9.8432E-01	53	8.9771E-01	8.6761E-01	9.2788E-01	91	1.1908E-01	6.2748E-02	1.7561E-01
16	9.8129E-01	9.7878E-01	9.8392E-01	54	8.9087E-01	8.5885E-01	9.2294E-01	92	9.8635E-02	5.0120E-02	1.4747E-01
17	9.8047E-01	9.7762E-01	9.8346E-01	55	8.8348E-01	8.4936E-01	9.1760E-01	93	8.0318E-02	3.9323E-02	1.2172E-01
18	9.7953E-01	9.7628E-01	9.8294E-01	56	8.7551E-01	8.3912E-01	9.1185E-01	94	6.4236E-02	3.0247E-02	9.8713E-02
19	9.7851E-01	9.7479E-01	9.8240E-01	57	8.6695E-01	8.2813E-01	9.0567E-01	95	5.0429E-02	2.2794E-02	7.8627E-02
20	9.7741E-01	9.7316E-01	9.8184E-01	58	8.5776E-01	8.1634E-01	8.9903E-01	96	3.8842E-02	1.6834E-02	6.1468E-02
21	9.7623E-01	9.7141E-01	9.8127E-01	59	8.4789E-01	8.0370E-01	8.9187E-01	97	2.9389E-02	1.2215E-02	4.7194E-02
22	9.7499E-01	9.6952E-01	9.8068E-01	60	8.3726E-01	7.9012E-01	8.8414E-01	98	2.1854E-02	8.7148E-03	3.5604E-02
23	9.7370E-01	9.6756E-01	9.8007E-01	61	8.2581E-01	7.7553E-01	8.7577E-01	99	1.5982E-02	6.1181E-03	2.6406E-02
24	9.7240E-01	9.6557E-01	9.7946E-01	62	8.1348E-01	7.5990E-01	8.6670E-01	100	1.1503E-02	4.2296E-03	1.9266E-02
25	9.7110E-01	9.6361E-01	9.7883E-01	63	8.0024E-01	7.4317E-01	8.5691E-01	101	8.1530E-03	2.8818E-03	1.3837E-02
26	9.6982E-01	9.6169E-01	9.7820E-01	64	7.8609E-01	7.2535E-01	8.4641E-01	102	5.6958E-03	1.9368E-03	9.7910E-03
27	9.6856E-01	9.5980E-01	9.7755E-01	65	7.7107E-01	7.0646E-01	8.3520E-01	103	3.9250E-03	1.2851E-03	6.8305E-03
28	9.6730E-01	9.5795E-01	9.7689E-01	66	7.5520E-01	6.8656E-01	8.2328E-01	104	2.6702E-03	8.4246E-04	4.7019E-03
29	9.6604E-01	9.5612E-01	9.7621E-01	67	7.3846E-01	6.6566E-01	8.1061E-01	105	1.7947E-03	5.4613E-04	3.1962E-03
30	9.6477E-01	9.5430E-01	9.7551E-01	68	7.2082E-01	6.4377E-01	7.9712E-01	106	1.1928E-03	3.5037E-04	2.1473E-03
31	9.6350E-01	9.5247E-01	9.7477E-01	69	7.0218E-01	6.2083E-01	7.8269E-01	107	7.8447E-04	2.2262E-04	1.4269E-03
32	9.6220E-01	9.5066E-01	9.7400E-01	70	6.8248E-01	5.9681E-01	7.6720E-01	108	5.1093E-04	1.4020E-04	9.3855E-04
33	9.6088E-01	9.4882E-01	9.7319E-01	71	6.6165E-01	5.7171E-01	7.5055E-01	109	3.2979E-04	8.7570E-05	6.1153E-04
34	9.5951E-01	9.4695E-01	9.7233E-01	72	6.3972E-01	5.4557E-01	7.3273E-01	110	2.1110E-04	5.4285E-05	3.9498E-04
35	9.5808E-01	9.4501E-01	9.7140E-01	73	6.1673E-01	5.1856E-01	7.1368E-01				
36	9.5655E-01	9.4297E-01	9.7039E-01	74	5.9279E-01	4.9088E-01	6.9340E-01				
37	9.5492E-01	9.4081E-01	9.6928E-01	75	5.6799E-01	4.6272E-01	6.7186E-01				

Average Life Expectancy = 73.777 years

were necessary with the previous method. The survival function decreases monotonically, which accounts for the fact that some deaths are expected to occur from causes other than radiation exposure at each age. This consideration becomes more important at later ages, since the baseline mortality rates generally increase with age. Accounting in this way assures that the radiation-induced excess cancer incidence risk is calculated for only the surviving population at any age.

4.2.2 Illustrative Examples

The examples presented here are designed to illustrate the principal features of the method for different radionuclides, cancer sites, and pathways of exposure. These examples consider the following radionuclides and exposure pathways: uniform low-LET radiation, exposure to external gamma rays due to Cs-137 in soil, inhalation of Pu-238, and ingestion of Sr-90. The Pu-238 example illustrates how high- and low-LET radiation dose rates and risks are combined to obtain the slope factor. Because of the large number of calculations involved, the derivation of a slope factor is tedious and computer codes are used to compile and organize the data and calculations that are required. Nevertheless, the purpose here is to present the basic elements of the derivation using a few simplified examples to illustrate the principal considerations.

For illustrative purposes, these simplified examples deviate from the actual methodology used by EPA in that the survival function, risk factors, and dose rates are averaged over the five discrete Risk Intervals, whereas the actual EPA calculations perform the integration on continuous functions for each parameter using a cubic spline function. For purposes of these examples, the survival function data from Table 4-1 have been averaged over the age intervals (risk intervals) for the risk model as shown in Table 3-1 (i.e., 0-9 y, 10-19 y, 20-29 y, 30-39 y, and 40+ y). (Note that these risk intervals differ from those used in EPA's previous methodology, as discussed in Appendix C.) Similarly, estimates of attributable cancer incidence risk per unit dose have been averaged over each risk interval for the purposes of these examples only. EPA's actual risk calculations utilize the more complete data sets for age-at-exposure values from 0 to 110 y for both the survival function (see Table 4-1) and the attributable incidence risk per unit dose (see Appendix B).

4.2.2.1 Example A: Risk Estimate for Uniform Low-LET Radiation. Example A considers chronic exposure to low-level low-LET radiation, where it is assumed that each member of the exposed population receives a uniform, constant dose rate of 1 mrad/y (10^{-5} Gy/y) to all body organs. For purposes of this and the following examples, the cohort survivors' life expectancy data from Table 4-1 have been aggregated over the age intervals for the risk model as shown in Table 3-1 (i.e., 0-9 y, 10-19 y, 20-29 y, 30-39 y, and 40+ y). These five intervals are denoted as "Risk Intervals" to distinguish them from other age intervals used in the calculations.

The survival function data from Table 4-1 are used in conjunction with the age-specific attributable cancer incidence risk per unit dose to estimate the total lifetime attributable cancer incidence risk resulting from uniform low-LET irradiation, assuming chronic equal dose rates to each body organ, as illustrated in Table 4-2. The Survival Function values in Table 4-2 were derived as the arithmetic averages of the age-specific values listed in Table 4-1 for each age contained in the respective Risk Interval. Similarly, the Interval Risk Factor for each Risk Interval was derived as the arithmetic average of the age-specific mortality risk coefficients for all cancer sites (see Table B-15), divided by an average lethality fraction of 0.67. Again, it is important to note that averaging over each Risk Interval is performed here for purposes of illustration only, and the complete set of age-specific risk coefficients and survival function values are utilized in EPA radiogenic risk calculations.

**Table 4-2. Attributable Cancer Risk from Uniform Low-LET Radiation
(chronic constant dose rate to all organs)**

Risk Interval (y)	Dose Rate (rad/y)	Survival Function (probability)	Interval Risk Factor (rad ⁻¹)	Attributable Cancers *
0-9	0.001	0.98665	1.6261E-3	1.60E-5
10-19	0.001	0.98169	1.5937E-3	1.56E-5
20-29	0.001	0.97175	7.1977E-4	6.99E-6
30-39	0.001	0.95849	6.3740E-4	6.11E-6
40-110	0.001	0.50565	2.1452E-4	<u>7.59E-6</u> 5.24E-5
Average individual risk = 5.24E-5 attributable cancers/(73.777 y x 1E-3 rad/y) = 7.1E-04 attributable cancers/rad				

* Computed as the product of the length of the risk interval, survival function value, dose rate, and interval risk factor.

Within each risk interval, the radiation-attributable cancer risk is computed as the product of the pertinent dose rate, survival function value, interval risk factor, and duration of the risk interval. The attributable cancer risks projected for each risk interval are summed to estimate the total attributable cancer risk over the lifetime of an average member of the exposed population under the assumed exposure conditions. Hence, a chronic dose rate of 1 mrad/y (10^{-5} Gy) in each body organ results in a lifetime attributable cancer risk of approximately 5×10^{-5} ; for comparison, the current baseline cancer incidence risk from all causes is about 0.3. The estimated lifetime attributable cancer risk per unit dose is computed as the lifetime attributable cancer risk divided by the total lifetime dose (0.07377 person-rad), or approximately 7.1×10^{-4} attributable cancers per person-rad. (Note that this estimate differs slightly from the value of 760 cancers per million person-rad in Table 3-1, due to the simplified calculational assumptions noted above.)

This illustration is simplistic in that it assumes identical dose rates in all body organs at all times. In many exposure situations, this is not the case, especially for internal exposures. In these cases, the dose rates at various ages must be appropriately averaged in the discrete risk intervals, as illustrated in the following examples.

4.2.2.2 Example B: External Exposure to Cs-137+D in Soil. Example B considers the case of chronic exposure to gamma radiation from Cs-137 in soil contaminated at a uniform level of 1 pCi of Cs-137 per gram of soil (1 pCi/g or 0.037 Bq/g). Cs-137 is a pure beta-emitter, which decays to Ba-137m with a half-life of approximately 30 years and a branching fraction of 0.946—i.e., 94.6% of all Cs-137 atoms decay to produce Ba-137m. For this example, Cs-137 is assumed to be in equilibrium with its radioactive decay product Ba-137m, i.e., the soil is also assumed to contain a uniform concentration of 0.946 pCi/g of Ba-137m per gram of soil (0.946 pCi/g or 0.035 Bq/g). This is a case where inclusion of the radioactive decay products is extremely important in estimating radiation risk, since the external pathway dose from this decay series is

entirely from Ba-137m. The inclusion of radioactive decay products in radionuclide slope factors is indicated as "Cs-137+D".

Although Cs-137 decays with a half-life of 30 years, the slope factor derivation assumes exposure to a constant and uniform soil contamination level, and constant dose rates in the various body organs and tissues. The decrease in radionuclide concentrations over time (i.e., by radioactive decay and also any physical removal processes) should be accounted for in pathway modeling used in conjunction with the slope factors to estimate risk. Conceptually, this can be accommodated by calculating the exposure-time integral in the appropriate units (e.g., pCi-y/g) and multiplying by the slope factor to obtain the lifetime risk.

In this example, however, it is assumed that the ground contamination level is constant and uniform. Thus, the dose rates in each body organ or tissue will also be constant over the lifetime of the exposed population. However, since some body organs and tissues are shielded by other organs or tissues, each can be subjected to a slightly different, but constant, dose rate. Since the dose rates in this example are constant over the life of the cohort, averaging dose rates over the five risk intervals is unnecessary.

Table 4-3 shows the simplified calculations for estimating attributable cancer risk for this example. The first column lists the risk intervals. The second lists the organ/tissue-specific dose rate for each risk interval. The third column lists the probability of survival for each risk interval (survival function). The fourth column lists the pertinent attributable cancer incidence risk per unit dose factors, derived from Appendix B. The last column is the predicted attributable cancer risk in each risk interval, calculated as the product of the pertinent dose rate, survival probability, interval risk factor, and interval duration. (As described in Section 4.2.2.1, the values of the survival function and interval risk factor for each risk interval are computed as arithmetic averages of the age-specific values within the respective risk interval.) This calculation is repeated for each risk interval and for each of the 14 cancer sites considered.

The slope factor is then computed as the cumulative lifetime attributable cancer risk summed over all cancer sites divided by the cumulative lifetime exposure. At the assumed constant soil contamination level of 1 pCi/g (0.037 Bq/g), the attributable cancer risk is estimated as approximately 1.5×10^{-4} . The cumulative exposure duration of the average member of the exposed population is 73.777 years. Thus, the slope factor may be calculated as

$$\begin{aligned} \text{SF} &= 1.54\text{E-}4 \text{ attributable cancers}/(73.777 \text{ y} \times 1 \text{ pCi/g}) \\ &= 2.09\text{E-}6 \text{ attributable cancers per pCi-y/g.} \end{aligned}$$

Table 4-3. Derivation of Attributable Cancer Risk Resulting from Chronic Exposure to Gamma Radiation from Cs-137+D Ground Contamination [1 pCi/g (0.037 Bq/g)]

Risk Interval (y)	Dose Rate (rad/y)	Survival Function (probability)	Interval Risk Factor (rad ⁻¹)	Attributable Cancers *
Breast				
0-9	3.54E-3	0.98665	2.2382E-4	7.82E-6
10-19	3.54E-3	0.98169	2.2486E-4	7.81E-6
20-29	3.54E-3	0.97175	1.0275E-4	3.53E-6
30-39	3.54E-3	0.95849	9.2426E-5	3.14E-6
40-110	3.54E-3	0.50565	1.0664E-5	<u>1.34E-6</u> 2.36E-5
Lung				
0-9	2.92E-3	0.98665	1.6406E-4	4.73E-6
10-19	2.92E-3	0.98169	1.6486E-4	4.73E-6
20-29	2.92E-3	0.97175	2.8309E-5	8.03E-7
30-39	2.92E-3	0.95849	5.8202E-5	1.63E-6
40-110	2.92E-3	0.50565	2.5979E-5	<u>2.69E-6</u> 1.46E-5
[etc. for each of the 14 cancer sites]				
Lifetime risk = 1.54E-4 attributable cancers				
Slope Factor = 1.54E-4 attributable cancers/(73.777 y x 1 pCi/g) = 2.09E-6 attributable cancers per pCi-y/g				

* Computed as the product of the length of the risk interval, survival function value, dose rate, and interval risk factor.

4.2.2.3 Example C: Inhalation of Pu-238. Example C considers the case of chronic inhalation of Pu-238 at a constant rate of 1 pCi/y (0.037 Bq/y). In the calculation of ingestion and inhalation slope factors, it is assumed that survivors in the cohort chronically ingest or inhale a constant amount of activity of a given radionuclide each year (e.g., 1 pCi/y) throughout each survivor's lifetime. Unlike the cases considered above, where the dose rates in body organs and tissues remained constant over time, in this example dose rates are not constant as survivors age, and average dose rates in each risk interval must be calculated.

For this example, it is assumed that the chemical form of the particles carrying the Pu-238 is insoluble in body fluids, i.e., the clearance time of the particles from the lung is very long (i.e., ICRP lung clearance class "Y"; see Appendix A). In this case, the dose rate to body organs and tissues increases rapidly during the first few years of exposure, and then plateaus asymptotically. For the purpose of this calculation, this means that dose rates will vary significantly over the risk interval 0-9 y, and then become relatively constant for subsequent intervals. Thus, an average dose rate for the 0-9 y interval must be calculated, taking into account the cohort survival. This is done by calculating the fraction of the time spent by survivors in the age groups within this risk interval. For the 0-9 y risk interval, three age groups are considered: 0-2, 2-4, and 4-10. Dose rates in the

middle of these age intervals, at 1, 3 and 6 y of age, are used to estimate the average dose rate in the 0-9 y interval. Similarly, a weighted average of the dose rate to each organ of interest is computed for each of the five risk intervals.

Since Pu-238 is an alpha-emitter and weak photon emitter, both high- and low-LET dose rates must be considered. The high-LET dose rates are adjusted for the greater relative biological effectiveness (RBE) of the alpha particles in inducing lung cancer, relative to beta and gamma radiation. EPA's revised methodology has adopted an RBE value of 20 for all cancer sites except leukemia, for which an RBE of 1 is assigned and breast which is assigned an RBE of 10. (Previously, EPA's risk estimates assumed an RBE of eight for estimating risks from alpha particles for all cancer sites; in 1992, the high-LET RBE for leukemia was reduced from 8 to 1.117, based on epidemiological data.)

The weighted average dose rates for each organ and tissue of interest are combined with the corresponding survival function data from Table 4-1 and the age-specific radiogenic cancer risk coefficients derived from Appendix B to estimate the radiation-attributable cancer risk in each risk interval, as illustrated in Table 4-4.

Table 4-4. Derivation of Attributable Cancer Risk Resulting from Chronic Inhalation of Pu-238 [1 pCi/y (0.037 Bq/y) constant intake rate]

Risk Interval (y)	Dose Rate (rad/y)	Survival Function (probability)	Interval Risk Factor (rad ⁻¹)	Attributable Cancers *
Lung				
High-LET Contribution				
0-9	4.31E-5	0.98665	20 x 1.6406E-4	1.40E-6
10-19	5.32E-5	0.98169	20 x 1.6486E-4	1.72E-6
20-29	5.33E-5	0.97175	20 x 2.8309E-5	2.93E-7
30-39	5.34E-5	0.95849	20 x 5.8202E-5	5.96E-7
40-110	5.35E-5	0.50565	20 x 2.5979E-5	<u>9.84E-7</u> 5.00E-6
Low-LET Contribution				
0-9	9.07E-8	0.98665	1.6406E-4	1.47E-10
10-19	1.12E-7	0.98169	1.6486E-4	1.81E-10
20-29	1.12E-7	0.97175	2.8309E-5	3.08E-11
30-39	1.12E-7	0.95849	5.8202E-5	6.25E-11
40-110	1.12E-7	0.50565	2.5979E-5	<u>1.03E-10</u> 5.23E-10
[etc. for each of the 14 cancer sites]				
Lifetime risk = 2.02E-6 attributable cancers				
Slope Factor = 2.02E-6 attributable cancers/(73.777 y x 1 pCi/y) = 2.74E-8 attributable cancers/pCi inhaled				

* Computed as the product of the length of the risk interval, survival function value, dose rate, and interval risk factor.

Under the assumed exposure conditions, the attributable cancer risk to an average member of the population inhaling 1 pCi/y of Pu-238 (Class Y) is estimated as approximately 2×10^{-6} . This attributable cancer risk may be divided by the cumulative lifetime exposure (intake) to estimate the radionuclide slope factor as follows:

$$\begin{aligned} \text{SF} &= 2.02\text{E-}6 \text{ attributable cancers} / (73.777 \text{ y} \times 1 \text{ pCi/y}) \\ &= 2.74\text{E-}8 \text{ attributable cancers/pCi inhaled} \end{aligned}$$

4.2.2.4 Example D: Ingestion of Sr-90. Example D considers the case of chronic ingestion of Sr-90 at a constant rate of 1 pCi/y over a lifetime. It is assumed here that the chemical form of the Sr-90 is soluble in the gastrointestinal tract, with a GI-tract-to-blood absorption fraction (f_1) of 0.3. Since strontium accumulates preferentially in the skeletal tissues, the dose rates to these tissues exceed those for other body organs or tissues; therefore, this example focuses on attributable risk of bone sarcoma and leukemia (red bone marrow). The annual dose rates computed by RADRISK for these tissues increase with time, due to the accumulation of Sr-90 in these tissues—i.e., the deposition and retention of Sr-90 in bone surfaces and red bone marrow greatly exceeds its biological and radiological removal rate.

Since the dose rates to bone surface and red marrow are not constant, average dose rates in each of the five risk intervals are calculated. For each cancer site, the dose rate within each risk interval is calculated as a weighted average based on the fraction of time spent by survivors in each age group within this risk interval. Attributable cancer risk for this case is calculated as shown in Table 4-5. For each cancer site in each risk interval, the average dose rates are multiplied by the probability of survival for that interval, and the attributable cancer incidence risk per unit dose (derived from Appendix B) to estimate the attributable risk for that interval. The sum of these products is divided by the total lifetime intake to obtain the slope factor. Under the assumed exposure conditions, the attributable cancer risk is estimated at approximately 4×10^{-9} ; this represents an average individual risk of approximately four chances in a billion, in this example. This attributable cancer risk may be divided by the cumulative lifetime exposure (intake) to estimate the radionuclide slope factor for ingestion of Sr-90 as

$$\begin{aligned} \text{SF} &= 4.12\text{E-}9 \text{ attributable cancers} / (73.777 \text{ y} \times 1 \text{ pCi/y}) \\ &= 5.59\text{E-}11 \text{ pCi}^{-1} \text{ ingested.} \end{aligned}$$

4.3 SUMMARY

Radionuclide slope factors express the lifetime attributable cancer risk per unit exposure to a given radionuclide, where exposure is measured in units of activity intake (pCi or Bq) for inhalation and ingestion, or in units of soil concentration times exposure duration for external exposure [e.g., soil concentration (pCi/g or Bq/g) \times time (y) = pCi-y/g or Bq-y/g]. The slope factor represents the total attributable cancer risk for all organs and cancer sites. In practice, the attributable cancer risk for each organ or cancer site is estimated

Table 4-5. Derivation of Attributable Cancer Risk Resulting from Chronic Ingestion of Sr-90 [1 pCi/y (0.037 Bq/y) constant intake rate]

Risk Interval (y)	Dose Rate (rad/y)	Survival Function (probability)	Interval Risk Factor (rad ⁻¹)	Attributable Cancers *
Leukemia				
0-9	2.96E-7	0.98665	7.3982E-5	2.16E-10
10-19	5.60E-7	0.98169	3.0404E-5	1.67E-10
20-29	6.28E-7	0.97175	5.3010E-5	3.23E-10
30-39	6.49E-7	0.95849	6.0724E-5	3.78E-10
40+	6.51E-7	0.50565	3.1630E-5	<u>7.29E-10</u> 1.81E-09
Bone Sarcoma				
0-9	4.89E-7	0.98665	1.6363E-6	7.90E-12
10-19	1.04E-7	0.98169	1.6254E-6	1.66E-11
20-29	1.27E-7	0.97175	1.6060E-6	1.99E-11
30-39	1.42E-7	0.95849	1.5647E-6	2.13E-11
40+	1.47E-7	0.50565	6.8341E-7	<u>3.56E-11</u> 1.01E-10
[etc. for each of the 14 cancer sites]				
Lifetime risk = 4.12E-9 attributable cancers				
Slope Factor = 4.12E-9 attributable cancers/(73.777 y x 1 pCi/y) = 5.59E-11 attributable cancer/pCi ingested				

* Computed as the product of the length of the risk interval, survival function value, dose rate, and interval risk factor.

separately based upon organ/tissue-specific dose rates and risk coefficients, and these individual organ risks are summed to estimate total attributable risk. Dose rates to each organ and tissue may vary as a function of age and time after exposure, and the organ/tissue-specific risk coefficients may vary as a function of age and sex.

In the derivation of radionuclide slope factors, chronic exposure, at a constant exposure rate, is assumed for each radionuclide of concern. For chronic inhalation and ingestion exposures, dose rates to body organs and tissues may increase with time following the beginning of exposure, as a result of the accumulation of activity within the body. For the chronic external exposures, it is assumed that dose rates to each organ and tissue remain constant with time. In all cases, the lifetime attributable cancer risk accumulates with age.

Since the radionuclide slope factors represent the attributable risk of cancer incidence, it is necessary to account for competing risks (i.e., risks from sources other than radiation exposure). Life tables and survival functions based on actuarial data are used to account for such competing risks, and to estimate the probability of survival and projected years of life remaining at various ages in a reference population. This estimate of the remaining

years of life for the members of the exposed population at each age is considered to be the period available for expression of the radiogenic cancer risk.

For each age of exposure and for each cancer site considered, the attributable risk of cancer at that site due to the dose accumulated at that age from a given exposure pathway is based on the organ/tissue-specific absorbed dose rate in that year (rad/y or Gy/y), the organ/tissue-specific cancer risk per unit absorbed dose at that age (rad⁻¹ or Gy⁻¹), and the survival function or reference life table data. The attributable cancer risk for each cancer site at each age is computed in this manner and summed to obtain the total number of radiogenic cancers of all types expected in the life of the exposed population. This total is then divided by the collective lifetime (person-years) of the exposed population and the lifetime activity intake rate to obtain a slope factor for ingestion and/or inhalation. An analogous procedure is used for external exposure, except the collective lifetime exposure is substituted for the lifetime intake. This estimate of attributable risk applies to an age-averaged member of the exposed population.

This procedure is followed for each radionuclide. For alpha-emitters, the risks due to the high-LET (alpha) radiation are calculated separately from those due to low-LET radiations (beta and gamma), and these are summed to obtain the slope factor for the radionuclide.

In summary, the calculation of the radionuclide slope factor is based upon three principal types of data:

- Organ/tissue-specific dose rates are computed for each tissue of interest over the lifetime of the exposed population. Dose rates are calculated using the RADRISK code (Du80) for ingestion and inhalation assuming constant annual intake of activity, e.g., a constant intake rate of 1 pCi/y (0.037 Bq/y). For external exposure, the computer code DFSOIL (Sj84) is used to calculate the constant dose rates in body organs and tissues that result from gamma radiation emitted by a radionuclide uniformly distributed in soil at a constant unit concentration (pCi/g or Bq/g).
- Lifetime attributable cancer incidence risks per unit dose [e.g., expected cancer cases (risk) per 10⁶ rad or per 10⁴ Gy] have been computed for specific cancer sites and ages. As discussed previously, the risk estimates used by EPA for derivation of the radionuclide slope factors differ under the current and previous EPA methodologies. Risk estimates used in EPA's previous methodology were based primarily upon the National Academy of Sciences BEIR III study (NAS80), whereas risk estimates under the revised methodology are based primarily upon recommendations of the ICRP (ICRP91), NRC (Gi91), and NCRP (NCRP85).
- Vital statistics and mortality data for the reference population are used to account for competing risks, and to estimate the projected years of life remaining at various ages in the reference population (i.e., the period available for expression of the radiogenic cancer risk). EPA's derivation of radionuclide slope factors prior to 1994 utilized life table data for the 1970 decennial U.S. population, as implemented in the CAIRD computer code (Co78). The revised methodology (EPA94a) utilizes vital statistics and mortality data for the 1980 decennial U.S. population (NCHS85, 84, 83, 82) to estimate competing risks and the projected years of life remaining at various ages in the reference population; the discrete mortality data are fit to a

cubic spline function, from which interpolated values, derivatives, and integrals are calculated directly from the spline coefficients.

Detailed discussion of the calculational methods, assumptions, and uncertainties in the EPA methodology for estimating radiogenic cancer risk is provided in another EPA document, *Estimating Radiogenic Cancer Risks* (EPA94a). A summary of the methodology used by EPA for derivation of radionuclide slope factors prior to 1994 is presented in Appendix C, and more detailed discussion of these calculations may be found in Reference EPA89b.

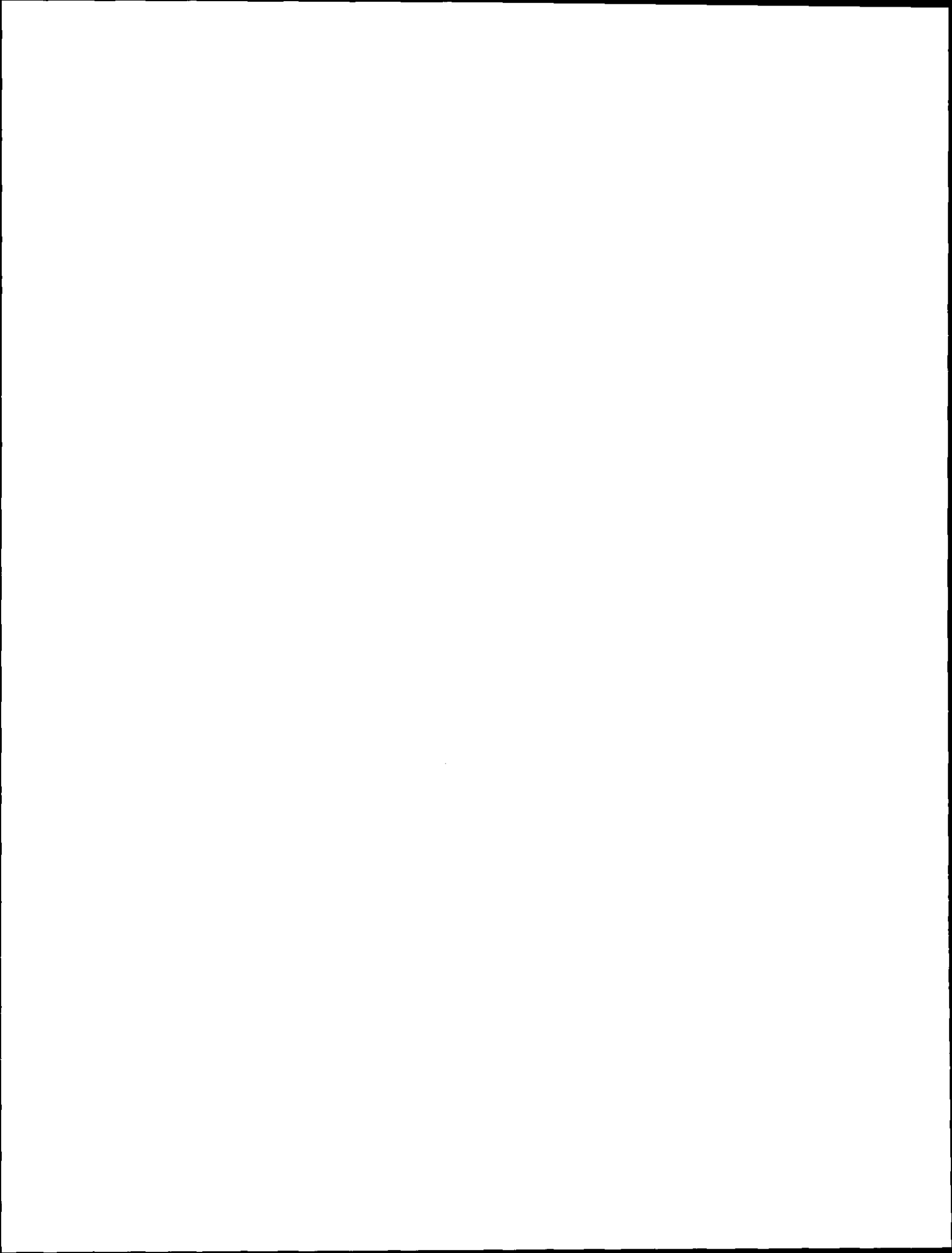

Chapter 5

Uncertainty in Radionuclide Slope Factors

Estimates of health risk from low-level radiation exposures are inherently uncertain. Consideration of uncertainties in estimates of risk is an important component of the risk assessment process (EPA89a, EPA92a). This chapter presents a general discussion of the major sources of uncertainty in estimating risks from environmental exposures to radioactive substances. The major sources of uncertainty in the radionuclide slope factors are those pertaining to the underlying models used to estimate radiation dose and to relate dose to radiation-induced cancer risk. Some of these uncertainties are not well quantified, and a quantitative uncertainty analysis of the radionuclide slope factors has not been completed. However, a general understanding of the uncertainty inherent in the radionuclide slope factors is important for the assessment and management of radiation-related risks. Full disclosure of the limitations and uncertainties in risk estimates is needed for informed risk management decisions.

Rather than using mathematical models to assess impacts of radioactive materials in the environment, it would be preferable to measure the actual impacts directly; i.e., radionuclide concentrations and radiation fields in the environment, radionuclide concentrations and absorbed doses in the various organs and tissues of the exposed populations, and any increased incidence of cancer attributable to the exposures. However, this is not possible because the radionuclide exposures are not generally detectable in members of the population, and any excess cancers that may be attributable to radionuclide exposures cannot be identified in the presence of the large numbers of baseline cancers in the population. Accordingly, the actual or potential impacts of environmental radiation exposures must be predicted using calculational models, and the uncertainty in radiation risk assessments must be discussed within the framework of the models and parameters used to estimate risks that cannot be measured.

In the preceding discussions regarding radionuclide slope factors and their application in estimating radiation risk, doses and risks from radiation exposure have been presented as discrete values; i.e., rad/year or lifetime excess cancer risk. Each of these calculated values is an expression of impact on an individual or population. These values are intended to be reasonable central estimates of risk, i.e., to not significantly underestimate or overestimate risks and be of sufficient accuracy to support decision making. However, such values are of more use to decision-makers when there is some characterization of their uncertainty. For a given exposure scenario, a small risk may be calculated, e.g., 1×10^{-6} lifetime risk of cancer for an individual. However, if the uncertainty in this number is several orders of magnitude, the real risk from this source of exposure may in fact be higher than another source of exposure which has a calculated risk of 1×10^{-5} lifetime risk of cancer but has a small degree of uncertainty. Alternatively, an upper bound risk of 1×10^{-2} lifetime risk may be calculated and appear to represent an unacceptable risk. However, the actual risk may be orders of magnitude smaller. This situation may occur when, due to limited information and uncertainty in the calculational parameters, conservative assumptions (i.e., assumptions likely to overestimate actual values) are used throughout the

calculation in order to ensure that the risks are not underestimated. This can result in a risk estimate that is near or beyond the upper limit of what is plausible, because it is based on a very unlikely combination of conservative assumptions for each parameter.

5.1 SOURCES OF UNCERTAINTY IN RADIATION DOSIMETRY

Radiation dosimetry models are designed to simulate the uptake, distribution, retention and removal of radioactive materials in the human body. At best, these models can only approximate real situations in organs and tissues in humans. In applying the internal dosimetry models in current use, the primary sources of uncertainty are attributed to model formulation and parameter variability produced by measurement error or natural variation. These sources include:

- Uncertainty in the formulation of the mathematical models for
 - deposition of activity in the lung and translocation of inhaled activity into blood,
 - translocation and absorption of ingested activity into the blood,
 - distribution and retention of activity from blood to various systemic organs and tissues, and
 - calculation of the absorbed dose to an organ or tissue from activity in that and other organs and tissues;
- Uncertainty in the model parameters, including
 - parameters in the biokinetic and dose models (e.g., GI absorption fraction, lung clearance class, organ deposition fractions and retention times, organ masses and geometries, etc.), and
 - anatomical and physiological data for characterizing the population of interest.

The dosimetric models and data have been developed primarily in the context of radiation protection for adult workers, and represent average adult male members of the population; consequently, they do not account for variability in the physiological and metabolic characteristics among individuals within a population or across populations, or in the metabolic behavior of radionuclides, which vary depending on age, sex, and dietary intakes of an individual at the time of exposure. Despite the obvious differences between risk assessment and occupational radiation protection, the dosimetric formulations of the latter have been generally adopted, often with little or no modifications, in risk assessment activities. This approach permits use of a substantial body of information assembled by international experts from the occupational setting and provides models that avoid the complex problems encountered in biokinetic modeling of radionuclides for the general public in an age-dependent sense. More recently, dosimetric models and data which incorporate organ/tissue-specific biokinetics and age-dependence have become available (ICRP89, 93, 95a, 95b). These estimates of dose per unit exposure tend to be higher for children than for adults by factors ranging up to approximately an order of magnitude. These age-dependent dose estimates, however, are not yet incorporated into the radionuclide slope factors.

The radionuclide slope factors represent the risk to an average individual due to chronic lifetime exposures. Variation in dosimetric parameters between people and between age groups is of reduced importance in this context because such variation gets averaged over a population and/or over a lifetime. Nevertheless, parameter

variability can contribute substantially to the uncertainty in the dose and risk estimates, and it should be kept in mind that some individuals in a population are going to be at higher or lower risk from a given exposure.

Parameter variation among individuals contributes uncertainty to the models by causing random errors in any measured human data upon which the dosimetric models are based. To the extent that the subjects from whom such data are collected are atypical of the U.S. population (e.g., with respect to health status), parameter variation may also be a source of bias. Since the parameters contained in the dosimetric models were estimated primarily for adult males, they may not provide an adequate basis for calculating the average dose or risk in cases where age- and sex-related variations in these parameters are large. This problem becomes more significant in light of the generally higher risks associated with a given dose for childhood exposures; if doses are also higher in childhood, the enhanced effect on risk will be compounded. In addition, some of the biokinetic models used for dosimetry calculations are based on very limited observational data in humans or constructed largely from animal data.

Also, the distribution of an element within an organ or tissue may not be uniform, particularly with respect to biological targets of interest. This can be a serious problem with respect to the estimation of relevant doses from internally deposited alpha emitters, given the short range of alpha particles in matter. For example, where an alpha emitter is distributed nonuniformly in bone, the calculation of doses to sensitive cells in the bone and the bone marrow will be difficult. Another example is the uncertainty in estimating doses to cells lining the GI tract from ingested alpha emitters passing through the tract; in some cases, the mucus lining may effectively shield the target cells from irradiation.

Estimates of external dose also suffer similar limitations. These estimates are based on assumptions of uniform radionuclide concentrations within a semi-infinite geometry of the source region. The radiation field between the feet and the head of a person standing on contaminated ground is not uniform, but for photon energies greater than about 10 keV, the variation about the value at 1 meter becomes minimal. A more significant source of error is the assumption of a uniform radionuclide concentration in soil. Kocher (Ko81b) has shown that sources would have to be approximately uniform over distances of as much as a few hundred meters from the receptor for the dose rate factors to be accurate for ground surface exposures. Factors such as penetration of deposited radionuclides into the ground surface, ground surface roughness, terrain irregularities, and shielding provided by any buildings or structures that may be present, are likely to reduce actual doses below the theoretical estimates.

Additional uncertainty arises from the factors used to relate the dose in air above a contaminated ground surface to the dose in various organs of the body. These factors assume that the radiation field for the ground surface source is isotropic and has the same energy distribution as for immersion in contaminated air. These assumptions clearly do not hold true, but more precise estimates of these distributions are not likely to change the organ dose rate factors substantially.

5.2 SOURCES OF UNCERTAINTY IN RADIOGENIC RISK MODELS

Important sources of uncertainty inherent in current estimates of risk from whole body, low-LET radiation include:

- the extrapolation of risks observed in populations exposed to relatively high doses, delivered acutely, to populations receiving relatively low dose chronic exposures—i.e., the form of the dose-response function and any dependence on dose rate;
- the projection of risk over a full lifespan, including consideration of age at exposure, sex, and other factors (e.g., the extent to which high relative risks seen over a limited follow-up period among individuals exposed at young ages carry over into later years of life when baseline cancer incidence rates are high); and
- the "transport" of risks observed in one population to another population of different characteristics (e.g., different baseline cancer risks, diets, and lifestyles).

The most important source of epidemiological data on radiogenic cancer is the Atomic Bomb Survivor Study. The population of survivors of the atomic bomb detonations in Hiroshima and Nagasaki have been studied for more than 40 years in a carefully planned and monitored epidemiological survey. They are the largest group that has been studied, and they provide the most detailed information on the response pattern for organs, by age and sex, over a wide range of doses of low-LET radiation. However, use of these data for estimating risks to the U.S. population from exposure to low doses and dose rates of radiation is subject to each of the three major uncertainties noted above. Most of the epidemiological data pertain to acute doses of 50 rad (0.5 Gy) or higher; extrapolation of these data to much smaller chronic doses incremental to the natural background level of about 100 mrad/yr (1 mGy/yr)(excluding indoor radon) is highly uncertain. Since epidemiological follow-up of the irradiated population is still incomplete, projection beyond the period of observation is required to obtain lifetime risk estimates.

Also, the transportation of the atomic bomb survivor data to the U.S. population is an area of significant uncertainty. Baseline rates for specific cancer types vary from population to population, and over time within a given population. For example, stomach cancer rates are substantially higher in Japan than in the U.S., while the reverse is true for lung, colon, and breast cancer; moreover, the incidence rates for lung and breast cancer, particularly, have been increasing in both populations during recent years. Despite the observed rough proportionality between radiation risk and baseline cancer rates by age, the radiation risk will not necessarily vary in proportion to the baseline cancer rate between different populations. Information on how to transport risk estimates between populations is currently very limited; the available information suggests that the method may be dependent on the specific cancer site. Given this uncertainty in the transportation of risks across populations, EPA has adopted a model in which age- and site-specific risk coefficients are taken as the geometric means of two models proposed by the ICRP for transporting risks from the Japanese to U.S. populations.

In addition to these model uncertainties, errors in dosimetry and random statistical variations also contribute to the uncertainty in the risk estimates for the atomic bomb survivors. Significant errors were identified and corrected in the estimates of radiation doses received by the exposed population, leading to the replacement of the "T65" (tentative dose 1965) dose estimates by the "DS86" (dosimetry system 1986) dose estimates. The residual error of the DS86 dosimetry is generally estimated to be a relatively minor contributor to the overall uncertainty, with an overall uncertainty in individual doses on the order of $\pm 30\%$ (Ka89). Recent estimates of neutron doses (Pr93) may lead to further revision of these uncertainty estimates.

The precision of risk estimates is also limited by sampling uncertainties due to the limited sample size. Uncertainties due to sampling error are larger where data are sparse, e.g. with respect to risks for specific age groups or specific cancer sites (Sh88). Finally, there will be some error in ascertaining cancer cases, such as under-reporting of cases or mislabeling of cancer type. Both of these types of error tend to bias risk estimates slightly downward.

Additional sources of epidemiological data on exposures to low-LET radiation include medical exposures of specific tissues, notably the thyroid and breast. These data are also subject to the same types of uncertainties noted above.

Uncertainties in risk estimates for internally deposited alpha emitters are often greater than for low-LET radiation, with the notable exception of lung cancer risk from inhalation of radon decay products. For many organs and tissues, no human epidemiological data are available for alpha exposures, so extrapolation from low-LET radiation is required. For other sites where epidemiological data are available, risk estimates are complicated by uncertainties in dosimetry. Excess cancers have been observed in certain human populations exposed occupationally or medically to internally deposited alpha emitters, including: (1) lung cancer in miners inhaling radon decay products; (2) bone cancer in patients injected with radium-224; (3) bone sarcomas and head carcinomas in watch dial painters ingesting mixtures of radium-226 and radium-228; and (3) liver cancers in patients injected with Thorotrast, an x-ray contrast medium containing isotopes of thorium. Although other organs and tissues of the body received doses of alpha radiation in these populations, excess cancers were generally not observed at sites other than those listed. As a result, only upper bounds to the risk for these other organs and tissues can be estimated directly from studies of humans exposed to alpha radiation.

For other sites, cancer risk estimates for high-LET radiation are often derived from human epidemiological data on low-LET radiation and laboratory data on the relative biological effectiveness (RBE) of the high-LET radiation. The assumptions regarding the RBE for alpha irradiation are generally derived from high dose experiments on animals. The available evidence on cells, animals, and humans points to a linear dose response relationship for the risk from alpha emitters (NAS88). The extrapolation to low doses is therefore considered to be less important as a source of uncertainty for alpha irradiation than for low-LET irradiation. There is, however, considerable variability in the RBE determined from animal studies; the extrapolation of these results to humans is also a significant source of uncertainty.

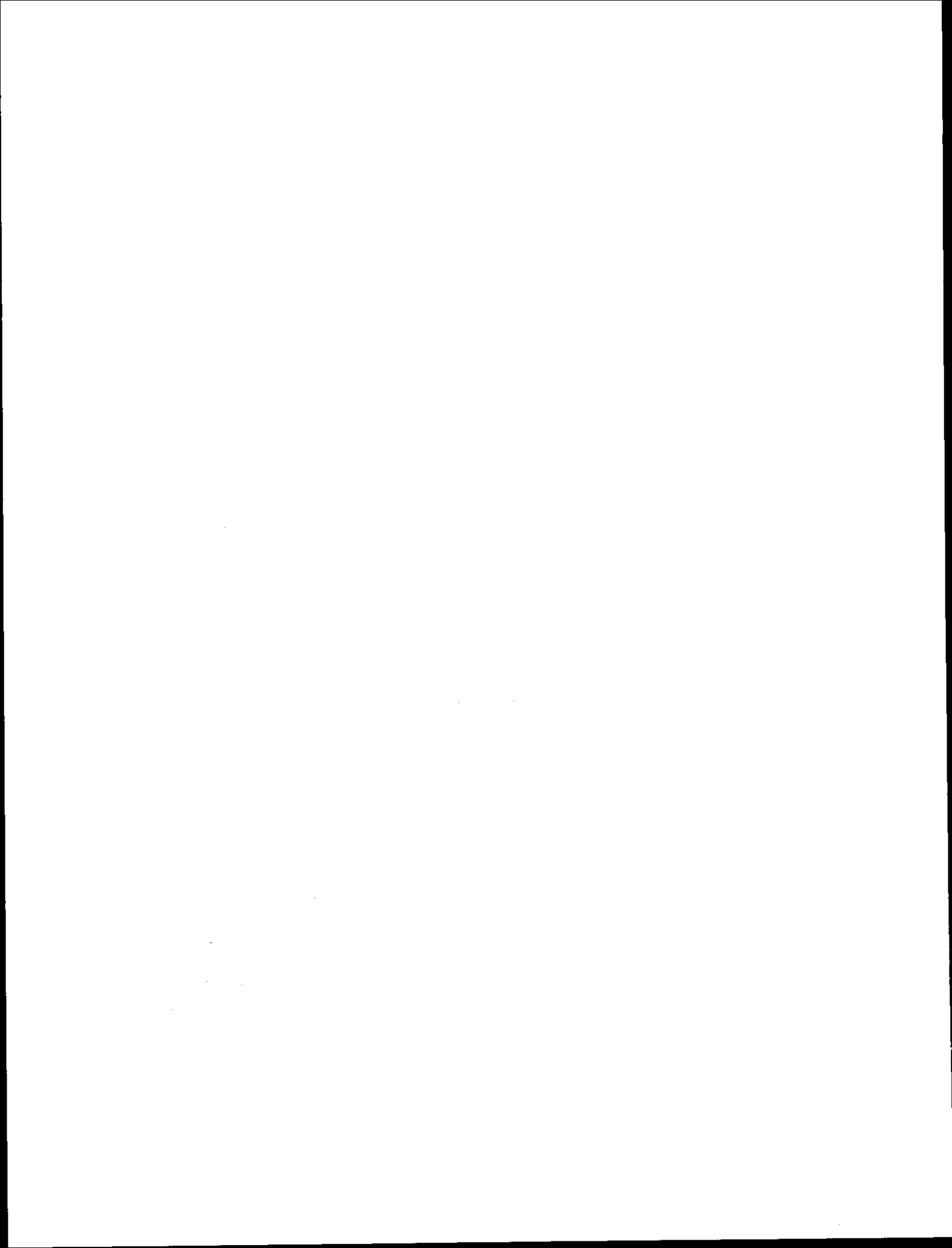

References

- Ar81 Archer, V.E., "Health Concerns in Uranium Mining and Milling", J. Occup. Med. **23**, 502-505, 1981.
- Be77 Beebe, G.W., Kato, H., and Land, C.E., Mortality Experience of Atomic Bomb Survivors, 1950-1974, Life Span Study Report 8, RERF TR 1-77, Radiation Effects Research Foundation, Japan, 1977.
- Bu81 Bungler, B., Cook, J.R. and M.K. Barrick, "Life Table Methodology for Evaluating Radiation Risk: An Application Based on Occupational Exposure", Health Phys. **40** (4):439-455, 1981.
- Ch81 Chameaud, J., Perraud, R., Chretien, J., Masse, R. and J. Lafuma, "Contribution of Animal Experimentation to the Interpretation of Human Epidemiological Data", in: Proc. Int. Conf. on Hazards in Mining: Control, Measurement, and Medical Aspects, October 4-9, 1981, Golden, Colorado, pp. 228-235, edited by Manuel Gomez, Society of Mining Engineers, New York, 1981.
- CIRR92 Committee on Interagency Radiation Research and Policy Coordination, "Use of BEIR V and UNSCEAR 1988 in Radiation Risk Assessment," Office of Science and Technology Policy (Available as ORAU 92/F-64 through NTIS, Springfield, VA), 1992.
- Co78 J.R. Cook, B.M. Bungler, and M.K. Barrick, A Computer Code for Cohort Analysis of Increased Risks of Death (CAIRD), EPA 520/4-78-012, U.S. EPA, June 1978.
- Cr88 Crick, M.J., et al., Uncertainty Analysis of the Foodchain and Atmospheric Dispersion Modules of MARC, NRPB-R184, May 1988
- Da75 Davies, R.B. and B. Hulton, "The Effects of Errors in the Independent Variables in a Linear Regression", Biometrika **62**:383-391, 1975.
- Da86 Darby, S.C., "Epidemiological Evaluation of Radiation Risk Using Populations Exposed at High Doses", Health Phys. **51** (3): 269-281, 1986.
- Da89 Davis, F.G., J.D. Boice, Z. Hrubek, and R.R. Monson, "Cancer Mortality in a Radiation-Exposed Cohort of Massachusetts Tuberculosis Patients". Cancer Res. **49**, 6130-6136, 1989.
- Du80 Dunning, D.E. Jr., Leggett, R.W., and Yalcintas, M.G., A Combined Methodology for Estimating Dose Rates and Health Effects from Exposure to Radioactive Pollutants, ORNL/TM-7105, 1980.
- EPA86 Environmental Protection Agency, Superfund Public Health Evaluation Manual, EPA/540/1-86/060, OSWER Directive 9285.4-1, 1986.
- EPA88 Environmental Protection Agency, Federal Guidance Report No. 11, Limiting Values of Radionuclide Intake and Air Concentration and Dose Conversion Factors for Inhalation, Submersion and Ingestion, EPA-520/1-88/020, September 1988.

- EPA89a Environmental Protection Agency, Risk Assessment Guidance for Superfund Volume 1 Human Health Evaluation Manual (Part A), Interim Final, EPA/540/1-89/002, USEPA, Washington, 1989.
- EPA89b Environmental Protection Agency, Risk Assessments Methodology. Environmental Impact Statement, NESHAPs for Radionuclides, Background Information Document - Volume 1 EPA/520/1-89-005. USEPA, Washington, 1989.
- EPA90 Environmental Protection Agency, 40 CFR Part 300, National Oil and Hazardous Substances Pollution Contingency Plan; Final Rule, Federal Register, v. 55, n. 46, p. 8666, March 8, 1990.
- EPA91a Environmental Protection Agency, Risk Assessment Guidance for Superfund Volume 1 Human Health Evaluation Manual (Part B, Development of Risk-Based Preliminary Remediation Goals), Interim Final, EPA/540/R-92/003, December 1991.
- EPA91b Environmental Protection Agency, Risk Assessment Guidance for Superfund Volume 1 Human Health Evaluation Manual (Part C, Risk Evaluation of Remedial Alternatives), Interim Final, EPA/540/R-92/004, December 1991.
- EPA91c Environmental Protection Agency, Drinking Water Criteria Document on Radium (Final Draft), NTIS: PB 91225631, 1991.
- EPA92a Environmental Protection Agency, "Guidance on Risk Characterization for Risk Managers and Risk Assessors," Memorandum from F.H.Habicht, February 26, 1992.
- EPA92b Environmental Protection Agency, Technical Support Document for the 1992 Citizen's Guide to Radon, EPA 400-R-92-011, 1992.
- EPA92c Environmental Protection Agency, Guidance for Data Useability in Risk Assessment, Part B, 9285.7-09B, PB92-963362, April 1992.
- EPA93 Environmental Protection Agency, Federal Guidance Report 12, External Exposure to Radionuclides in Air, Water, and Soil, EPA 402-R-93-081, September 1993.
- EPA94a Environmental Protection Agency, Estimating Radiogenic Cancer Risks, J.S. Puskin and C.B. Nelson, Office of Radiation and Indoor Air. EPA 402-R-93-076, June 1994.
- EPA94b Environmental Protection Agency, Report to Congress: Multimedia Risk and Cost Assessment of Radon, EPA 811-R-94-001.
- EPA95 Environmental Protection Agency, Health Effects Assessment Summary Tables, FY-1995, Office of Solid Waste and Emergency Response, EPA/540/R-95/142, PB95-921101, Nov. 1995.
- EPA96 Environmental Protection Agency, Integrated Risk Information System, 1996.
- Gi91 Gilbert, E.S., "Chapter 3: Late Somatic Effects," In: Health Effects Models for Nuclear Power Plant Accident Consequence Analysis. Modifications of Models Resulting from Recent Reports on Health Effects of Ionizing Radiation. NUREG/CR-4214, Rev. 1, Part II, Addendum 1, LMF-132, 1991.

- Gr85 Grosovsky, A.J. and J.B. Little, Evidence for Linear Response for the Induction of Mutations in Human Cells by X-Ray Exposures below 10 Rads, Proc. Natl. Acad. Sci. USA, 82, 2092-2095, 1985.
- Ho81 Hornung, R. W. and S. Samuels, "Survivorship Models for Lung Cancer Mortality in Uranium Miners - Is Cumulative Dose an Appropriate Measure of Exposure?", in: Proc. Int. Conf. on Hazards in Mining: Control, Measurement, and Medical Aspects, October 4-9, 1981, Golden, Colorado, 363-368, Manuel Gomez, Ed., Society of Mining Engineers, New York, 1981.
- Ho85 Hofer, E., and Krzykacz, B., CEC Study Contract: Uncertainty analysis of the computational assessment of the radiological consequences of nuclear accidents, Final Report to Part I (October 1984) and to Part II (July 1985).
- Ho92 Howe, G.R., "Effects of Dose, Dose Rate and Fractionation on Radiation Induced Breast and Lung Cancers: the Canadian Fluoroscopy Study". In: International Conference on Radiation Effects and Protection, pp 108-113, Japan Atomic Energy Research Institute, Tokyo, 1992.
- ICRP66 ICRP Task Group on Lung Dynamics, "Depositions and Retention Models for Internal Dosimetry of the Human Respiratory Tract," Health Phys., 12(2):173-207, 1966.
- ICRP77 International Commission on Radiological Protection, Recommendations of the International Commission on Radiological Protection, ICRP Publication 26, Annals of the ICRP, 1 (3), Pergamon Press, Oxford, 1977.
- ICRP79 International Commission on Radiological Protection, Limits for Intakes of Radionuclides by Workers, ICRP Publication 30, Part 1, Ann. ICRP, 2 (3/4), Pergamon Press, New York, 1979.
- ICRP86 International Commission on Radiological Protection, The Metabolism of Plutonium and Related Elements, ICRP Publication 48, Pergamon Press, NY, 1986.
- ICRP87 International Commission on Radiological Protection, Lung Cancer Risk from Indoor Exposures to Radon Daughters, ICRP Publication 50, Pergamon Press, NY, 1987.
- ICRP89 International Commission on Radiological Protection, Age-Dependent Doses to Members of the Public from Intake of Radionuclides: Part 1, ICRP Publication 56, 1989.
- ICRP91 International Commission on Radiological Protection, 1990 Recommendations of the International Commission on Radiological Protection. Annals of the ICRP, 21 (1-3), 1991.
- ICRP93 International Commission on Radiological Protection, Age-Dependent Doses to Members of the Public from Intake of Radionuclides: Part 2, ICRP Publication 67, 1993.
- ICRP95a International Commission on Radiological Protection, Age-Dependent Doses to Members of the Public from Intake of Radionuclides: Part 3, ICRP Publication 69, 1995.
- ICRP95b International Commission on Radiological Protection, Age-Dependent Doses to Members of the Public from Intake of Radionuclides: Part 4, ICRP Publication 71, 1995.

- Ka82 Kato, H. and W.J. Schull, "Studies of the Mortality of A-bomb Survivors, 7. Mortality, 1950-1978: Part I, Cancer Mortality", Rad. Research 90, 395-432, 1982, (Also published by the Radiation Effect Research Foundation as: RERF TR 12-80, Life Span Study Report 9, Part 1.)
- Ka89 Kaul, D.C., Uncertainty Analysis of DS86 Dosimetry System, RERF Update 1 (2), 4, 1989.
- Ko81a Kocher, D.C., and Eckerman, K.F., "Electron Dose-Rate Conversion Factors for External Exposure of the Skin", Health Phys., 40(1):67, 1981.
- Ko81b Kocher, D.C., "Dose-Rate Conversion Factors for External Exposure to Photon and Electron Radiation from Radionuclides Occurring in Routine Releases from Nuclear Fuel-Cycle Facilities", Health Phys., 38(4):543-621, 1981. (See also NUREG/CR-1918, ORNL/NUREG-79.)
- Ko81c Kocher, D.C., Dose Rate Conversion Factors for External Exposure to Photons and Electrons, NUREG/CR-1918 (ORNL/NUREG-79), Oak Ridge National Laboratory, Oak Ridge, TN, 1981.
- La80 Land, C.E., Boice, J.D., Shore, R.E., Norman, J.E. and M. Tokunaga, et al., "Breast Cancer Risk from Low-Dose Exposures to Ionizing Radiation: Results of Parallel Analysis of Three Exposed Populations of Women", J. Natl. Canc. Inst., 65, 353-376, 1980.
- La83 Land, C.E. and D.A. Pierce, "Some Statistical Considerations Related to the Estimation of Cancer Risk Following Exposure to Ionizing Radiation", pp. 67-89, in Epidemiology Applied to Health Phys., CONF-830101, DE83014383, NTIS, Springfield, Virginia, 1983.
- La91 Land, C.E. and W.K. Sinclair, "The relative contributions of different organ sites to the total cancer mortality associated with low-dose radiation exposure". In: Risks Associated with Ionising Radiations, Annals of the ICRP 22, No. 1, 1991.
- Ma83 Mays, C.W. and H. Spiess, "Epidemiological Studies in German Patients Injected with Ra-224", pp. 159-266, in: Epidemiology Applied to Health Physics, CONF-830101, DE-83014383, NTIS, Springfield, Virginia, 1983.
- Mo89 Morgan, M.G., and Henrion, M., Uncertainty: A Guide to Dealing with Uncertainty in Quantitative Risk and Policy Analysis, Cambridge University Press, 1989.
- NAS72 National Academy of Sciences - National Research Council, The Effects on Populations of Exposures to Low Levels of Ionizing Radiation, Report of the Committee on the Biological Effects of Ionizing Radiations (BEIR I Report), Washington, D.C., 1972.
- NAS80 National Academy of Sciences - National Research Council, The Effects on Populations of Exposure to Low Levels of Ionizing Radiation, Committee on the Biological Effects of Ionizing Radiation, (BEIR III), Washington, D.C., 1980.
- NAS88 National Academy of Sciences - National Research Council, Health Risks of Radon and Other Internally Deposited Alpha-Emitters, BEIR IV, National Academy Press, Washington, DC, 1988.

- NAS90 National Academy of Sciences - National Research Council, Health Effects of Exposure to Low Levels of Ionizing Radiation - BEIR V, National Academy Press, Washington, DC, 1990.
- NCHS73 National Center for Health Statistics, Public Use Tape, Vital Statistics - Mortality Cause of Death Summary - 1970, PB80-133333, Washington, D.C., 1973.
- NCHS75 National Center for Health Statistics, U.S. Decennial Life Tables for 1969-71, 1(1), DHEW Publication No. (HRA) 75-1150, U.S. Public Health Service, Rockville, Maryland, 1975.
- NCHS82 National Center for Health Statistics, Vital Statistics Mortality Data, Detail, 1979, PB82-132340, U.S. Department of Health and Human Services, Public Health Service, National Center for Health Statistics, Hyattsville, MD, 1982.
- NCHS83 National Center for Health Statistics, Vital Statistics Mortality Data, Detail, 1980, PB83-261545, U.S. Department of Health and Human Services, Public Health Service, National Center for Health Statistics, Hyattsville, MD, 1983.
- NCHS84 National Center for Health Statistics, Vital Statistics Mortality Data, Detail, 1981, PB84-213008, U.S. Department of Health and Human Services, Public Health Service, National Center for Health Statistics, Hyattsville, MD, 1984.
- NCHS85 National Center for Health Statistics, U.S. Decennial Life Tables for 1979-1981, Vol. 1 No. 1, United States Life Tables, (PHS) 85-1150-1, U.S. Department of Health and Human Services, Public Health Service, National Center for Health Statistics, Hyattsville, MD, August 1985.
- NCRP80 National Council on Radiation Protection and Measurements, Influence of Dose and Its Distribution in Time on Dose-Response Relationships for Low-LET Radiation, NCRP Report No. 64, Washington, D.C., 1980.
- NCRP85 National Council on Radiation Protection and Measurements, Induction of Thyroid Cancer by Ionizing Radiation, NCRP Report No. 80, Washington, D.C., 1985.
- NCRP90 National Council on Radiation Protection and Measurements, The Relative Biological Effectiveness of Radiations of Different Quality, NCRP Report No. 104, Washington, D.C., 1990.
- Pr87 Preston, D.L. and D.A. Pierce, The Effect of changes in Dosimetry on Cancer Mortality Risk Estimates in the Atomic Bomb Survivors. RERF 9-87, Radiation Effects Research Foundation, Hiroshima, 1987.
- Pr88 Preston, D.L. and D.A. Pierce, "The Effect of Changes in Dosimetry on Cancer Mortality Risk Estimates in the Atomic Bomb Survivors", Rad. Res. 114, 437-466, 1988.
- Pr93 Preston, D.L., D. Pierce, and M. Vaeth, "Neutrons and Radiation Risk: A Commentary", RERF Update 4(4), 5, 1993.
- Pu92 Puskin, J.S., "An Analysis of the Uncertainties in Estimates of Radon-Induced Lung Cancer," Risk Analysis, 12, 277-285, 1992.

- Sh84 Shore, R.E., E.D. Woodward, and L.H. Hempelman. Radiation Induced Thyroid Cancer. In: Radiation Carcinogenesis: Epidemiology and Biological Significance. pp 131-138, Raven Press, New York, 1984.
- Sh87 Shimizu, Y., Kato, H., Schull, W.J., Preston, D.L., Fujita, S. and Pierce, D.A., Life Span Study Report 11. Part I. Comparison of Risk Coefficients for Site-Specific Cancer Mortality Based on DS86 and T65DR Shielded Kerma and Organ Doses, RERF TR 12-87, Radiation Effects Research Foundation, Hiroshima, 1987. Also published as Rad. Res. 118, 502-524, 1989.
- Sh88 Shimizu, Y., Kato, H. and W.J. Schull, Life Span Study Report 11. Part 2. Cancer Mortality in the Years 1950-85 Based on the Recently Revised Doses (DS86), RERF TR 5-88, Radiation Effects Research Foundation, Hiroshima, 1988.
- Sh90 Shimizu, Y., H. Kato, and W.J. Schull, Studies of the mortality of A-bomb survivors: 9. Mortality, 1950-1985: Part 2. Cancer mortality based on the revised doses (DS86). Radiat. Res. 121: 120-141, 1990.
- Sj84 Sjoreen, A.L., Kocher, D.C., Killough, G.G., and Miller, C.W., MLSOIL and DFSOIL - Computer Codes to Estimate Effective Ground Surface Concentrations for Dose Computations, ORNL-5974, Oak Ridge National Laboratory, Oak Ridge, TN. November 1984. Corrections to the code were provided by A.L. Sjoreen for the calculations.
- Sm78 Smith, P.G. and R. Doll, "Radiation-Induced Cancers in Patients with Ankylosing Spondylitis Following a Single Course of X-ray Treatment", in: Proc. of the IAEA Symposium, Late Biological Effects of Ionizing Radiation, 1, 205-214, IAEA, Vienna, March 1978.
- St75 Storer, J.B., "Radiation Carcinogenesis," Cancer 1, pp. 453-483. F.F. Becker, editor, Plenum Press, New York, 1975.
- St88 Stather, J.W., C.R. Muirhead, A.A. Edwards, J.D. Harrison, D.C. Lloyd, and N.R. Wood. Health Effects Models Developed from the 1988 UNSCEAR Report. NRPB-R226. National Radiation Protection Board, Chilton, England, 1988.
- Su81 Sullivan, R.E., Nelson, N.S., Ellett, W.H., Dunning, D.E. Jr., Leggett, R.W., Yalcintas, M.G. and Eckerman, K.F., Estimates of Health Risk from Exposure to Radioactive Pollutants, Report No. ORNL/TM-7745, Oak Ridge National Laboratory, Oak Ridge, Tennessee, 1981.
- UI82 Ullrich, R.L., Lung Tumor Induction in Mice: Neutron RBE at Low Doses, NTIS-DE 82009642, National Technical Information Service, Springfield, Virginia, 1982.
- UI87 Ullrich, R.L., M.C. Jernigan, L.C. Satterfield, and N.D. Bowles, "Radiation Carcinogenesis: Time-Dose Relationships," Radiation Research, 111, 179-184, 1987.
- UNSC77 United Nations Scientific Committee on the Effects of Atomic Radiation, Sources and Effects of Ionizing Radiation, Report to the General Assembly, with Annexes, Sales No. E.77 IX.1., United Nations, New York, 1977.

- UNSC82 United Nations Scientific Committee on the Effects of Atomic Radiation, Ionizing Radiation: Sources and Biological Effects, 1982 Report to the General Assembly, Sales No. E.82. IX.8, United Nations, New York, 1982.
- UNSC88 United Nations Scientific Committee on the Effects of Atomic Radiation, Sources, Effects and Risks of Ionization Radiation, 1988 Report to the General Assembly, Sales No. #. 88. IX. 7, United Nations, New York, 1988.
- UNSC93 United Nations Scientific Committee on the Effects of Atomic Radiation, Sources, Effects and Risks of Ionizing Radiation, United Nations, NY, 1993.
- Wa83 Wakabayashi, T., et al., "Studies of the Mortality of A-Bomb Survivors, Report 7, Part III, Incidence of Cancer in 1959-1978, based on the Tumor Registry, Nagasaki," Radiat. Res. 93, 112-146, 1983.
- Wh83 Whittemore, A.S. and A. McMillan, A Lung Cancer Mortality Among U.S. Uranium Miners: A Reappraisal, Technical Report No. 68, SIAM Inst. Math. Soc., Stanford University, Stanford, 1983.

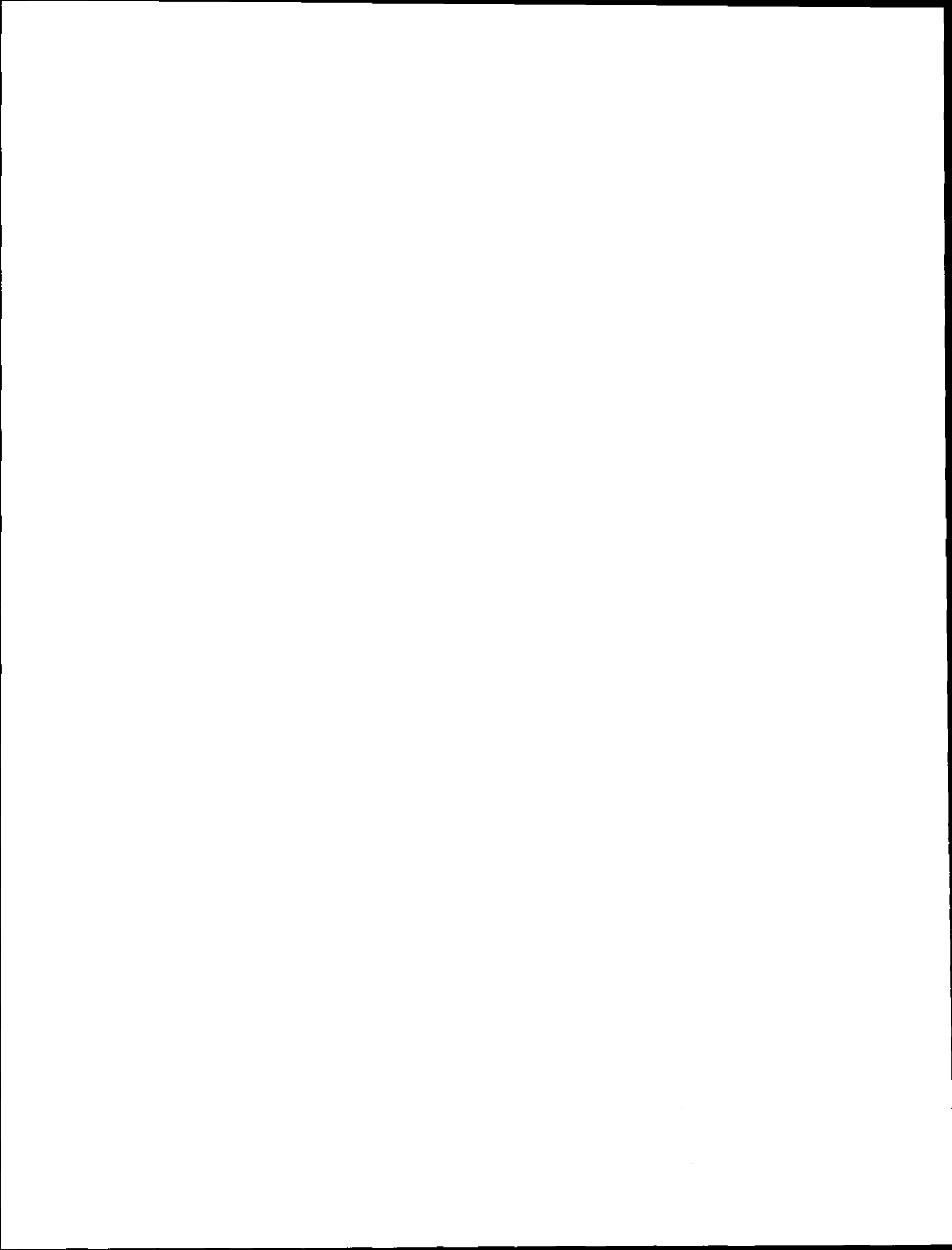

Appendix A

Radiation Dosimetry

[This page is blank intentionally.]

CONTENTS

Section	Page
A.1 INTRODUCTION	A-5
A.2 BASIC CONCEPTS	A-5
A.2.1 Activity	A-6
A.2.2 Radioactive Half-Life	A-6
A.2.3 Radionuclide Chains	A-7
A.2.4 Biological Half-Life	A-7
A.2.5 Internal and External Exposures to Radionuclides	A-7
A.2.6 Absorbed Dose and Absorbed Dose Rate	A-7
A.2.7 Linear Energy Transfer (LET)	A-8
A.2.8 Dose Equivalent and Dose Equivalent Rate	A-8
A.2.9 Effective Dose Equivalent and Effective Dose Equivalent Rate	A-9
A.2.10 Relationship of the Dose Equivalent and the Effective Dose Equivalent to Risk	A-10
A.2.11 Radon Decay-Product Units	A-11
A.2.12 Customary and SI Units	A-11
A.3 EPA DOSIMETRIC MODELS	A-11
A.3.1 Internal Dose Models	A-12
A.3.2 External Dose Models	A-21
A.5 REFERENCES	A-24

TABLES

Table		Page
A-1	Quality factor for various types of radiation	A-9
A-2	Tissue weighting factors recommended by the ICRP for stochastic risks	A-10
A-3	Comparison of Customary and SI Special Units for Radiation Quantities	A-12
A-4	Target organs and tissues considered in EPA dose calculations	A-13

FIGURES

Figure		Page
A-1	ICRP Lung Model	A-18
A-2	ICRP schematic representation of radioactivity movement among respiratory tract, gastrointestinal tract, and blood.	A-19

Appendix A

Radiation Dosimetry

Appendix A highlights the internal and external dosimetric models used by EPA to assess the dose to individuals exposed to radionuclides. Much of this information has been presented in detail elsewhere (EPA89, EPA93), and is discussed briefly here for the convenience of the reader. Special dosimetric methods for radon are presented elsewhere (EPA92) and are not discussed here.

A.1 INTRODUCTION

The evaluation of risks from environmental exposures to radionuclides requires an assessment of the doses received by individuals who are exposed by coming into contact with radiation sources. Two forms of potential radiation exposures can occur from these sources -- internal and external. Internal exposures can result from the inhalation of contaminated air or the ingestion of contaminated food or water. External exposures can occur when individuals are immersed in contaminated air or water or are standing on contaminated ground surfaces. Internal or external doses can result from either direct contact with the radiation from radionuclides at the site area or from radionuclides that have been transported from these sites to other locations in the environment. The quantification of the doses received by individuals from these radiation exposures is called radiation dosimetry.

The models for internal dosimetry consider the quantity of radionuclides entering the body, the factors affecting their movement or transport through the body, and the energy deposited in organs and tissues from the radiation that is emitted during spontaneous decay processes. The models for external dosimetry consider only the photon doses to organs of individuals who are immersed in air or are exposed to a contaminated ground surface. In addition, the uncertainties associated with each model will be discussed.

A.2 BASIC CONCEPTS

Radioactive materials produce radiation as their constituent radioactive nuclides undergo spontaneous radioactive decay. The forms of emitted energy are characteristic of the decay process and include energetic charged particles (alpha and beta particles) and photons (gamma rays and x-rays). Alpha particles are nuclei of helium atoms and carry two positive charges compared to electrons which carry a single negative charge. These particles can produce dense ionization tracks in the biological material that they traverse. Beta particles are electrons or positrons emitted in radioactive decay. Their penetration power in material is greater than that of alpha particles. Gamma and x-rays are electromagnetic radiation and, depending on energy, can have very great penetrating power in material.

$$D = \frac{d\bar{\epsilon}}{dm} = \lim_{\Delta m \rightarrow 0} \frac{\Delta\bar{\epsilon}}{\Delta m} \quad (\text{rad}) \quad (\text{A-6})$$

Internal and external exposures from radiation sources are not usually instantaneous but are distributed over extended periods of time. The resulting time rate of change of the absorbed dose to a small volume of mass is referred to as the absorbed dose rate, \dot{D}

$$\dot{D} = \frac{dD}{dt} = \lim_{\Delta t \rightarrow 0} \frac{\Delta D}{\Delta t} \quad (\text{mrad/y}) \quad (\text{A-7})$$

The customary unit of absorbed dose rate is any quotient of the rad (or its multiple or submultiple) and a suitable unit of time. In this report, absorbed dose rates are generally given in mrad/yr.

A.2.7 Linear Energy Transfer (LET)

The linear energy transfer, L_{∞} , is a quantity that represents the energy lost, by collision, per unit length by charged particles in an absorbing medium. It represents the increment of the mean energy lost, ΔE , to tissue by a charged particle of specified energy in traversing a distance, ΔX :

$$L_{\infty} = \frac{dE}{dX} = \lim_{\Delta x \rightarrow 0} \frac{\Delta E}{\Delta X} \quad (\text{keV mm}^{-1}) \quad (\text{A-8})$$

For photons, L_{∞} represents the energy imparted by the secondary electrons (electrons that are knocked out of their orbitals by primary radiation) resulting from secondary interactions between the photons and tissue material. High-LET radiation (alpha particles) imparts more energy per unit length of organ tissue than does low-LET radiation (x-rays, gamma rays, and beta particles). Consequently, the former are more effective per unit dose in causing biological damage.

A.2.8 Dose Equivalent and Dose Equivalent Rate

Dose equivalent is a special radiation protection quantity that is used to express the absorbed dose in a manner that considers the difference in biological effectiveness of various kinds of ionizing radiation. The ICRU has defined the dose equivalent, H , as the product of the absorbed dose, D , and the quality factor, Q , at the point of interest in biological tissue (ICRU80; an additional "modifying factor", N , is no longer used). This relationship can be expressed in the following manner:

$$H = D Q \quad (rem) \quad (A-9)$$

The quality factor is a dimensionless quantity that depends on the collision stopping power for charged particles, and it accounts for the differences in biological effectiveness found among varying types of radiation. By definition, it is independent of tissue and biological endpoint. The ICRP values for quality factors for high- and low-LET radiation, which are used by EPA, are given in Table A-1.

Table A-1. Quality factor for various types of radiation (ICRP77, ICRP91*)

Radiation Type	Quality Factor (Q)
x-rays, gamma rays, and electrons	1
alpha particles	20

* ICRP Publication 60 designates as "radiation weighting factors".

The dose equivalent rate, \dot{H} , is the time rate of change of the dose equivalent to organs and tissues and is expressed as:

$$\dot{H} = \frac{dH}{dt} = \lim_{\Delta t \rightarrow 0} \frac{\Delta H}{\Delta t} \quad (mrem/y) \quad (A-10)$$

A.2.9 Effective Dose Equivalent and Effective Dose Equivalent Rate

The ICRP has defined the effective dose equivalent, H_E , as:

$$H_E = \sum_T W_T H_T \quad (rem) \quad (A-11)$$

where H_T is the dose equivalent in tissue and w_T is the weighting factor, which represents the estimated proportion of the stochastic risk resulting from tissue, T, to the stochastic risk when the whole body is uniformly irradiated (ICRP77). The weighting factors recommended by the ICRP are listed in Table A-2.

More recently, ICRP (ICRP91) has adopted the use of effective dose, E, defined in a similar manner to H_E , but with a different set of tissue weighting factors, as shown in Table A-2. In addition to the revised tissue weighting factors, the tissue labeled "Remainder" is defined differently in the ICRP 30 and ICRP 60 methods.

Table A-2. Tissue weighting factors recommended by the ICRP for stochastic risks

ICRP Publication 26/30 (ICRP77,79)		ICRP Publication 60 (ICRP91)	
Organ or Tissue	W_T	Organ or Tissue	W_T
Gonads	0.25	Gonads	0.20
Breast	0.15	Red Bone Marrow	0.12
Red Bone Marrow	0.12	Colon	0.12
Lung	0.12	Lung	0.12
Thyroid	0.03	Stomach	0.12
Bone Surfaces	0.03	Bladder	0.05
Remainder	0.30	Breast	0.05
		Liver	0.05
		Esophagus	0.05
		Thyroid	0.05
		Skin	0.01
		Bone Surface	0.01
		Remainder	0.05

The effective dose equivalent rate is the time derivative of the dose equivalent and is expressed as \dot{H}_e , where

$$\dot{H}_e = \sum_T W_T \dot{H}_T \quad (\text{mrem/y}) \quad (\text{A-12})$$

A.2.10 Relationship of the Dose Equivalent and the Effective Dose Equivalent to Risk

The dose equivalent was formally defined by the International Commission on Radiation Units and Measurements (ICRU) in 1962. Using this construct, the biological effects of absorbed doses of different types of radiation can be compared for radiation protection purposes. Subsequently, the effective dose equivalent was introduced to provide a radiation protection quantity to compare detriment from dose equivalents distributed nonuniformly in the body. By convention, these concepts, in combination with the ICRP-recommended quality factors and organ-weighting factors, are widely used in radiation protection. These recommended factors, however, are based on models that differ significantly from those used to estimate risk.

To calculate risk, EPA first calculates age-specific, high- and low-LET absorbed dose rates, by organ, for a uniform intake or external exposure rate. The radiogenic risk associated with this dose is then calculated using the procedure described in Chapters 3 and 4 in conjunction with age- and organ-specific risk models.

These models assume a linear dose-response relationship and a lifetime relative risk projection for cancers other than bone, skin, and thyroid cancers, for which absolute risk projection is employed. These risks are integrated over the lifetime exposure period to arrive at the lifetime excess cancer risk.

In calculating dose equivalents and effective dose equivalents, the ICRP Publication 30 convention was employed, including the same quality factor and organ-weighting factors. However, in calculating the radiogenic cancer risk from a given absorbed dose of alpha particle irradiation, RBEs shown in Table B-1 were used. The ICRP organ-weighting factors shown in Table A-2 do not stand in the same proportion as the organ risks calculated using the EPA models for cancer induction or genetic mutations.

Furthermore, EPA considers somatic and genetic risks separately. Thus, even if attention is restricted to low-LET radiation, the EPA estimated risk from a given effective dose equivalent will vary, depending on how the absorbed dose is distributed within the body.

To summarize, because EPA risk models differ from those underlying the ICRP radiation protection recommendations, the effective dose equivalent derived using ICRP quality factor and organ weighting factors are not strictly proportional to risks calculated by the EPA.

A.2.11 Radon Decay-Product Units

The working level is a unit that has been used as a measure the radon decay-product activity in air. It is defined as any combination of short-lived radon daughters (through polonium-214) per liter of air that will result in the ultimate emission of 1.3×10^5 MeV of alpha energy. An activity concentration of 100 pCi/L of radon-222 in equilibrium with its short-lived daughters gives rise to a potential alpha-energy concentration of approximately 1 WL. Sometimes, the WL unit is also used for thoron (radon-220) daughters. The potential alpha energy exposure is commonly expressed in units of working level months (WLM). One WLM corresponds to an exposure to a concentration of 1 WL for the commonly used reference period of 170 hours.

A.2.12 Customary and SI Units

The relationship between the customary units used in this text and the international system of units (SI) for radiological quantities is shown in Table A-3. While the SI radiological units are almost universally used in other countries for radiation protection regulation, the United States has not yet officially adopted their use for such purposes.

A.3 EPA DOSIMETRIC MODELS

The EPA dosimetric models, to be discussed in the following sections, have been described in detail in previous publications (Du80, Su81, Ko81a, Ko81b). Information on the elements treated in these sections was taken directly from those documents or reports. In most cases, the EPA models are similar or identical to those recommended by the ICRP (ICRP79, ICRP80, ICRP81). [Differences in model parameters did exist for some

Table A-3. Comparison of Customary and SI Special Units for Radiation Quantities

Quantity	Customary Unit		Special SI Unit	
	Name	Definition	SI Unit	Definition
Activity (A)	Curie (Ci)	$3.7 \times 10^{10} \text{ s}^{-1}$	becquerel (Bq)	1.0 s^{-1}
Absorbed dose (D)	rad	$10^{-2} \text{ J kg}^{-1}$	gray (Gy)	1.0 J kg^{-1}
Dose equivalent (H)	rem	$10^{-2} \text{ J kg}^{-1}$	sievert (Sv)	1.0 J kg^{-1}
Linear energy transfer (L_{∞})	kiloelectron volts per micrometer ($\text{keV } \mu\text{m}^{-1}$)	$1.602 \times 10^{-10} \text{ J m}^{-1}$		

J = Joules; m = meter; s = seconds; kg = kilogram

radionuclides until 1983-1984 when EPA changed to the ICRP models for all radionuclides, except the transuranics.] The basic physiological and metabolic data used by EPA in calculating radiation doses are taken from ICRP reports (ICRP75, ICRP79).

A.3.1 Internal Dose Models

EPA implements contemporary models to estimate absorbed dose rates as a function of time to specified organs in the body. Estimates of the doses resulting from the deposition and retention of inhaled particulates in the lung and their subsequent absorption into the blood and clearance into the gastrointestinal (GI) tract are made using the ICRP Task Group Lung Model (ICRP66).

A.3.1.1 Generalized Scheme for Estimating Organ Absorbed Dose Rates

A.3.1.1.1 Distribution of Activity of Radionuclides in the Body. The complex behavior of radionuclides is simplified conceptually by considering the body as a set of compartments. A compartment may be any anatomical, physiological, or physical subdivision of the body throughout which the concentration of a radionuclide is assumed to be uniform at any given time. The terms "compartment" and "organ" are often used interchangeably, although some of the compartments considered in this report may represent only portions of a structure usually considered to be an organ, while some compartments may represent portions of the body usually not associated with organs. Examples of compartments used in this report are the stomach, the pulmonary region of the lung, the blood, or the bone. Within a compartment, there may be more than one "pool" of activity. A pool is defined to be any fraction of the activity within a compartment that has a

biological half-life which is distinguishable from the half-time(s) of the remainder of activity within the compartment.

Activity entering the body by ingestion is assumed to originate in the stomach compartment; activity entering through inhalation is assumed to originate in a compartment within the lung (the tracheo-bronchial, pulmonary, or naso-pharyngeal region). From the stomach, the activity is viewed as passing in series through the small intestine, the upper large intestine, and the lower large intestine, from which it may be excreted. Also, activity reaching the small intestine may be absorbed through the wall into the bloodstream, from which it may be taken in parallel into any of several compartments within the skeleton, liver, kidney, thyroid, and other organs and tissues.

The list of organs or regions for which dose rates are calculated is found in Table A-4. Activity in the lung may reach the bloodstream either directly or indirectly through the stomach or lymphatic system. The respiratory system and gastrointestinal tract models are discussed further in later sections.

Table A-4. Target organs and tissues considered in EPA dose calculations

Target Organ/Tissue
Lungs ^a
Stomach wall
Small intestine wall
Upper large intestine wall
Lower large intestine wall
Adrenals
Bladder Wall
Kidneys
Liver
Breast
Ovaries
Pancreas ^b
Brain
Red Bone Marrow
Endosteum (Bone Surface)
Skin
Spleen
Testes
Thymus
Thyroid
Uterus

^a Since 1983, doses are also computed for three separate lung regions (naso-pharyngeal region, tracheo-bronchial region, and pulmonary region) for inhalation exposures, plus intestinal wall, other, remainder, gonads, and effective.

^b The pancreas is also used as a surrogate organ for calculating the cancer risk for all other organs and tissues.

EPA models separately consider the intake and subsequent behavior of each radionuclide in the body. The models also allow for the formation of radioactive decay products within the body, and it is assumed that the movement of internally produced radioactive daughters is governed by their own metabolic properties rather than those of the parent. This is in contrast to the ICRP assumption that daughters behave exactly as the parent.

If $A_{ik}(t)$ denotes the activity of the i th species of the chain in organ k and if that activity is divided among several "pools" or "compartments" indexed by subscript l , then the time rate of change of activity can be modeled by a system of differential equations of the following form:

$$A_{ilk} = -(\lambda_i^R + \lambda_{ilk}^B)A_{ilk} + C_{ilk}(\lambda_i^R \sum_{j=1}^{L_{ik}} B_{ij} \sum_{r=1}^{L_{jk}} A_{jr} + P_{ik}^{L_{jk}}) \quad (A-13)$$

$$l = 1, \dots, L_{ik}$$

where compartment l is assumed to have L_{ik} separate pools of activity, and where

- A_{ilk} = the activity of species i in compartment l of organ k ;
- λ_i^R = $(\ln 2) / T_i^R$, where T_i^R = radioactive half of species i ;
- λ_{ilk}^B = rate coefficient (time^{-1}) for biological removal of species i from compartment l of organ k ;
- L_{ik} = number of exponential terms in the retention function for species i in organ k ;
- B_{ij} = branching ratio of nuclide j to species i ;
- P_{ik} = inflow rate of the i^{th} species onto the organ k ; and
- C_{ik} = the fractional coefficient for nuclide i in the l^{th} compartment of organ k .

The subsystem described by these L_{ik} equations can be interpreted as a biological compartment in which the fractional retention of radioactive species is governed by exponential decay. Radioactivity that enters an organ may be lost by both radioactive decay and biological removal processes. For each source organ, the fraction of the initial activity remaining at any time after uptake at time $t = 0$ is described by a retention function consisting of one or more exponentially decaying terms:

$$R_{ik}(t) = \sum_{l=1}^{L_{ik}} C_{ilk} \exp[-(\lambda_i^R + \lambda_{ilk}^B)t] \quad (A-14)$$

The subscript l in the above equation represents the l^{th} term of the retention function, and the coefficients c_{ilk} can be considered as "pathway fractions."

A.3.1.1.2 Dose Rates to Target Organs. The activity of a radionuclide in a compartment is a measure of the rate of energy being emitted in that compartment, at any time, t , and can be related to the dose rate to a specific organ at that time. This requires estimating the fraction of the energy emitted by the decay of the radionuclide in each compartment that is absorbed by the specific organ.

The absorbed dose rate, $\dot{D}_i(X;t)$ to target organ X at time t due to radionuclide species i in source organs Y_1, Y_2, \dots, Y_M is estimated by the following equation:

$$\dot{D}_i(X;T) = \sum_{k=1}^M D_i(X-Y_k;t) \quad (\text{A-15})$$

where

$$\begin{aligned} \dot{D}_i(X-Y_k;t) &= S_i(X-Y_k) A_{ik}(t); \text{ and} \\ A_{ik}(t) &= \text{activity, at time } t \text{ of species } i \text{ in source organ } Y_k. \end{aligned}$$

$S_i(X-Y_k)$, called the S-factor, represents the average dose rate to target organ X from one unit of activity of the radionuclide uniformly distributed in source organ or compartment Y_k (Sn74). It is expressed in the following manner:

$$S_i(X-Y_k) = c \sum_m f_m E_m \Phi_m(X-Y_k) \quad (\text{A-16})$$

where

$$\begin{aligned} c &= \text{a constant that depends on the units of dose, energy, and time being used;} \\ f_m &= \text{intensity of decay event (number per disintegration);} \\ E_m &= \text{average energy of decay event (Mev); and} \\ \Phi_m(X-Y_k) &= \text{specific absorbed fraction, i.e., the fraction emitted energy from source organ } Y_k \\ &\quad \text{absorbed by target organ } X \text{ per gram of } X, \text{ where the summation is taken over all} \\ &\quad \text{events of type } m. \end{aligned}$$

The units for S-factors depend on the units used for activity and time; thus, the S-factor units may be rad/Ci-day. The S-factor is similar in concept to the SEE factor (specific effective energy) used by the ICRP Committee 2 in Publication 30 (ICRP79). However, the SEE factor includes a quality factor for the type of radiation emitted during the transformation.

The above equations are combined to produce the following expressions for the absorbed dose rates to target organs at any time due to one unit of activity of radionuclide species, i , uniformly distributed in source organs $Y_1 \dots Y_k$:

$$\dot{D}(X;t) = \sum_k \sum_m A_{ik}(t) S_{im}(X-Y_k) \quad (\text{A-17})$$

The corresponding dose equivalent rate, $\dot{H}_f(X;t)$, can be estimated by inclusion of the quality factor, Q_m :

$$\dot{H}_f(X;t) = \sum_k \sum_m A_{ik}(t) Q_m S_{im}(X-Y_k) \quad (\text{A-18})$$

Implicit in the above equations is the assumption that the absorbed dose rate to an organ is determined by averaging absorbed dose distributions over its entire mass.

Alpha and beta particles are usually not sufficiently energetic to contribute a significant cross-irradiation dose to targets separate from the source organ. Thus, the absorbed fraction for these radiations is generally assumed to be just the inverse of the mass of organ X, or if the source and target are separated, then $\phi_m(X-Y) = 0$. Exceptions occur when the source and target are in very close proximity, as is the case with various skeletal tissues. Absorbed fractions for cross-irradiations by beta particles among skeletal tissues were taken from ICRP Publication 30 (ICRP80). The energy of alpha particles and their associated recoil nuclei is generally assumed to be absorbed in the source organ. Therefore, $\phi_m(X-X)$ is taken to be the inverse of the organ mass, and $\phi_m(X-Y) = 0$ if X and Y are separated. Special calculations are performed for active marrow and endosteal cells in bone, based on the method of Thorne (Th77).

A.3.1.1.3 Monte Carlo Methodology to Estimate Photon Doses to Organs. The Monte Carlo method uses a computerized approach to estimate the probability of photons interacting within target organ X after emission from source organ Y. The method is carried out for all combinations of source and target organs and for several photon energies. The body is represented by an idealized phantom in which the internal organs are assigned masses, shapes, positions, and attenuation coefficients based on their chemical composition. A mass attenuation coefficient, μ_o , is chosen, where μ_o is greater than or equal to the mass attenuation coefficients for any region of the body. Photon courses are simulated in randomly chosen directions, and potential sites of interactions are selected by taking distances traversed by them as $-\ln r/\mu_o$, where r is a random number distributed between 0 and 1. The process is terminated when either the total energy of photons has been deposited or the photon escapes from the body. The energy deposition for an interaction is determined according to standard equations (Sn74).

A.3.1.1.4 Effects of Decay Products. In calculating doses from internal and external exposures, the in-growth of radioactive decay products (or daughters) must be considered for some radionuclides. When an atom undergoes radioactive decay, the new atom created in the process, which may also be radioactive, can contribute to the radiation dose to organs or tissues in the body. Although these decay products may be treated

as independent radionuclides in external exposure, the decay products of each parent must be followed through the body in internal exposure situations. The decay product contributions to the absorbed dose rates, which are included in EPA calculations, are based on the metabolic properties of the individual daughters and the organ in which they occur.

A.3.1.2 Inhalation Dosimetry - ICRP Respiratory Tract Model. As stated earlier, individuals immersed in contaminated air will breathe radioactive aerosols or particulates, which can lead to doses to the lung and other organs in the body. The total internal dose caused by inhalation of these aerosols can depend on a variety of factors, such as breathing rates, particle sizes, and physical activity. Estimating the total dose to individuals over a specific time period requires specifying the distribution of particle depositions in the respiratory tract and the mathematical characteristics of the clearance parameters. The EPA currently uses assumptions established by the ICRP Task Group on Lung Dynamics (TGLM)(ICRP66). This section will summarize the essential features of that model. For a more comprehensive treatment, the reader is referred to the actual report.

The basic features of the ICRP lung compartmental model are shown in Figure A-1. According to this model, the respiratory tract is divided into four regions: naso-pharyngeal (N-P), tracheo-bronchial (T-B), pulmonary (P), and lymphatic tissues. In the model, the regions N-P, T-B, and P are assumed to receive fractions D_3 , D_4 , and D_5 of the inhaled particulates, where the sum of these is less than 1 (some particles are removed by prompt exhalation). The values D_3 , D_4 , and D_5 depend on the activity median aerodynamic diameter (AMAD) of the inspired particles. For purposes of risk calculations, EPA uses a default AMAD value of 1 micron. The lung model employs three clearance classes, D, W, and Y, corresponding to rapid, intermediate, and slow clearance, respectively, of material deposited in the respiratory passages. The clearance class depends on chemical properties of the inhaled particles.

Like the ICRP, EPA assumes that the absorbed dose rate to the N-P region can be neglected. Unlike the ICRP, however, EPA averages the dose over the pulmonary region of the lung (compartments e through h), to which is assigned a mass of 570 g, including capillary blood (ICRP75). In addition, it is assumed that the total volume of air breathed in one day by a typical member of the general population is 22,000 liters. This value was determined by averaging the ICRP Publication 23 adult male and female values based on 8 hours of working "light activity," 8 hours of nonoccupational activity, and 8 hours of resting.

A.3.1.3 Ingestion Dosimetry - ICRP GI Tract Model. According to the ICRP 30 GI tract model, the gastrointestinal tract consists of four compartments: the stomach (S), small intestine (SI), upper large intestine (ULI), and lower large intestine (LLI). The fundamental features of the model are shown in Figure A-2. It is assumed that absorption into the blood occurs only from the small intestine (SI).

Figure A-1. The ICRP Task Group lung model for particulates.

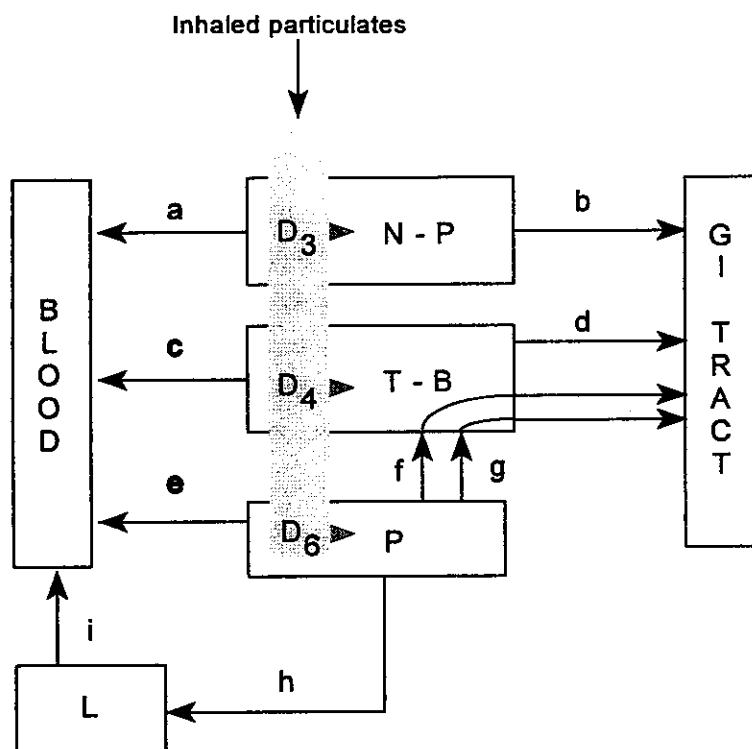

COMPARTMENT		CLASS					
		D		W		Y	
		T	F	T	F	T	F
N - P (D ₃ - 0.030)	a	0.01	0.5	0.01	0.1	0.01	0.01
	b	0.01	0.5	0.4	0.9	0.4	0.99
T - B (D ₄ - 0.08)	c	0.01	0.95	0.01	0.5	0.01	0.01
	d	0.2	0.05	0.2	0.5	0.2	0.99
P (D ₅ - 0.25)	e	0.5	0.8	50	0.15	500	0.05
	f	n.a.	n.a.	1.0	0.4	1.0	0.4
	g	n.a.	n.a.	50	0.4	500	0.4
	h	0.5	0.2	50	0.05	500	0.15
L	i	0.5	1.0	50	1.0	1000	0.9

Compartments: N - P = nasopharyngeal; T - B = tracheobronchial; P = pulmonary; L = lymphatic. The columns labeled D, W, and Y correspond, respectively, to rapid, intermediate, and slow clearance of the inspired material (in days, weeks, or years). The symbols T and F denote the biological half-times (days) and coefficient, respectively, of a term in the appropriate retention function. The values for D₃, D₄, and D₅ correspond to activity median aerodynamic diameter, AMAD = 1 μm, and represent the fraction of the inspired material depositing in the lung regions.

Figure A-2. ICRP schematic representation of radioactivity movement among the respiratory tract, gastrointestinal tract, and blood.

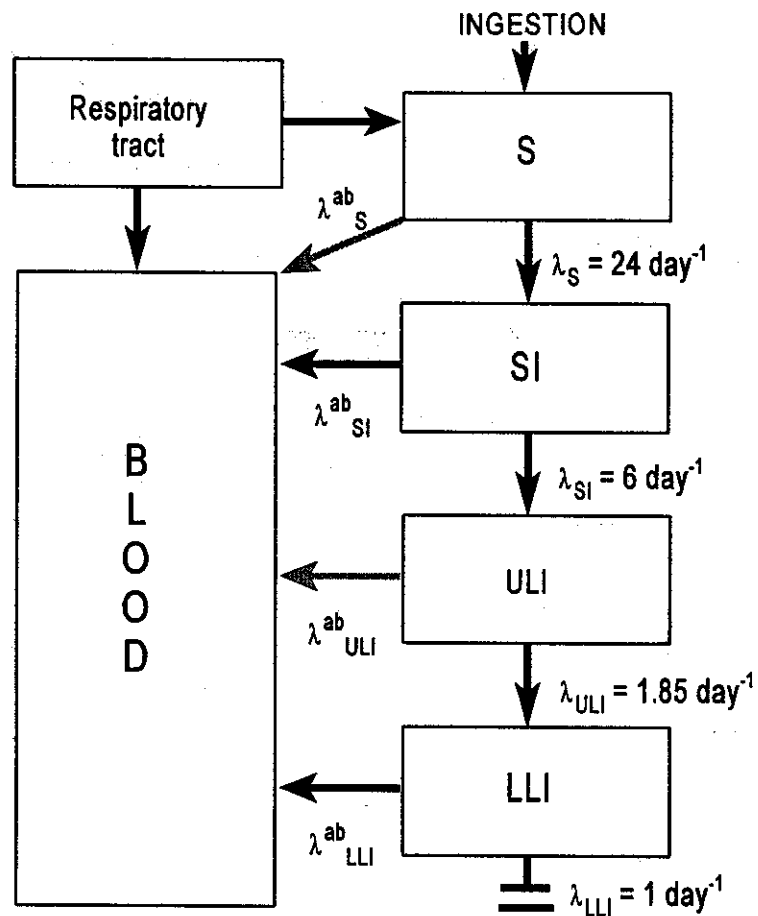

S = stomach
 SI = small intestine
 ULI = upper large intestine
 LLI = lower large intestine
 λ = elimination rate constant

This model postulates that radioactive material entering the compartments of the GI tract is exponentially removed by both radioactive decay and biological removal processes, and that there is no feedback. Absorption of a particular nuclide from the GI tract is characterized by f_i , which represents that fraction of the nuclide ingested which is absorbed into body fluids if no radiological decay occurs, where

$$f_1 = \frac{\lambda_{SI}^{ab}}{(\lambda_{SI}^{ab} + \lambda_{SI})} \quad (\text{A-19})$$

λ_{SI}^{ab} = the absorption coefficient (s^{-1})

λ_{SI} = the transfer coefficient from the small intestine to the large intestine (s^{-1})

Figure A-1 graphically presents the role of these coefficients in the gastrointestinal model. The kinetic model, as formulated by the ICRP, does not permit total absorption of a nuclide ($f_1 = 1$). (The maximum value used in EPA's calculations is $f_1 = 0.95$.)

A.3.1.4 Dose Rate Conversion Factors. EPA uses the computer code RADRISK (Du80) for calculating age-specific radiation dose rates resulting from a chronic unit intake rate of a radionuclide for a lifetime exposure. These calculations are performed for inhalation and ingestion exposure pathways.

Following the beginning of chronic exposure, the activity in each organ of the body increases monotonically until a steady state is achieved, at which time the activity remains constant. The instantaneous dose rates at various times after the start of chronic exposure provide a reasonably accurate (and conservative) estimate of the total annual dose for chronic exposure conditions. Since the rate of change in activity levels in various organs is more rapid at early times after exposure, annual dose rates for use in risk calculations are averaged over progressively longer periods.

A.3.1.5 Special Radionuclides

Tritium and Carbon-14 Most radionuclides are nuclides of elements found only in trace quantities in the body. Others like tritium (hydrogen-3) or carbon-14 must be treated differently since they are long-lived nuclides of elements that are ubiquitous in tissue. An intake of tritium is assumed to be completely absorbed and to be rapidly mixed with the water content of the body (Ki78a).

The estimates for inhalation include consideration of absorption through the skin. Organ dose estimates are based on the steady-state specific-activity model described by Killough et al. (Ki78a).

Carbon-14 is assumed to be inhaled as CO_2 or ingested in a biologically bound form. Inhaled carbon-14 is assumed to be diluted by stable carbon from ingestion (Ki78b). This approach allows separate consideration of the ingestion and inhalation pathways. The specific-activity model used for organ dose estimates is also that of Killough et al. (Ki78a). Short-lived carbon radionuclides (e.g., carbon-11 or carbon-15) are treated as trace elements, and the organ doses are calculated accordingly.

Radon Decay Products EPA estimates radiogenic cancer risk resulting from inhalation of radon decay products based on an epidemiological, based on human epidemiological data. In this approach, the airborne concentration, expressed in WL (see A.2.11), and exposure duration are used in conjunction with a corresponding risk factor (risk per WLM), and absorbed dose rates or dose equivalent rates are not computed.

A.3.2 External Dose Models

This section is concerned with the calculation of dose rates for external exposure to photons from radionuclides dispersed in the environment. Two exposure models are discussed: (1) immersion in contaminated air and (2) irradiation from material deposited on the ground surface. The immersion source is considered to be a uniform semi-infinite radionuclide concentration in air, while the ground surface irradiation source is viewed as a uniform radionuclide concentration on an infinite plane. In both exposure modes, the dose rates to organs are calculated from the dose rate in air.

Dose rates are calculated as the product of a dose rate factor, which is specific for each radionuclide, tissue, and exposure mode, and the corresponding air or surface concentration. The dose rate factors used were calculated with the DOSFACTOR code (Ko81a,b). Note that the dose rate factors for each radionuclide do not include any contribution for decay products. For example, the ground surface dose factors for cesium-137 are all zero, since no photons are emitted in its decay. To assess surface deposition of cesium-137, the ingrowth of its decay product, metastable barium-137, which is a photon emitter, must first be calculated.

A.3.2.1 Immersion. For immersion exposure to the photons from radionuclides in air, EPA assumes that an individual is standing at the base of a semi-infinite cloud of uniform radionuclide concentration. First, the dose rate factor (the dose rate for a unit concentration) in air is calculated for a source of photons with energy E_γ . At all points in an infinite uniform source, conservation of energy considerations require that the rates of absorbed and emitted energy per unit mass be equal. The absorbed energy rate per unit mass at the boundary of a semi-infinite cloud is one-half that value. For a photon of energy E_γ ,

$$D_\gamma^a(E_\gamma) = \frac{1}{2} k \frac{E_\gamma}{\rho} \quad (\text{A-20})$$

where

$D_\gamma^a(E_\gamma)$	=	the dose rate per in air from immersion in a unit air concentration (rad-m ³ /Ci-s);
E_γ	=	emitted photon energy (MeV);
k	=	units conversion factor
	=	1.62E-13 (J/MeV) x 3.7E+10 (dis/s-Ci) x 1.0E+3 (g/kg) x 100 (rad kg/J)
	=	5.93E+2 (rad-g/MeV-Ci-s) [or 1.602E-10 Gy-g/MeV-Bq-s]; and
ρ	=	density of air (g/m ³).

The above equation presumes that for each nuclide transformation, one photon with energy E_γ is emitted. The dose rate factor for a nuclide is obtained by adding together the contributions from each photon associated with the transformation process for that radionuclide.

A.3.2.2 Ground Surface Irradiation. In the case of air immersion, the radiation field was the same throughout the source region. This allows the dose rate factor to be calculated on the basis of energy conservation without having to consider explicitly the scattering processes taking place. For ground surface irradiation, the radiation field depends on the height of the receptor above the surface, and the dose rate factor calculation is more complicated. The radiation flux per unit solid angle is strongly dependent on the angle of incidence. It increases from the value for photons incident from immediately below the receptor to a maximum close to the horizon. Attenuation and buildup due to scattering must be considered to calculate the dose rate factor. Secondary scattering provides a distribution of photon energies at the receptor, which increases the radiation flux above that calculated on the basis of attenuation. Trubey (Tr66) has provided a useful and reasonably accurate expression to approximate this buildup:

$$B_{en}^a(\mu_a r) = 1 + C_a \mu_a r \exp(D_a \mu_a r) \quad (A-21)$$

where

- B_{en}^a = the buildup factor (i.e., the quotient of the total energy flux and that calculated for attenuation) for energy in air;
- μ_a = attenuation coefficient at the energy of the released photon (m^{-1});
- r = distance between the photon source and the receptor; and
- C_a, D_a = Berger buildup coefficients in air, which are dependent on energy and the scattering medium.

The buildup factor is dimensionless and always has a value greater than unity. The resulting expression for the dose rate factor at a height z (m) above a uniform plane is

$$D_\gamma^s(E_\gamma, z) = \frac{1}{2} k E_\gamma \left(\frac{\mu_{en}}{\rho}\right)_a [E_1(\mu_a z) + \frac{C_a}{(1-D_a)} \exp(-(1-D_a)\mu_a z)] \quad (A-22)$$

where

- $D_\gamma^s(E_\gamma, z)$ = dose rate in air per unit exposure ($rad\cdot m^3/Ci\cdot s$) to a uniform surface concentration;
- z = reference height above the ground surface (1 m);
- $(\mu_{en}/\rho)_a$ = the mass energy-absorption coefficient (m^2/g) in air at E_γ ; and
- E_1 = the first order exponential integral function, i.e.,

$$E_1(x) = \int_0^{\infty} \frac{\exp(-u) du}{u} \quad (\text{A-23})$$

The dose rate at a height, z , above a soil volume uniformly contaminated with a radionuclide emitting monoenergetic photons of energy E_γ is computed as (Sj84):

$$D_\gamma^v(E_\gamma, x_a) = \frac{1}{2} k E_\gamma \left(\frac{\mu_{en}}{\rho}\right)_a \frac{1}{\mu_s} [E_2(\mu_s x_a) + \frac{C_s}{(1-D_s)^2} \exp(-(1-D_s)\mu_s x_a)] \quad (\text{A-24})$$

where

$D_\gamma^v(E_\gamma, x_a)$	=	the dose rate in air per unit exposure to a uniform volume concentration in soil (rad-m ³ /Ci-s);
x_a	=	thickness of soil corresponding to 100 cm of air;
$(\mu_{en}/\rho)_s$	=	the mass energy-absorption coefficient (m ² /g) in soil;
C_s, D_s	=	Berger energy buildup coefficients in soil at energy E_γ ; and
E_2	=	the second order exponential integral function.

The thickness of soil corresponding to 100 cm of air, x_a , is calculated as the depth for which the dose at the soil surface from a plane source has the same value as $D_\gamma^s(E_\gamma, z)$ from Eqn A-22. For $z=100$ cm, the values of x_a are in the range of about 0.01 to 0.08 mm.

The dose factor for a given radionuclide is computed as the sum over all its characteristic photon releases of the product of the corresponding energy-specific dose factor and intensity. The effective depth, x_e , for each radionuclide is computed as the ratio of the volume dose factor to the surface dose factor (D^v/D^s). This radionuclide-specific estimate of the effective depth is used by EPA in conjunction with the surface dose rate factors to estimate the dose and risk from external exposure to radionuclides in soil, as discussed in Section 2.2.2.2.

A.3.2.3 Organ Doses. The dose rate factors in the preceding two sections are for the absorbed dose in air. For estimating health risks, the absorbed doses in specific tissues and organs are needed. For this purpose, Kerr and Eckerman (Ke80a,b) have calculated organ dose factors for immersion in contaminated air. Their calculations are based on Monte Carlo simulations of the absorbed dose in each tissue or organ for the spectrum of scattered photons in air resulting from a uniform concentration of monoenergetic photon sources. Kocher (Ko81a,b) has used these data to calculate values of the ratio of the organ dose factor to the air dose factor, $G^k(E_\gamma)$, for 24 organs/tissues at 15 values of E_γ ranging from 0.01 to 10 MeV.

The dose rate factor for organ k, D_{γ}^k , from immersion in contaminated air is

$$D_{\gamma}^k(E_{\gamma}) = G^k(E_{\gamma}) D_{\gamma}^a(E_{\gamma}) \quad (\text{A-25})$$

For a given nuclide, the dose rate factor is obtained by taking the sum of the contributions from each photon energy associated with the radionuclide decay. Ideally, a separate set of $G^k(E_{\gamma})$ values would be used for the angular and spectral distributions of incident photons from a uniform plane source. Since these data are not available, Kocher has used the same set of $G^k(E_{\gamma})$ values for calculating organ dose rate factors for both types of exposure (Ko81a,b).

A.5 REFERENCES

- Du80 Dunning, D.E. Jr., Leggett, R.W., and Yalcintas, M.G., "A Combined Methodology for Estimating Dose Rates and Health Effects from Exposure to Radioactive Pollutants," ORNL/TM-7105, 1980.
- EPA89 U.S. Environmental Protection Agency, "Environmental Impact Statement, NESHAPS for Radionuclides, Background Information Document - Volume 1, Risk Assessment Methodology," EPA/520/1-89-005, September 1989.
- EPA92 U.S. Environmental Protection Agency, "Technical Support Document for the 1992 Citizens Guide to Radon," EPA 400-R-92-011, May 1992.
- EPA93 U.S. Environmental Protection Agency, "High-Level and Transuranic Radioactive Wastes, Background Information Document for Proposed Amendments," EPA 400-R-93-007, January 1993.
- ICRP66 ICRP Task Group on Lung Dynamics, "Depositions and Retention Models for Internal Dosimetry of the Human Respiratory Tract," Health Phys., 12(2):173-207, 1966.
- ICRP75 International Commission on Radiological Protection, Report on the Task Group on Reference Man, ICRP Publication No. 23, Pergamon Press, Oxford, 1975.
- ICRP77 International Commission on Radiological Protection, "Recommendations of the International Commission on Radiological Protection," ICRP Publication 26, Annals of the ICRP, Vol. 1, No. 3, Pergamon Press, Oxford, 1977.
- ICRP79 International Commission on Radiological Protection, "Limits for Intakes of Radionuclides by Workers," ICRP Publication No. 30, Pergamon Press, Oxford, 1979.
- ICRP80 International Commission on Radiological Protection, "Limits for Intakes of Radionuclides by Workers," ICRP Publication 30, Part 2, Annals of the ICRP, Vol. 4 (3/4), Pergamon Press, Oxford, 1980.
- ICRP81 International Commission on Radiological Protection, "Limits for Intakes of Radionuclides by Workers," ICRP Publication 30, Part 3, Annals of the ICRP, Vol. 6 (2/3), Pergamon Press, Oxford, 1981.

- ICRP84 International Commission on Radiological Protection, "A Compilation of the Major Concepts and Quantities in Use by ICRP," ICRP Publication No. 42, Pergamon Press, Oxford, 1984.
- ICRP91 International Commission on Radiological Protection, "1990 Recommendations of the International Commission on Radiological Protection," ICRP Publication No. 60, Annals of the ICRP, 21 (1-3), Pergamon Press, Oxford, 1991.
- ICRU80 International Commission on Radiation Units and Measurements, ICRU Report No 33, Washington, D.C., 1980.
- Ke80a Kerr, G.D., and Eckerman, K.F., Oak Ridge National Laboratory, private communication; see also Abstract P/192 presented at the Annual Meeting of the Health Physics Society, Seattle, Washington, July 20-25, 1980.
- Ke80b Kerr, G.D., "A Review of Organ Doses from Isotropic Fields of X-Rays," Health Phys., 39(1):3, 1980.
- Ki78a Killough, G.C., Dunning, D.E Jr., Bernard, S.R. and Pleasant, J.C., Estimates of Internal Dose Equivalent to 22 Target Organs for Radionuclides Occurring in Routine Releases from Nuclear Fuel Cycle Facilities, Vol. 1, Report No. ORNL/NUREG/TM-190, Oak Ridge National Laboratory, Tennessee, June 1978.
- Ki78b Killough, G.C., and Rohwer, P.S., "A New Look at the Dosimetry of ^{14}C Released to the Atmosphere as Carbon Dioxide," Health Phys., 34(2):141, 1978.
- Ko81a Kocher, D.C., "Dose-Rate Conversion Factors for External Exposure to Photons and Electrons," NUREG/CR-1918, ORNL/NUREG-79, Oak Ridge National Laboratory, Oak Ridge, TN, 1981.
- Ko81b Kocher, D.C., "Dose-Rate Conversion Factors for External Exposure to Photon and Electron Radiation from Radionuclides Occurring in Routine Releases from Nuclear Fuel-Cycle Facilities," Health Phys., 38(4):543-621, 1981.
- NCRP71 National Council on Radiation Protection and Measurements, Basic Radiation Protection Criteria, NCRP Report No. 39, Washington, D.C., 1971.
- Sn74 Snyder W.S., Ford, M.R., Warner, G.G., and Watson, S.B., A Tabulation of Dose Equivalent per Microcurie-Day for Source and Target Organs of an Adult for Various Radionuclides, Oak Ridge National Laboratory, ORNL-5000, 1974.
- Su81 Sullivan, R.E., Nelson, N.S., Ellett, W.H., Dunning, D.E. Jr., Leggett, R.W., Yalcintas, M.G. and Eckerman, K.F., Estimates of Health Risk from Exposure to Radioactive Pollutants, Report No. ORNL/TM-7745, Oak Ridge National Laboratory, Oak Ridge, Tennessee, 1981.
- Th77 Thorne, M.D., "Aspects of the Dosimetry of Alpha-Emitting Radionuclides in Bone with Particular Emphasis on ^{226}Ra and ^{239}Pu ," Phys. Med. Biol., 22:36-46, 1977.
- Tr66 Trubey, D.K., A Survey of Empirical Functions Used to Fit Gamma-Ray Buildup Factors, Oak Ridge National Laboratory Rep., ORNL-RSIC-10, 1966.

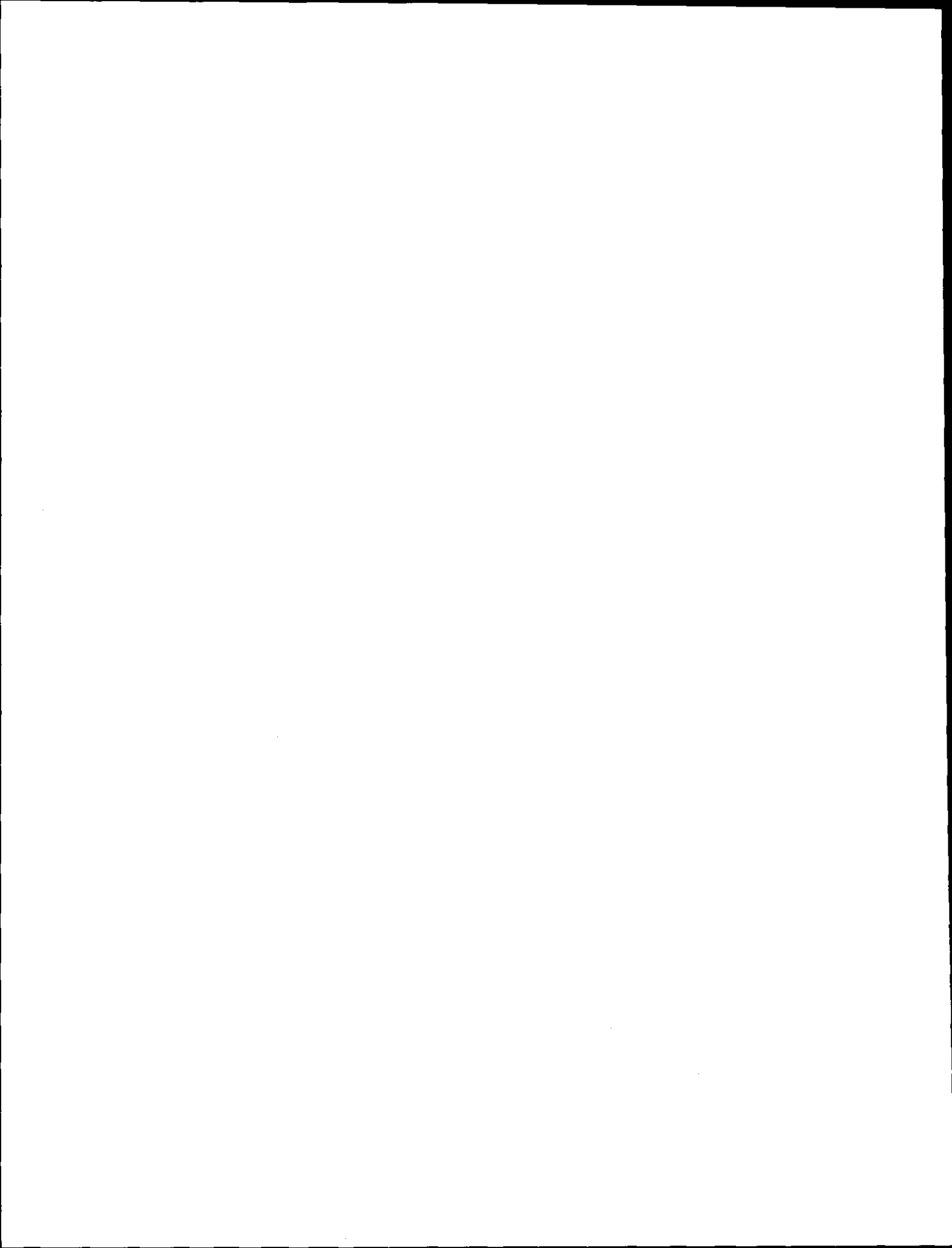

Appendix B

Attributable Mortality Risk Coefficients

CONTENTS

Section	Page
B	Attributable Mortality Risk Coefficients B-3

TABLES

Table	Page
B-1	Risk Models, DDREFs, RBEs and Lethality Fractions Assumed by EPA for Specific Cancer Sites for Radiation Risk Assessment B-4
B-2	Attributable Mortality Risk Coefficients: Esophagus (DDREF=2)(Sv ⁻¹) B-5
B-3	Attributable Mortality Risk Coefficients: Stomach (DDREF=2)(Sv ⁻¹) B-6
B-4	Attributable Mortality Risk Coefficients: Colon (DDREF=2)(Sv ⁻¹) B-7
B-5	Attributable Mortality Risk Coefficients: Liver (DDREF=2)(Sv ⁻¹) B-8
B-6	Attributable Mortality Risk Coefficients: Lung (DDREF=2)(Sv ⁻¹) B-9
B-7	Attributable Mortality Risk Coefficients: Bone (DDREF=2)(Sv ⁻¹) B-10
B-8	Attributable Mortality Risk Coefficients: Skin (DDREF=2)(Sv ⁻¹) B-11
B-9	Attributable Mortality Risk Coefficients: Breast (DDREF=1)(Sv ⁻¹) B-12
B-10	Attributable Mortality Risk Coefficients: Ovary (DDREF=2)(Sv ⁻¹) B-13
B-11	Attributable Mortality Risk Coefficients: Bladder (DDREF=2)(Sv ⁻¹) B-14
B-12	Attributable Mortality Risk Coefficients: Kidney (DDREF=2)(Sv ⁻¹) B-15
B-13	Attributable Mortality Risk Coefficients: Thyroid (DDREF=2)(Sv ⁻¹) B-16
B-14	Attributable Mortality Risk Coefficients: Leukemia (DDREF=2)(Sv ⁻¹) B-17
B-15	Attributable Mortality Risk Coefficients: Residual (DDREF=2)(Sv ⁻¹) B-18
B-16	Attributable Mortality Risk Coefficients: All Cancers (Sv ⁻¹) B-19
B-17	Attributable Mortality Risk Coefficients: Radon Daughter Inhalation (WL ⁻¹) B-20

Appendix B

Attributable Mortality Risk Coefficients

Appendix B presents attributable mortality risk coefficients for EPA's revised radiation risk assessment methodology. In addition to the individual cancer sites considered in the revised risk methodology, risk coefficients are also tabulated for all cancers combined and the special case of radon daughter inhalation. Absolute risk models are employed for bone, skin, and thyroid cancer. Relative risk models are used for all other cancer sites. Corresponding values for attributable cancer incidence risk coefficients may be derived by dividing these values by the appropriate lethality fraction (see below). The baseline mortality data used to derive these risk coefficients (for the relative risk models) are those of the 1980 decennial U.S. population (1979-1981). For each cancer site considered, risk coefficients are tabulated for each age at exposure, T_e , for males, females, and the general population (based on male:female birth ratio of 1.051).

The risk coefficients presented in the following tables are applicable to low-LET radiation. Corresponding risk coefficients for high-LET radiation may be derived by multiplying these values by the appropriate relative biological effectiveness (RBE): 1 for leukemia, 10 for breast, and 20 for all other cancer sites. Furthermore, these risk coefficients are applicable to low dose and low dose rate exposure conditions [<0.2 Gy (<20 rad)]. The dose and dose rate effectiveness factors (DDREFs) assumed for these estimates are indicated in the heading for each table. A DDREF value of 2 is used for all cancer sites except breast, for which a DDREF of 1 is used.

Table B-1. Risk Models, DDREFs, RBEs and Lethality Fractions Assumed by EPA for Specific Cancer Sites for Radiation Risk Assessment

Cancer Site	Risk Model	DDREF	RBE	Lethality Fraction
Esophagus	Absolute	2	20	0.95
Stomach	Absolute	2	20	0.90
Colon	Absolute	2	20	0.55
Liver	Absolute	2	20	0.95
Lung	Absolute	2	20	0.95
Bone	Relative	2	20	0.70
Skin	Relative	2	20	0.002*
Breast	Absolute	1	10	0.50
Ovary	Absolute	2	20	0.70
Bladder	Absolute	2	20	0.50
Kidney	Absolute	2	20	0.65
Thyroid	Relative	2	20	0.10
Leukemia	Absolute	2	1	0.99
Residual	Absolute	2	20	0.71

* Skin cancer incidence is calculated only for those cases that are fatal, i.e., the mortality rate is divided by 1.

Table B-2. Attributable Mortality Risk Coefficients: Esophagus (DDREF=2)(Sv⁻¹)

Age	General	Males	Females	Age	General	Males	Females
0	8.0710E-04	5.8165E-04	1.0440E-03	56	1.0235E-03	5.5840E-04	1.4734E-03
1	8.1739E-04	5.8987E-04	1.0559E-03	57	9.8687E-04	5.3317E-04	1.4229E-03
2	8.1815E-04	5.9046E-04	1.0568E-03	58	9.4804E-04	5.0697E-04	1.3690E-03
3	8.1868E-04	5.9088E-04	1.0574E-03	59	9.0958E-04	4.7892E-04	1.3175E-03
4	8.1908E-04	5.9121E-04	1.0578E-03	60	8.7322E-04	4.5041E-04	1.2703E-03
5	8.1941E-04	5.9148E-04	1.0582E-03	61	8.3756E-04	4.2368E-04	1.2228E-03
6	8.1970E-04	5.9172E-04	1.0585E-03	62	8.0035E-04	3.9679E-04	1.1722E-03
7	8.1997E-04	5.9194E-04	1.0588E-03	63	7.6115E-04	3.7004E-04	1.1177E-03
8	8.2022E-04	5.9215E-04	1.0590E-03	64	7.2281E-04	3.4547E-04	1.0627E-03
9	8.2044E-04	5.9234E-04	1.0593E-03	65	6.8640E-04	3.2135E-04	1.0109E-03
10	8.3745E-04	6.0216E-04	1.0838E-03	66	6.4945E-04	2.9676E-04	9.5857E-04
11	8.5442E-04	6.1194E-04	1.1083E-03	67	6.1217E-04	2.7351E-04	9.0445E-04
12	8.5458E-04	6.1205E-04	1.1085E-03	68	5.7595E-04	2.5215E-04	8.5078E-04
13	8.5477E-04	6.1220E-04	1.1087E-03	69	5.4257E-04	2.3181E-04	8.0164E-04
14	8.5503E-04	6.1247E-04	1.1089E-03	70	5.0956E-04	2.1240E-04	7.5250E-04
15	8.5544E-04	6.1289E-04	1.1092E-03	71	4.7319E-04	1.9315E-04	6.9739E-04
16	8.5601E-04	6.1345E-04	1.1096E-03	72	4.3750E-04	1.7497E-04	6.4294E-04
17	8.5671E-04	6.1417E-04	1.1101E-03	73	4.0519E-04	1.5848E-04	5.9358E-04
18	8.5752E-04	6.1500E-04	1.1107E-03	74	3.7128E-04	1.4065E-04	5.4287E-04
19	8.5837E-04	6.1591E-04	1.1112E-03	75	3.3352E-04	1.2272E-04	4.8611E-04
20	9.1313E-04	6.4422E-04	1.1933E-03	76	2.9716E-04	1.0757E-04	4.3045E-04
21	9.6808E-04	6.7269E-04	1.2754E-03	77	2.6959E-04	9.3865E-05	3.8935E-04
22	9.6927E-04	6.7390E-04	1.2762E-03	78	2.4116E-04	8.0987E-05	3.4680E-04
23	9.7045E-04	6.7514E-04	1.2769E-03	79	2.0644E-04	6.9602E-05	2.9364E-04
24	9.7149E-04	6.7636E-04	1.2773E-03	80	1.7894E-04	5.9020E-05	2.5268E-04
25	9.7248E-04	6.7750E-04	1.2777E-03	81	1.5265E-04	4.9093E-05	2.1400E-04
26	9.7341E-04	6.7855E-04	1.2781E-03	82	1.2527E-04	4.0621E-05	1.7350E-04
27	9.7408E-04	6.7940E-04	1.2782E-03	83	1.0676E-04	3.2877E-05	1.4717E-04
28	9.7455E-04	6.8008E-04	1.2780E-03	84	8.5772E-05	2.6191E-05	1.1699E-04
29	9.7484E-04	6.8057E-04	1.2778E-03	85	6.0957E-05	2.1455E-05	8.0763E-05
30	1.0848E-03	7.3159E-04	1.4480E-03	86	4.5885E-05	1.7740E-05	5.9373E-05
31	1.1949E-03	7.8253E-04	1.6185E-03	87	3.7977E-05	1.4502E-05	4.8716E-05
32	1.1948E-03	7.8243E-04	1.6178E-03	88	3.1379E-05	1.1847E-05	3.9897E-05
33	1.1937E-03	7.8163E-04	1.6160E-03	89	2.5908E-05	9.6831E-06	3.2644E-05
34	1.1918E-03	7.8011E-04	1.6132E-03	90	2.1411E-05	7.9292E-06	2.6735E-05
35	1.1890E-03	7.7806E-04	1.6091E-03	91	1.7769E-05	6.5218E-06	2.1993E-05
36	1.1856E-03	7.7519E-04	1.6047E-03	92	1.4874E-05	5.4089E-06	1.8255E-05
37	1.1824E-03	7.7185E-04	1.6013E-03	93	1.2615E-05	4.5452E-06	1.5354E-05
38	1.1773E-03	7.6800E-04	1.5944E-03	94	1.0893E-05	3.8927E-06	1.3147E-05
39	1.1703E-03	7.6302E-04	1.5848E-03	95	9.6370E-06	3.4191E-06	1.1531E-05
40	1.2954E-03	8.0475E-04	1.7940E-03	96	8.8043E-06	3.1029E-06	1.0445E-05
41	1.4161E-03	8.4464E-04	1.9960E-03	97	8.3736E-06	2.9314E-06	9.8540E-06
42	1.4021E-03	8.3503E-04	1.9768E-03	98	8.3687E-06	2.9153E-06	9.7716E-06
43	1.3876E-03	8.2278E-04	1.9590E-03	99	8.8616E-06	3.0854E-06	1.0268E-05
44	1.3712E-03	8.0879E-04	1.9391E-03	100	9.9894E-06	3.5016E-06	1.1486E-05
45	1.3519E-03	7.9483E-04	1.9133E-03	101	1.1654E-05	4.1326E-06	1.3301E-05
46	1.3306E-03	7.8025E-04	1.8841E-03	102	1.3561E-05	4.8602E-06	1.5370E-05
47	1.3077E-03	7.6327E-04	1.8540E-03	103	1.5672E-05	5.6714E-06	1.7649E-05
48	1.2817E-03	7.4442E-04	1.8193E-03	104	1.7885E-05	6.5307E-06	2.0023E-05
49	1.2540E-03	7.2457E-04	1.7823E-03	105	1.9987E-05	7.3592E-06	2.2254E-05
50	1.2268E-03	7.0370E-04	1.7470E-03	106	2.1609E-05	8.0207E-06	2.3940E-05
51	1.1980E-03	6.8209E-04	1.7092E-03	107	2.1878E-05	8.1823E-06	2.4124E-05
52	1.1654E-03	6.5923E-04	1.6649E-03	108	2.0454E-05	7.7131E-06	2.2454E-05
53	1.1306E-03	6.3499E-04	1.6176E-03	109	1.3824E-05	5.2909E-06	1.5109E-05
54	1.0942E-03	6.0966E-04	1.5682E-03	110	3.2615E-06	1.2482E-06	3.5523E-06
55	1.0581E-03	5.8373E-04	1.5196E-03				

Table B-3. Attributable Mortality Risk Coefficients: Stomach (DDREF=2)(Sv⁻¹)

Age	General	Males	Females	Age	General	Males	Females
0	7.7487E-03	5.0763E-03	1.0557E-02	56	1.0982E-03	8.6985E-04	1.3190E-03
1	7.8476E-03	5.1480E-03	1.0677E-02	57	1.0786E-03	8.4758E-04	1.3006E-03
2	7.8548E-03	5.1531E-03	1.0686E-02	58	1.0571E-03	8.2440E-04	1.2793E-03
3	7.8599E-03	5.1568E-03	1.0692E-02	59	1.0340E-03	8.0076E-04	1.2549E-03
4	7.8638E-03	5.1598E-03	1.0697E-02	60	1.0091E-03	7.7489E-04	1.2292E-03
5	7.8669E-03	5.1621E-03	1.0700E-02	61	9.8265E-04	7.4724E-04	1.2017E-03
6	7.8697E-03	5.1642E-03	1.0703E-02	62	9.5452E-04	7.1886E-04	1.1717E-03
7	7.8722E-03	5.1661E-03	1.0706E-02	63	9.2406E-04	6.9035E-04	1.1371E-03
8	7.8745E-03	5.1678E-03	1.0708E-02	64	8.9098E-04	6.6061E-04	1.0985E-03
9	7.8764E-03	5.1694E-03	1.0711E-02	65	8.5707E-04	6.2946E-04	1.0594E-03
10	9.2363E-03	6.6015E-03	1.1995E-02	66	8.2314E-04	5.9679E-04	1.0215E-03
11	1.0598E-02	8.0341E-03	1.3279E-02	67	7.8797E-04	5.6194E-04	9.8305E-04
12	1.0598E-02	8.0356E-03	1.3281E-02	68	7.5242E-04	5.2713E-04	9.4365E-04
13	1.0600E-02	8.0375E-03	1.3283E-02	69	7.1577E-04	4.9457E-04	9.0017E-04
14	1.0603E-02	8.0402E-03	1.3285E-02	70	6.7534E-04	4.6167E-04	8.5004E-04
15	1.0607E-02	8.0446E-03	1.3288E-02	71	6.3206E-04	4.2536E-04	7.9755E-04
16	1.0613E-02	8.0510E-03	1.3291E-02	72	5.892E-04	3.8913E-04	7.4527E-04
17	1.0619E-02	8.0590E-03	1.3294E-02	73	5.4759E-04	3.5560E-04	6.9421E-04
18	1.0626E-02	8.0684E-03	1.3297E-02	74	5.0498E-04	3.2316E-04	6.4026E-04
19	1.0635E-02	8.0787E-03	1.3301E-02	75	4.5985E-04	2.9231E-04	5.8112E-04
20	1.0464E-02	8.0651E-03	1.2964E-02	76	4.1439E-04	2.6094E-04	5.2228E-04
21	1.0293E-02	8.0519E-03	1.2624E-02	77	3.6818E-04	2.2844E-04	4.6341E-04
22	1.0300E-02	8.0637E-03	1.2623E-02	78	3.2359E-04	1.9967E-04	4.0531E-04
23	1.0307E-02	8.0752E-03	1.2623E-02	79	2.8427E-04	1.7415E-04	3.5445E-04
24	1.0314E-02	8.0860E-03	1.2622E-02	80	2.4708E-04	1.4659E-04	3.0887E-04
25	1.0320E-02	8.0963E-03	1.2620E-02	81	2.1205E-04	1.1881E-04	2.6729E-04
26	1.0324E-02	8.1058E-03	1.2617E-02	82	1.8156E-04	9.8039E-05	2.2914E-04
27	1.0327E-02	8.1138E-03	1.2611E-02	83	1.5259E-04	8.2497E-05	1.9092E-04
28	1.0328E-02	8.1196E-03	1.2605E-02	84	1.2810E-04	6.7939E-05	1.5963E-04
29	1.0329E-02	8.1249E-03	1.2598E-02	85	1.0836E-04	5.5091E-05	1.3507E-04
30	5.9191E-03	4.6797E-03	7.1934E-03	86	8.9934E-05	4.4641E-05	1.1164E-04
31	1.5104E-03	1.2298E-03	1.7986E-03	87	7.4304E-05	3.6493E-05	9.1601E-05
32	1.5095E-03	1.2294E-03	1.7968E-03	88	6.1291E-05	2.9813E-05	7.5018E-05
33	1.5079E-03	1.2284E-03	1.7943E-03	89	5.0522E-05	2.4367E-05	6.1381E-05
34	1.5060E-03	1.2269E-03	1.7918E-03	90	4.1688E-05	1.9953E-05	5.0271E-05
35	1.5039E-03	1.2251E-03	1.7891E-03	91	3.4545E-05	1.6412E-05	4.1354E-05
36	1.5014E-03	1.2225E-03	1.7862E-03	92	2.8874E-05	1.3611E-05	3.4325E-05
37	1.4981E-03	1.2190E-03	1.7829E-03	93	2.4452E-05	1.1438E-05	2.8871E-05
38	1.4942E-03	1.2156E-03	1.7781E-03	94	2.1085E-05	9.7957E-06	2.4721E-05
39	1.4901E-03	1.2116E-03	1.7735E-03	95	1.8628E-05	8.6039E-06	2.1683E-05
40	1.3792E-03	1.1323E-03	1.6301E-03	96	1.6996E-05	7.8083E-06	1.9641E-05
41	1.2683E-03	1.0533E-03	1.4865E-03	97	1.6144E-05	7.3769E-06	1.8529E-05
42	1.2633E-03	1.0480E-03	1.4814E-03	98	1.6115E-05	7.3363E-06	1.8374E-05
43	1.2571E-03	1.0416E-03	1.4752E-03	99	1.7047E-05	7.7644E-06	1.9307E-05
44	1.2501E-03	1.0341E-03	1.4682E-03	100	1.9201E-05	8.8117E-06	2.1598E-05
45	1.2430E-03	1.0262E-03	1.4615E-03	101	2.2386E-05	1.0399E-05	2.5010E-05
46	1.2354E-03	1.0177E-03	1.4544E-03	102	2.6031E-05	1.2230E-05	2.8901E-05
47	1.2262E-03	1.0076E-03	1.4455E-03	103	3.0063E-05	1.4272E-05	3.3186E-05
48	1.2160E-03	9.9666E-04	1.4354E-03	104	3.4288E-05	1.6434E-05	3.7650E-05
49	1.2052E-03	9.8546E-04	1.4245E-03	105	3.8294E-05	1.8519E-05	4.1845E-05
50	1.1929E-03	9.7289E-04	1.4118E-03	106	4.1379E-05	2.0184E-05	4.5014E-05
51	1.1794E-03	9.5872E-04	1.3982E-03	107	4.1871E-05	2.0591E-05	4.5360E-05
52	1.1654E-03	9.4337E-04	1.3846E-03	108	3.9125E-05	1.9410E-05	4.2220E-05
53	1.1507E-03	9.2699E-04	1.3705E-03	109	2.6434E-05	1.3314E-05	2.8409E-05
54	1.1350E-03	9.0960E-04	1.3555E-03	110	6.2328E-06	3.1409E-06	6.6794E-06
55	1.1172E-03	8.9034E-04	1.3380E-03				

Table B-4. Attributable Mortality Risk Coefficients: Colon (DDREF=2)(Sv⁻¹)

Age	General	Males	Females	Age	General	Males	Females
0	2.8462E-02	2.1918E-02	3.5340E-02	56	1.3830E-03	8.0230E-04	1.9447E-03
1	2.8825E-02	2.2227E-02	3.5740E-02	57	1.3586E-03	7.8457E-04	1.9102E-03
2	2.8851E-02	2.2249E-02	3.5770E-02	58	1.3326E-03	7.6502E-04	1.8743E-03
3	2.8870E-02	2.2265E-02	3.5790E-02	59	1.3046E-03	7.4349E-04	1.8361E-03
4	2.8884E-02	2.2278E-02	3.5805E-02	60	1.2744E-03	7.2104E-04	1.7942E-03
5	2.8896E-02	2.2288E-02	3.5817E-02	61	1.2417E-03	6.9735E-04	1.7484E-03
6	2.8906E-02	2.2297E-02	3.5828E-02	62	1.2063E-03	6.7124E-04	1.6993E-03
7	2.8915E-02	2.2305E-02	3.5837E-02	63	1.1686E-03	6.4383E-04	1.6470E-03
8	2.8923E-02	2.2312E-02	3.5845E-02	64	1.1292E-03	6.1588E-04	1.5916E-03
9	2.8930E-02	2.2318E-02	3.5853E-02	65	1.0883E-03	5.8684E-04	1.5341E-03
10	2.8936E-02	2.2323E-02	3.5858E-02	66	1.0454E-03	5.5664E-04	1.4737E-03
11	2.8939E-02	2.2326E-02	3.5862E-02	67	9.9954E-04	5.2560E-04	1.4086E-03
12	2.8943E-02	2.2329E-02	3.5867E-02	68	9.5133E-04	4.9475E-04	1.3389E-03
13	2.8948E-02	2.2332E-02	3.5872E-02	69	9.0155E-04	4.6443E-04	1.2660E-03
14	2.8956E-02	2.2340E-02	3.5879E-02	70	8.5070E-04	4.3367E-04	1.1917E-03
15	2.8969E-02	2.2354E-02	3.5888E-02	71	7.9747E-04	4.0227E-04	1.1139E-03
16	2.8985E-02	2.2372E-02	3.5899E-02	72	7.4123E-04	3.7040E-04	1.0314E-03
17	2.9005E-02	2.2394E-02	3.5912E-02	73	6.8429E-04	3.3779E-04	9.4890E-04
18	2.9027E-02	2.2418E-02	3.5925E-02	74	6.2720E-04	3.0589E-04	8.6626E-04
19	2.9049E-02	2.2445E-02	3.5937E-02	75	5.7019E-04	2.7433E-04	7.8435E-04
20	1.6991E-02	1.2701E-02	2.1460E-02	76	5.1372E-04	2.4301E-04	7.0404E-04
21	4.9123E-03	2.9314E-03	6.9732E-03	77	4.5743E-04	2.1394E-04	6.2338E-04
22	4.9170E-03	2.9360E-03	6.9754E-03	78	4.0258E-04	1.8577E-04	5.4558E-04
23	4.9217E-03	2.9407E-03	6.9771E-03	79	3.5105E-04	1.5859E-04	4.7369E-04
24	4.9262E-03	2.9452E-03	6.9786E-03	80	3.0444E-04	1.3410E-04	4.0917E-04
25	4.9304E-03	2.9496E-03	6.9799E-03	81	2.6269E-04	1.1245E-04	3.5170E-04
26	4.9342E-03	2.9534E-03	6.9810E-03	82	2.2443E-04	9.4085E-05	2.9870E-04
27	4.9371E-03	2.9566E-03	6.9808E-03	83	1.8913E-04	7.8031E-05	2.4990E-04
28	4.9392E-03	2.9592E-03	6.9798E-03	84	1.5618E-04	6.2353E-05	2.0534E-04
29	4.9410E-03	2.9614E-03	6.9788E-03	85	1.2759E-04	4.8516E-05	1.6724E-04
30	6.0606E-03	3.7367E-03	8.4499E-03	86	1.0526E-04	3.8798E-05	1.3711E-04
31	7.1793E-03	4.5121E-03	9.9183E-03	87	8.7143E-05	3.1716E-05	1.1250E-04
32	7.1780E-03	4.5126E-03	9.9123E-03	88	7.2022E-05	2.5911E-05	9.2131E-05
33	7.1754E-03	4.5120E-03	9.9045E-03	89	5.9480E-05	2.1178E-05	7.5383E-05
34	7.1710E-03	4.5102E-03	9.8946E-03	90	4.9169E-05	1.7342E-05	6.1739E-05
35	7.1654E-03	4.5075E-03	9.8829E-03	91	4.0816E-05	1.4264E-05	5.0788E-05
36	7.1581E-03	4.5044E-03	9.8685E-03	92	3.4174E-05	1.1830E-05	4.2156E-05
37	7.1485E-03	4.5000E-03	9.8502E-03	93	2.8990E-05	9.9409E-06	3.5457E-05
38	7.1365E-03	4.4937E-03	9.8293E-03	94	2.5039E-05	8.5136E-06	3.0361E-05
39	7.1223E-03	4.4851E-03	9.8060E-03	95	2.2157E-05	7.4778E-06	2.6629E-05
40	4.3437E-03	2.7074E-03	6.0067E-03	96	2.0247E-05	6.7863E-06	2.4121E-05
41	1.5777E-03	9.3810E-04	2.2269E-03	97	1.9260E-05	6.4113E-06	2.2755E-05
42	1.5725E-03	9.3480E-04	2.2186E-03	98	1.9252E-05	6.3761E-06	2.2565E-05
43	1.5663E-03	9.3079E-04	2.2092E-03	99	2.0390E-05	6.7481E-06	2.3712E-05
44	1.5596E-03	9.2643E-04	2.1990E-03	100	2.2988E-05	7.6583E-06	2.6525E-05
45	1.5519E-03	9.2145E-04	2.1874E-03	101	2.6822E-05	9.0383E-06	3.0715E-05
46	1.5429E-03	9.1546E-04	2.1739E-03	102	3.1214E-05	1.0630E-05	3.5494E-05
47	1.5327E-03	9.0841E-04	2.1590E-03	103	3.6076E-05	1.2404E-05	4.0756E-05
48	1.5214E-03	9.0071E-04	2.1425E-03	104	4.1174E-05	1.4283E-05	4.6238E-05
49	1.5089E-03	8.9231E-04	2.1241E-03	105	4.6017E-05	1.6095E-05	5.1391E-05
50	1.4951E-03	8.8250E-04	2.1044E-03	106	4.9758E-05	1.7542E-05	5.5283E-05
51	1.4804E-03	8.7208E-04	2.0833E-03	107	5.0381E-05	1.7896E-05	5.5708E-05
52	1.4647E-03	8.6136E-04	2.0601E-03	108	4.7105E-05	1.6869E-05	5.1852E-05
53	1.4474E-03	8.4916E-04	2.0354E-03	109	3.1839E-05	1.1572E-05	3.4890E-05
54	1.4283E-03	8.3510E-04	2.0084E-03	110	7.5123E-06	2.7298E-06	8.2031E-06
55	1.4066E-03	8.1923E-04	1.9780E-03				

Table B-5. Attributable Mortality Risk Coefficients: Liver (DDREF=2)(Sv⁻¹)

Age	General	Males	Females	Age	General	Males	Females
0	1.8102E-03	2.0737E-03	1.5333E-03	56	1.4242E-03	1.6039E-03	1.2505E-03
1	1.8330E-03	2.1026E-03	1.5505E-03	57	1.3809E-03	1.5468E-03	1.2215E-03
2	1.8345E-03	2.1044E-03	1.5515E-03	58	1.3386E-03	1.4910E-03	1.1932E-03
3	1.8355E-03	2.1057E-03	1.5523E-03	59	1.2935E-03	1.4321E-03	1.1623E-03
4	1.8361E-03	2.1066E-03	1.5528E-03	60	1.2444E-03	1.3687E-03	1.1276E-03
5	1.8364E-03	2.1071E-03	1.5528E-03	61	1.1915E-03	1.3011E-03	1.0896E-03
6	1.8365E-03	2.1074E-03	1.5527E-03	62	1.1367E-03	1.2291E-03	1.0515E-03
7	1.8366E-03	2.1077E-03	1.5527E-03	63	1.0808E-03	1.1576E-03	1.0108E-03
8	1.8366E-03	2.1079E-03	1.5527E-03	64	1.0245E-03	1.0882E-03	9.6708E-04
9	1.8365E-03	2.1079E-03	1.5524E-03	65	9.6867E-04	1.0172E-03	9.2552E-04
10	1.8363E-03	2.1078E-03	1.5521E-03	66	9.1256E-04	9.4599E-04	8.8325E-04
11	1.8361E-03	2.1076E-03	1.5519E-03	67	8.5536E-04	8.7353E-04	8.3967E-04
12	1.8356E-03	2.1072E-03	1.5511E-03	68	7.9867E-04	7.9946E-04	7.9799E-04
13	1.8349E-03	2.1066E-03	1.5504E-03	69	7.4318E-04	7.2727E-04	7.5645E-04
14	1.8347E-03	2.1065E-03	1.5503E-03	70	6.8802E-04	6.6314E-04	7.0836E-04
15	1.8349E-03	2.1071E-03	1.5502E-03	71	6.3410E-04	6.0885E-04	6.5431E-04
16	1.8351E-03	2.1080E-03	1.5498E-03	72	5.8074E-04	5.5296E-04	6.0247E-04
17	1.8356E-03	2.1094E-03	1.5496E-03	73	5.2838E-04	4.9614E-04	5.5300E-04
18	1.8364E-03	2.1111E-03	1.5496E-03	74	4.7739E-04	4.4443E-04	5.0191E-04
19	1.8370E-03	2.1129E-03	1.5493E-03	75	4.2407E-04	3.8773E-04	4.5038E-04
20	1.8376E-03	2.1148E-03	1.5488E-03	76	3.7020E-04	3.3248E-04	3.9672E-04
21	1.8381E-03	2.1165E-03	1.5484E-03	77	3.2311E-04	2.9001E-04	3.4567E-04
22	1.8388E-03	2.1185E-03	1.5483E-03	78	2.8047E-04	2.4943E-04	3.0094E-04
23	1.8398E-03	2.1208E-03	1.5482E-03	79	2.3598E-04	2.0574E-04	2.5525E-04
24	1.8406E-03	2.1232E-03	1.5478E-03	80	1.9680E-04	1.7063E-04	2.1289E-04
25	1.8413E-03	2.1254E-03	1.5473E-03	81	1.6542E-04	1.4546E-04	1.7725E-04
26	1.8418E-03	2.1273E-03	1.5468E-03	82	1.3570E-04	1.2017E-04	1.4455E-04
27	1.8417E-03	2.1287E-03	1.5455E-03	83	1.0915E-04	9.4649E-05	1.1709E-04
28	1.8416E-03	2.1301E-03	1.5441E-03	84	8.6504E-05	7.2443E-05	9.3872E-05
29	1.8414E-03	2.1315E-03	1.5429E-03	85	6.7033E-05	5.5537E-05	7.2797E-05
30	1.8405E-03	2.1318E-03	1.5411E-03	86	5.3135E-05	4.4304E-05	5.7367E-05
31	1.8387E-03	2.1309E-03	1.5387E-03	87	4.3664E-05	3.6218E-05	4.7070E-05
32	1.8371E-03	2.1300E-03	1.5366E-03	88	3.5828E-05	2.9588E-05	3.8549E-05
33	1.8351E-03	2.1286E-03	1.5343E-03	89	2.9383E-05	2.4183E-05	3.1541E-05
34	1.8318E-03	2.1255E-03	1.5312E-03	90	2.4125E-05	1.9803E-05	2.5832E-05
35	1.8280E-03	2.1217E-03	1.5276E-03	91	1.9896E-05	1.6288E-05	2.1250E-05
36	1.8233E-03	2.1172E-03	1.5231E-03	92	1.6552E-05	1.3509E-05	1.7639E-05
37	1.8173E-03	2.1108E-03	1.5178E-03	93	1.3953E-05	1.1352E-05	1.4836E-05
38	1.8106E-03	2.1030E-03	1.5128E-03	94	1.1977E-05	9.7218E-06	1.2703E-05
39	1.8031E-03	2.0945E-03	1.5067E-03	95	1.0534E-05	8.5390E-06	1.1142E-05
40	1.7934E-03	2.0835E-03	1.4985E-03	96	9.5688E-06	7.7493E-06	1.0093E-05
41	1.7823E-03	2.0696E-03	1.4907E-03	97	9.0507E-06	7.3212E-06	9.5211E-06
42	1.7713E-03	2.0546E-03	1.4842E-03	98	8.9994E-06	7.2810E-06	9.4415E-06
43	1.7592E-03	2.0388E-03	1.4763E-03	99	9.4874E-06	7.7058E-06	9.9213E-06
44	1.7465E-03	2.0226E-03	1.4676E-03	100	1.0657E-05	8.7452E-06	1.1098E-05
45	1.7328E-03	2.0051E-03	1.4583E-03	101	1.2397E-05	1.0321E-05	1.2851E-05
46	1.7149E-03	1.9817E-03	1.4467E-03	102	1.4384E-05	1.2138E-05	1.4851E-05
47	1.6934E-03	1.9529E-03	1.4330E-03	103	1.6576E-05	1.4164E-05	1.7053E-05
48	1.6726E-03	1.9272E-03	1.4178E-03	104	1.8866E-05	1.6310E-05	1.9347E-05
49	1.6514E-03	1.9011E-03	1.4024E-03	105	2.1027E-05	1.8379E-05	2.1502E-05
50	1.6273E-03	1.8685E-03	1.3873E-03	106	2.2677E-05	2.0031E-05	2.3131E-05
51	1.6006E-03	1.8320E-03	1.3713E-03	107	2.2904E-05	2.0435E-05	2.3309E-05
52	1.5715E-03	1.7935E-03	1.3525E-03	108	2.1365E-05	1.9263E-05	2.1695E-05
53	1.5394E-03	1.7528E-03	1.3298E-03	109	1.4417E-05	1.3214E-05	1.4598E-05
54	1.5043E-03	1.7089E-03	1.3042E-03	110	3.3925E-06	3.1172E-06	3.4323E-06
55	1.4664E-03	1.6598E-03	1.2783E-03				

Table B-6. Attributable Mortality Risk Coefficients: Lung (DDREF=2)(Sv⁻¹)

Age	General	Males	Females	Age	General	Males	Females
0	1.5378E-02	1.3711E-02	1.7130E-02	56	5.2592E-03	4.3294E-03	6.1584E-03
1	1.5574E-02	1.3904E-02	1.7324E-02	57	5.0060E-03	4.1345E-03	5.8435E-03
2	1.5588E-02	1.3918E-02	1.7338E-02	58	4.7467E-03	3.9309E-03	5.5253E-03
3	1.5598E-02	1.3928E-02	1.7348E-02	59	4.4848E-03	3.7199E-03	5.2094E-03
4	1.5606E-02	1.3936E-02	1.7355E-02	60	4.2256E-03	3.5058E-03	4.9016E-03
5	1.5612E-02	1.3943E-02	1.7361E-02	61	3.9627E-03	3.2876E-03	4.5910E-03
6	1.5618E-02	1.3949E-02	1.7366E-02	62	3.6972E-03	3.0626E-03	4.2820E-03
7	1.5623E-02	1.3954E-02	1.7371E-02	63	3.4376E-03	2.8380E-03	3.9841E-03
8	1.5627E-02	1.3959E-02	1.7374E-02	64	3.1837E-03	2.6188E-03	3.6925E-03
9	1.5632E-02	1.3963E-02	1.7378E-02	65	2.9352E-03	2.4018E-03	3.4093E-03
10	1.5635E-02	1.3967E-02	1.7381E-02	66	2.6991E-03	2.1888E-03	3.1463E-03
11	1.5638E-02	1.3970E-02	1.7384E-02	67	2.4693E-03	1.9818E-03	2.8901E-03
12	1.5641E-02	1.3972E-02	1.7387E-02	68	2.2409E-03	1.7790E-03	2.6330E-03
13	1.5644E-02	1.3976E-02	1.7390E-02	69	2.0272E-03	1.5855E-03	2.3955E-03
14	1.5649E-02	1.3983E-02	1.7394E-02	70	1.8290E-03	1.4058E-03	2.1751E-03
15	1.5657E-02	1.3993E-02	1.7399E-02	71	1.6419E-03	1.2384E-03	1.9648E-03
16	1.5668E-02	1.4006E-02	1.7405E-02	72	1.4664E-03	1.0817E-03	1.7675E-03
17	1.5680E-02	1.4022E-02	1.7412E-02	73	1.2999E-03	9.3493E-04	1.5786E-03
18	1.5694E-02	1.4040E-02	1.7420E-02	74	1.1452E-03	7.9949E-04	1.4025E-03
19	1.5709E-02	1.4061E-02	1.7428E-02	75	1.0036E-03	6.7712E-04	1.2398E-03
20	8.8600E-03	7.8274E-03	9.9358E-03	76	8.6877E-04	5.6701E-04	1.0809E-03
21	1.9967E-03	1.5741E-03	2.4365E-03	77	7.4572E-04	4.6809E-04	9.3493E-04
22	1.9989E-03	1.5770E-03	2.4373E-03	78	6.3645E-04	3.8249E-04	8.0395E-04
23	2.0010E-03	1.5799E-03	2.4380E-03	79	5.3912E-04	3.1120E-04	6.8436E-04
24	2.0031E-03	1.5828E-03	2.4386E-03	80	4.5756E-04	2.5264E-04	5.8357E-04
25	2.0049E-03	1.5855E-03	2.4390E-03	81	3.8590E-04	2.0502E-04	4.9306E-04
26	2.0064E-03	1.5880E-03	2.4387E-03	82	3.2069E-04	1.6548E-04	4.0912E-04
27	2.0073E-03	1.5902E-03	2.4378E-03	83	2.6547E-04	1.3369E-04	3.3753E-04
28	2.0078E-03	1.5920E-03	2.4364E-03	84	2.1968E-04	1.0790E-04	2.7826E-04
29	2.0076E-03	1.5934E-03	2.4340E-03	85	1.7825E-04	8.4830E-05	2.2509E-04
30	3.8972E-03	3.1586E-03	4.6566E-03	86	1.4369E-04	6.6958E-05	1.8047E-04
31	5.7828E-03	4.7236E-03	6.8706E-03	87	1.1878E-04	5.4737E-05	1.4807E-04
32	5.7742E-03	4.7224E-03	6.8532E-03	88	9.8023E-05	4.4718E-05	1.2127E-04
33	5.7626E-03	4.7196E-03	6.8314E-03	89	8.0836E-05	3.6549E-05	9.9224E-05
34	5.7478E-03	4.7139E-03	6.8061E-03	90	6.6730E-05	2.9929E-05	8.1264E-05
35	5.7278E-03	4.7051E-03	6.7735E-03	91	5.5320E-05	2.4617E-05	6.6850E-05
36	5.7024E-03	4.6936E-03	6.7327E-03	92	4.6257E-05	2.0416E-05	5.5488E-05
37	5.6710E-03	4.6784E-03	6.6836E-03	93	3.9190E-05	1.7156E-05	4.6671E-05
38	5.6341E-03	4.6587E-03	6.6281E-03	94	3.3807E-05	1.4693E-05	3.9962E-05
39	5.5919E-03	4.6333E-03	6.5674E-03	95	2.9879E-05	1.2905E-05	3.5051E-05
40	6.7063E-03	5.3778E-03	8.0564E-03	96	2.7271E-05	1.1712E-05	3.1749E-05
41	7.7876E-03	6.1046E-03	9.4956E-03	97	2.5913E-05	1.1065E-05	2.9952E-05
42	7.6951E-03	6.0496E-03	9.3626E-03	98	2.5875E-05	1.1004E-05	2.9701E-05
43	7.5940E-03	5.9882E-03	9.2185E-03	99	2.7380E-05	1.1646E-05	3.1211E-05
44	7.4818E-03	5.9164E-03	9.0626E-03	100	3.0846E-05	1.3217E-05	3.4913E-05
45	7.3591E-03	5.8354E-03	8.8949E-03	101	3.5970E-05	1.5598E-05	4.0429E-05
46	7.2255E-03	5.7473E-03	8.7122E-03	102	4.1835E-05	1.8345E-05	4.6719E-05
47	7.0799E-03	5.6495E-03	8.5152E-03	103	4.8323E-05	2.1407E-05	5.3646E-05
48	6.9255E-03	5.5440E-03	8.3081E-03	104	5.5123E-05	2.4650E-05	6.0862E-05
49	6.7609E-03	5.4314E-03	8.0875E-03	105	6.1574E-05	2.7777E-05	6.7643E-05
50	6.5821E-03	5.3062E-03	7.8510E-03	106	6.6546E-05	3.0274E-05	7.2766E-05
51	6.3914E-03	5.1684E-03	7.6033E-03	107	6.7347E-05	3.0884E-05	7.3326E-05
52	6.1888E-03	5.0205E-03	7.3419E-03	108	6.2940E-05	2.9113E-05	6.8250E-05
53	5.9732E-03	4.8633E-03	7.0639E-03	109	4.2529E-05	1.9971E-05	4.5924E-05
54	5.7478E-03	4.6967E-03	6.7757E-03	110	1.0029E-05	4.7112E-06	1.0797E-05
55	5.5089E-03	4.5177E-03	6.4731E-03				

Table B-7. Attributable Mortality Risk Coefficients: Bone (DDREF=2)(Sv⁻¹)

Age	General	Males	Females	Age	General	Males	Females
0	1.1344E-04	1.1305E-04	1.1385E-04	56	8.5230E-05	7.7540E-05	9.2668E-05
1	1.1480E-04	1.1452E-04	1.1509E-04	57	8.3247E-05	7.5264E-05	9.0919E-05
2	1.1482E-04	1.1451E-04	1.1513E-04	58	8.1176E-05	7.2924E-05	8.9051E-05
3	1.1480E-04	1.1446E-04	1.1515E-04	59	7.9021E-05	7.0528E-05	8.7065E-05
4	1.1476E-04	1.1439E-04	1.1514E-04	60	7.6788E-05	6.8087E-05	8.4960E-05
5	1.1470E-04	1.1430E-04	1.1513E-04	61	7.4485E-05	6.5615E-05	8.2742E-05
6	1.1464E-04	1.1419E-04	1.1510E-04	62	7.2121E-05	6.3118E-05	8.0416E-05
7	1.1456E-04	1.1408E-04	1.1507E-04	63	6.9702E-05	6.0611E-05	7.7988E-05
8	1.1448E-04	1.1395E-04	1.1504E-04	64	6.7234E-05	5.8100E-05	7.5460E-05
9	1.1439E-04	1.1381E-04	1.1499E-04	65	6.4721E-05	5.5592E-05	7.2837E-05
10	1.1428E-04	1.1365E-04	1.1494E-04	66	6.2168E-05	5.3089E-05	7.0125E-05
11	1.1417E-04	1.1348E-04	1.1489E-04	67	5.9583E-05	5.0600E-05	6.7337E-05
12	1.1404E-04	1.1330E-04	1.1483E-04	68	5.6979E-05	4.8133E-05	6.4488E-05
13	1.1392E-04	1.1312E-04	1.1476E-04	69	5.4372E-05	4.5702E-05	6.1600E-05
14	1.1380E-04	1.1295E-04	1.1470E-04	70	5.1779E-05	4.3322E-05	5.8694E-05
15	1.1370E-04	1.1280E-04	1.1464E-04	71	4.9214E-05	4.1001E-05	5.5788E-05
16	1.1360E-04	1.1266E-04	1.1458E-04	72	4.6684E-05	3.8748E-05	5.2894E-05
17	1.1351E-04	1.1255E-04	1.1452E-04	73	4.4193E-05	3.6558E-05	5.0024E-05
18	1.1343E-04	1.1244E-04	1.1447E-04	74	4.1743E-05	3.4427E-05	4.7187E-05
19	1.1335E-04	1.1233E-04	1.1440E-04	75	3.9335E-05	3.2350E-05	4.4391E-05
20	1.1326E-04	1.1223E-04	1.1433E-04	76	3.6971E-05	3.0331E-05	4.1639E-05
21	1.1317E-04	1.1213E-04	1.1425E-04	77	3.4660E-05	2.8377E-05	3.8943E-05
22	1.1307E-04	1.1203E-04	1.1415E-04	78	3.2413E-05	2.6492E-05	3.6319E-05
23	1.1296E-04	1.1191E-04	1.1405E-04	79	3.0241E-05	2.4678E-05	3.3786E-05
24	1.1284E-04	1.1178E-04	1.1393E-04	80	2.8156E-05	2.2942E-05	3.1363E-05
25	1.1269E-04	1.1162E-04	1.1380E-04	81	2.6169E-05	2.1293E-05	2.9058E-05
26	1.1252E-04	1.1142E-04	1.1365E-04	82	2.4285E-05	1.9741E-05	2.6874E-05
27	1.1232E-04	1.1118E-04	1.1349E-04	83	2.2503E-05	1.8284E-05	2.4810E-05
28	1.1209E-04	1.1091E-04	1.1330E-04	84	2.0817E-05	1.6914E-05	2.2862E-05
29	1.1182E-04	1.1059E-04	1.1309E-04	85	1.9223E-05	1.5621E-05	2.1029E-05
30	1.1153E-04	1.1023E-04	1.1286E-04	86	1.7727E-05	1.4410E-05	1.9317E-05
31	1.1120E-04	1.0982E-04	1.1261E-04	87	1.6336E-05	1.3285E-05	1.7732E-05
32	1.1083E-04	1.0936E-04	1.1233E-04	88	1.5034E-05	1.2236E-05	1.6255E-05
33	1.1041E-04	1.0884E-04	1.1202E-04	89	1.3807E-05	1.1248E-05	1.4869E-05
34	1.0996E-04	1.0827E-04	1.1169E-04	90	1.2649E-05	1.0314E-05	1.3572E-05
35	1.0946E-04	1.0764E-04	1.1133E-04	91	1.1576E-05	9.4371E-06	1.2379E-05
36	1.0892E-04	1.0695E-04	1.1093E-04	92	1.0604E-05	8.6319E-06	1.1308E-05
37	1.0833E-04	1.0619E-04	1.1050E-04	93	9.7364E-06	7.9119E-06	1.0356E-05
38	1.0769E-04	1.0537E-04	1.1004E-04	94	8.9704E-06	7.2871E-06	9.5124E-06
39	1.0699E-04	1.0448E-04	1.0954E-04	95	8.3018E-06	6.7554E-06	8.7729E-06
40	1.0624E-04	1.0352E-04	1.0901E-04	96	7.7265E-06	6.3063E-06	8.1353E-06
41	1.0543E-04	1.0248E-04	1.0843E-04	97	7.2308E-06	5.9188E-06	7.5877E-06
42	1.0457E-04	1.0137E-04	1.0781E-04	98	6.8091E-06	5.5876E-06	7.1233E-06
43	1.0365E-04	1.0019E-04	1.0715E-04	99	6.4594E-06	5.3098E-06	6.7393E-06
44	1.0266E-04	9.8930E-05	1.0644E-04	100	6.1829E-06	5.0860E-06	6.4360E-06
45	1.0161E-04	9.7587E-05	1.0567E-04	101	5.9866E-06	4.9203E-06	6.2200E-06
46	1.0049E-04	9.6160E-05	1.0485E-04	102	5.8837E-06	4.8227E-06	6.1043E-06
47	9.9303E-05	9.4649E-05	1.0397E-04	103	5.9000E-06	4.8124E-06	6.1150E-06
48	9.8042E-05	9.3059E-05	1.0303E-04	104	6.0779E-06	4.9237E-06	6.2953E-06
49	9.6713E-05	9.1391E-05	1.0202E-04	105	6.4870E-06	5.2133E-06	6.7157E-06
50	9.5312E-05	8.9647E-05	1.0095E-04	106	7.2398E-06	5.7766E-06	7.4908E-06
51	9.3837E-05	8.7824E-05	9.9796E-05	107	8.5149E-06	6.7694E-06	8.8011E-06
52	9.2283E-05	8.5920E-05	9.8563E-05	108	1.0626E-05	8.4725E-06	1.0964E-05
53	9.0646E-05	8.3936E-05	9.7240E-05	109	1.3582E-05	1.0900E-05	1.3985E-05
54	8.8926E-05	8.1876E-05	9.5821E-05	110	1.7211E-05	1.3887E-05	1.7692E-05
55	8.7122E-05	7.9744E-05	9.4299E-05				

Table B-8. Attributable Mortality Risk Coefficients: Skin (DDREF=2)(Sv⁻¹)

Age	General	Males	Females	Age	General	Males	Females
0	2.1462E-04	2.0238E-04	2.2749E-04	56	4.5666E-05	3.7391E-05	5.3668E-05
1	2.1402E-04	2.0190E-04	2.2672E-04	57	4.3234E-05	3.5146E-05	5.1006E-05
2	2.1087E-04	1.9875E-04	2.2356E-04	58	4.0851E-05	3.2961E-05	4.8381E-05
3	2.0766E-04	1.9555E-04	2.2034E-04	59	3.8520E-05	3.0838E-05	4.5795E-05
4	2.0441E-04	1.9232E-04	2.1708E-04	60	3.6244E-05	2.8781E-05	4.3253E-05
5	2.0115E-04	1.8906E-04	2.1381E-04	61	3.4026E-05	2.6793E-05	4.0757E-05
6	1.9787E-04	1.8580E-04	2.1052E-04	62	3.1868E-05	2.4876E-05	3.8310E-05
7	1.9460E-04	1.8253E-04	2.0723E-04	63	2.9772E-05	2.3032E-05	3.5914E-05
8	1.9131E-04	1.7926E-04	2.0393E-04	64	2.7737E-05	2.1262E-05	3.3569E-05
9	1.8802E-04	1.7598E-04	2.0063E-04	65	2.5764E-05	1.9564E-05	3.1276E-05
10	1.8472E-04	1.7269E-04	1.9732E-04	66	2.3852E-05	1.7938E-05	2.9035E-05
11	1.8142E-04	1.6940E-04	1.9401E-04	67	2.2002E-05	1.6384E-05	2.6850E-05
12	1.7813E-04	1.6612E-04	1.9070E-04	68	2.0216E-05	1.4903E-05	2.4725E-05
13	1.7484E-04	1.6285E-04	1.8740E-04	69	1.8498E-05	1.3498E-05	2.2667E-05
14	1.7158E-04	1.5962E-04	1.8411E-04	70	1.6853E-05	1.2170E-05	2.0682E-05
15	1.6835E-04	1.5643E-04	1.8083E-04	71	1.5284E-05	1.0921E-05	1.8777E-05
16	1.6515E-04	1.5328E-04	1.7756E-04	72	1.3793E-05	9.7517E-06	1.6956E-05
17	1.6197E-04	1.5016E-04	1.7431E-04	73	1.2383E-05	8.6618E-06	1.5225E-05
18	1.5881E-04	1.4707E-04	1.7106E-04	74	1.1054E-05	7.6500E-06	1.3587E-05
19	1.5566E-04	1.4399E-04	1.6782E-04	75	9.8082E-06	6.7149E-06	1.2047E-05
20	1.5252E-04	1.4094E-04	1.6458E-04	76	8.6463E-06	5.8562E-06	1.0608E-05
21	1.4938E-04	1.3790E-04	1.6133E-04	77	7.5716E-06	5.0743E-06	9.2735E-06
22	1.4626E-04	1.3487E-04	1.5810E-04	78	6.5860E-06	4.3683E-06	8.0487E-06
23	1.4314E-04	1.3185E-04	1.5486E-04	79	5.6901E-06	3.7355E-06	6.9356E-06
24	1.4002E-04	1.2883E-04	1.5162E-04	80	4.8823E-06	3.1726E-06	5.9335E-06
25	1.3690E-04	1.2579E-04	1.4838E-04	81	4.1601E-06	2.6761E-06	5.0393E-06
26	1.3376E-04	1.2275E-04	1.4515E-04	82	3.5204E-06	2.2420E-06	4.2487E-06
27	1.3063E-04	1.1969E-04	1.4191E-04	83	2.9593E-06	1.8660E-06	3.5572E-06
28	1.2749E-04	1.1663E-04	1.3868E-04	84	2.4719E-06	1.5430E-06	2.9586E-06
29	1.2435E-04	1.1356E-04	1.3545E-04	85	2.0527E-06	1.2686E-06	2.4459E-06
30	1.2121E-04	1.1049E-04	1.3222E-04	86	1.6971E-06	1.0388E-06	2.0126E-06
31	1.1807E-04	1.0742E-04	1.2900E-04	87	1.3996E-06	8.4921E-07	1.6514E-06
32	1.1493E-04	1.0434E-04	1.2578E-04	88	1.1524E-06	6.9378E-07	1.3524E-06
33	1.1179E-04	1.0127E-04	1.2257E-04	89	9.4829E-07	5.6704E-07	1.1066E-06
34	1.0866E-04	9.8197E-05	1.1937E-04	90	7.8116E-07	4.6433E-07	9.0628E-07
35	1.0554E-04	9.5136E-05	1.1618E-04	91	6.4626E-07	3.8192E-07	7.4553E-07
36	1.0243E-04	9.2086E-05	1.1299E-04	92	5.3932E-07	3.1675E-07	6.1882E-07
37	9.9335E-05	8.9051E-05	1.0983E-04	93	4.5603E-07	2.6617E-07	5.2049E-07
38	9.6255E-05	8.6031E-05	1.0667E-04	94	3.9264E-07	2.2795E-07	4.4567E-07
39	9.3192E-05	8.3031E-05	1.0353E-04	95	3.4637E-07	2.0022E-07	3.9090E-07
40	9.0148E-05	8.0051E-05	1.0041E-04	96	3.1555E-07	1.8170E-07	3.5408E-07
41	8.7125E-05	7.7096E-05	9.7303E-05	97	2.9931E-07	1.7166E-07	3.3403E-07
42	8.4126E-05	7.4169E-05	9.4217E-05	98	2.9839E-07	1.7072E-07	3.3124E-07
43	8.1154E-05	7.1272E-05	9.1152E-05	99	3.1529E-07	1.8068E-07	3.4807E-07
44	7.8210E-05	6.8409E-05	8.8108E-05	100	3.5481E-07	2.0505E-07	3.8937E-07
45	7.5294E-05	6.5578E-05	8.5087E-05	101	4.1336E-07	2.4200E-07	4.5087E-07
46	7.2408E-05	6.2784E-05	8.2088E-05	102	4.8033E-07	2.8461E-07	5.2102E-07
47	6.9555E-05	6.0029E-05	7.9113E-05	103	5.5434E-07	3.3212E-07	5.9828E-07
48	6.6738E-05	5.7317E-05	7.6165E-05	104	6.3179E-07	3.8244E-07	6.7875E-07
49	6.3959E-05	5.4650E-05	7.3247E-05	105	7.0514E-07	4.3095E-07	7.5438E-07
50	6.1220E-05	5.2032E-05	7.0356E-05	106	7.6147E-07	4.6969E-07	8.1151E-07
51	5.8520E-05	4.9463E-05	6.7496E-05	107	7.7005E-07	4.7915E-07	8.1775E-07
52	5.5861E-05	4.6941E-05	6.4666E-05	108	7.1916E-07	4.5168E-07	7.6115E-07
53	5.3244E-05	4.4471E-05	6.1866E-05	109	4.8569E-07	3.0983E-07	5.1215E-07
54	5.0671E-05	4.2054E-05	5.9099E-05	110	1.1444E-07	7.3091E-08	1.2042E-07
55	4.8145E-05	3.9694E-05	5.6366E-05				

Table B-9. Attributable Mortality Risk Coefficients: Breast (DDREF=1)(Sv⁻¹)

Age	General	Males	Females	Age	General	Males	Females
0	1.1042E-02	0.0000E+00	2.2646E-02	56	1.0038E-03	0.0000E+00	1.9746E-03
1	1.1182E-02	0.0000E+00	2.2903E-02	57	9.7004E-04	0.0000E+00	1.9023E-03
2	1.1193E-02	0.0000E+00	2.2922E-02	58	9.3630E-04	0.0000E+00	1.8298E-03
3	1.1200E-02	0.0000E+00	2.2935E-02	59	9.0149E-04	0.0000E+00	1.7553E-03
4	1.1206E-02	0.0000E+00	2.2945E-02	60	8.6679E-04	0.0000E+00	1.6809E-03
5	1.1210E-02	0.0000E+00	2.2952E-02	61	8.3303E-04	0.0000E+00	1.6083E-03
6	1.1214E-02	0.0000E+00	2.2959E-02	62	7.9897E-04	0.0000E+00	1.5352E-03
7	1.1218E-02	0.0000E+00	2.2965E-02	63	7.6461E-04	0.0000E+00	1.4615E-03
8	1.1221E-02	0.0000E+00	2.2971E-02	64	7.3074E-04	0.0000E+00	1.3889E-03
9	1.1224E-02	0.0000E+00	2.2976E-02	65	6.9677E-04	0.0000E+00	1.3162E-03
10	1.1227E-02	0.0000E+00	2.2980E-02	66	6.6277E-04	0.0000E+00	1.2437E-03
11	1.1229E-02	0.0000E+00	2.2984E-02	67	6.2963E-04	0.0000E+00	1.1730E-03
12	1.1231E-02	0.0000E+00	2.2988E-02	68	5.9686E-04	0.0000E+00	1.1035E-03
13	1.1233E-02	0.0000E+00	2.2992E-02	69	5.6424E-04	0.0000E+00	1.0346E-03
14	1.1237E-02	0.0000E+00	2.2996E-02	70	5.3124E-04	0.0000E+00	9.657E-04
15	1.1242E-02	0.0000E+00	2.3001E-02	71	4.9769E-04	0.0000E+00	8.9612E-04
16	1.1248E-02	0.0000E+00	2.3007E-02	72	4.6362E-04	0.0000E+00	8.2642E-04
17	1.1254E-02	0.0000E+00	2.3012E-02	73	4.2920E-04	0.0000E+00	7.5696E-04
18	1.1261E-02	0.0000E+00	2.3016E-02	74	3.9528E-04	0.0000E+00	6.8939E-04
19	1.1267E-02	0.0000E+00	2.3016E-02	75	3.6208E-04	0.0000E+00	6.2417E-04
20	8.0506E-03	0.0000E+00	1.6437E-02	76	3.2966E-04	0.0000E+00	5.6142E-04
21	4.8314E-03	0.0000E+00	9.8581E-03	77	2.9740E-04	0.0000E+00	5.0008E-04
22	4.8313E-03	0.0000E+00	9.8511E-03	78	2.6572E-04	0.0000E+00	4.4097E-04
23	4.8292E-03	0.0000E+00	9.8399E-03	79	2.3600E-04	0.0000E+00	3.8639E-04
24	4.8258E-03	0.0000E+00	9.8258E-03	80	2.0850E-04	0.0000E+00	3.3669E-04
25	4.8213E-03	0.0000E+00	9.8096E-03	81	1.8245E-04	0.0000E+00	2.9054E-04
26	4.8144E-03	0.0000E+00	9.7888E-03	82	1.5798E-04	0.0000E+00	2.4799E-04
27	4.8041E-03	0.0000E+00	9.7614E-03	83	1.3548E-04	0.0000E+00	2.0957E-04
28	4.7909E-03	0.0000E+00	9.7284E-03	84	1.1436E-04	0.0000E+00	1.7429E-04
29	4.7758E-03	0.0000E+00	9.6919E-03	85	9.5036E-05	0.0000E+00	1.4269E-04
30	4.7587E-03	0.0000E+00	9.6513E-03	86	7.8722E-05	0.0000E+00	1.1645E-04
31	4.7373E-03	0.0000E+00	9.6023E-03	87	6.5557E-05	0.0000E+00	9.5545E-05
32	4.7120E-03	0.0000E+00	9.5457E-03	88	5.4487E-05	0.0000E+00	7.8249E-05
33	4.6841E-03	0.0000E+00	9.4838E-03	89	4.5241E-05	0.0000E+00	6.4024E-05
34	4.6522E-03	0.0000E+00	9.4140E-03	90	3.7591E-05	0.0000E+00	5.2436E-05
35	4.6169E-03	0.0000E+00	9.3375E-03	91	3.1359E-05	0.0000E+00	4.3135E-05
36	4.5790E-03	0.0000E+00	9.2556E-03	92	2.6381E-05	0.0000E+00	3.5804E-05
37	4.5386E-03	0.0000E+00	9.1685E-03	93	2.2481E-05	0.0000E+00	3.0114E-05
38	4.4935E-03	0.0000E+00	9.0720E-03	94	1.9505E-05	0.0000E+00	2.5786E-05
39	4.4404E-03	0.0000E+00	8.9591E-03	95	1.7335E-05	0.0000E+00	2.2616E-05
40	2.9221E-03	0.0000E+00	5.8918E-03	96	1.5908E-05	0.0000E+00	2.0486E-05
41	1.4408E-03	0.0000E+00	2.9030E-03	97	1.5194E-05	0.0000E+00	1.9327E-05
42	1.4184E-03	0.0000E+00	2.8557E-03	98	1.5243E-05	0.0000E+00	1.9165E-05
43	1.3948E-03	0.0000E+00	2.8059E-03	99	1.6195E-05	0.0000E+00	2.0139E-05
44	1.3696E-03	0.0000E+00	2.7527E-03	100	1.8305E-05	0.0000E+00	2.2528E-05
45	1.3421E-03	0.0000E+00	2.6948E-03	101	2.1402E-05	0.0000E+00	2.6087E-05
46	1.3138E-03	0.0000E+00	2.6352E-03	102	2.4957E-05	0.0000E+00	3.0145E-05
47	1.2851E-03	0.0000E+00	2.5745E-03	103	2.8900E-05	0.0000E+00	3.4615E-05
48	1.2556E-03	0.0000E+00	2.5120E-03	104	3.3048E-05	0.0000E+00	3.9271E-05
49	1.2259E-03	0.0000E+00	2.4491E-03	105	3.7002E-05	0.0000E+00	4.3647E-05
50	1.1960E-03	0.0000E+00	2.3855E-03	106	4.0079E-05	0.0000E+00	4.6952E-05
51	1.1654E-03	0.0000E+00	2.3203E-03	107	4.0648E-05	0.0000E+00	4.7313E-05
52	1.1344E-03	0.0000E+00	2.2540E-03	108	3.8063E-05	0.0000E+00	4.4039E-05
53	1.1025E-03	0.0000E+00	2.1860E-03	109	2.5756E-05	0.0000E+00	2.9632E-05
54	1.0699E-03	0.0000E+00	2.1162E-03	110	6.0877E-06	0.0000E+00	6.9670E-06
55	1.0371E-03	0.0000E+00	2.0461E-03				

Table B-10. Attributable Mortality Risk Coefficients: Ovary (DDREF=2)(Sv⁻¹)

Age	General	Males	Females	Age	General	Males	Females
0	3.1184E-03	0.0000E+00	6.3958E-03	56	1.0220E-03	0.0000E+00	2.0104E-03
1	3.1581E-03	0.0000E+00	6.4680E-03	57	9.8438E-04	0.0000E+00	1.9304E-03
2	3.1608E-03	0.0000E+00	6.4731E-03	58	9.4664E-04	0.0000E+00	1.8501E-03
3	3.1627E-03	0.0000E+00	6.4764E-03	59	9.0924E-04	0.0000E+00	1.7704E-03
4	3.1640E-03	0.0000E+00	6.4787E-03	60	8.6993E-04	0.0000E+00	1.6870E-03
5	3.1650E-03	0.0000E+00	6.4802E-03	61	8.2879E-04	0.0000E+00	1.6001E-03
6	3.1657E-03	0.0000E+00	6.4811E-03	62	7.8799E-04	0.0000E+00	1.5141E-03
7	3.1660E-03	0.0000E+00	6.4814E-03	63	7.4820E-04	0.0000E+00	1.4302E-03
8	3.1662E-03	0.0000E+00	6.4814E-03	64	7.0873E-04	0.0000E+00	1.3471E-03
9	3.1664E-03	0.0000E+00	6.4816E-03	65	6.6724E-04	0.0000E+00	1.2604E-03
10	2.8319E-03	0.0000E+00	5.7966E-03	66	6.2454E-04	0.0000E+00	1.1719E-03
11	2.4973E-03	0.0000E+00	5.1116E-03	67	5.8219E-04	0.0000E+00	1.0846E-03
12	2.4971E-03	0.0000E+00	5.1111E-03	68	5.3901E-04	0.0000E+00	9.9653E-04
13	2.4969E-03	0.0000E+00	5.1106E-03	69	4.9832E-04	0.0000E+00	9.1374E-04
14	2.4971E-03	0.0000E+00	5.1104E-03	70	4.5996E-04	0.0000E+00	8.3602E-04
15	2.4976E-03	0.0000E+00	5.1103E-03	71	4.1995E-04	0.0000E+00	7.5615E-04
16	2.4984E-03	0.0000E+00	5.1105E-03	72	3.7951E-04	0.0000E+00	6.7650E-04
17	2.4998E-03	0.0000E+00	5.1115E-03	73	3.3998E-04	0.0000E+00	5.9961E-04
18	2.5016E-03	0.0000E+00	5.1130E-03	74	3.0069E-04	0.0000E+00	5.2442E-04
19	2.5032E-03	0.0000E+00	5.1137E-03	75	2.6237E-04	0.0000E+00	4.5229E-04
20	2.3172E-03	0.0000E+00	4.7311E-03	76	2.2820E-04	0.0000E+00	3.8863E-04
21	2.1311E-03	0.0000E+00	4.3484E-03	77	1.9637E-04	0.0000E+00	3.3020E-04
22	2.1327E-03	0.0000E+00	4.3486E-03	78	1.6401E-04	0.0000E+00	2.7218E-04
23	2.1342E-03	0.0000E+00	4.3487E-03	79	1.3537E-04	0.0000E+00	2.2163E-04
24	2.1353E-03	0.0000E+00	4.3476E-03	80	1.1090E-04	0.0000E+00	1.7909E-04
25	2.1358E-03	0.0000E+00	4.3456E-03	81	8.8793E-05	0.0000E+00	1.4140E-04
26	2.1359E-03	0.0000E+00	4.3428E-03	82	7.1377E-05	0.0000E+00	1.1204E-04
27	2.1357E-03	0.0000E+00	4.3396E-03	83	5.9322E-05	0.0000E+00	9.1764E-05
28	2.1348E-03	0.0000E+00	4.3349E-03	84	5.0242E-05	0.0000E+00	7.6569E-05
29	2.1329E-03	0.0000E+00	4.3285E-03	85	4.2130E-05	0.0000E+00	6.3255E-05
30	1.9912E-03	0.0000E+00	4.0384E-03	86	3.5044E-05	0.0000E+00	5.1837E-05
31	1.8489E-03	0.0000E+00	3.7477E-03	87	2.9184E-05	0.0000E+00	4.2533E-05
32	1.8443E-03	0.0000E+00	3.7361E-03	88	2.4256E-05	0.0000E+00	3.4833E-05
33	1.8378E-03	0.0000E+00	3.7211E-03	89	2.0139E-05	0.0000E+00	2.8501E-05
34	1.8307E-03	0.0000E+00	3.7046E-03	90	1.6734E-05	0.0000E+00	2.3342E-05
35	1.8225E-03	0.0000E+00	3.6858E-03	91	1.3960E-05	0.0000E+00	1.9202E-05
36	1.8120E-03	0.0000E+00	3.6626E-03	92	1.1744E-05	0.0000E+00	1.5938E-05
37	1.8010E-03	0.0000E+00	3.6383E-03	93	1.0008E-05	0.0000E+00	1.3406E-05
38	1.7881E-03	0.0000E+00	3.6101E-03	94	8.6827E-06	0.0000E+00	1.1479E-05
39	1.7720E-03	0.0000E+00	3.5753E-03	95	7.7168E-06	0.0000E+00	1.0068E-05
40	1.6050E-03	0.0000E+00	3.2361E-03	96	7.0815E-06	0.0000E+00	9.1197E-06
41	1.4386E-03	0.0000E+00	2.8987E-03	97	6.7636E-06	0.0000E+00	8.6034E-06
42	1.4192E-03	0.0000E+00	2.8574E-03	98	6.7858E-06	0.0000E+00	8.5314E-06
43	1.3985E-03	0.0000E+00	2.8133E-03	99	7.2094E-06	0.0000E+00	8.9650E-06
44	1.3772E-03	0.0000E+00	2.7680E-03	100	8.1485E-06	0.0000E+00	1.0029E-05
45	1.3550E-03	0.0000E+00	2.7207E-03	101	9.5273E-06	0.0000E+00	1.1613E-05
46	1.3315E-03	0.0000E+00	2.6707E-03	102	1.1110E-05	0.0000E+00	1.3420E-05
47	1.3075E-03	0.0000E+00	2.6194E-03	103	1.2865E-05	0.0000E+00	1.5409E-05
48	1.2822E-03	0.0000E+00	2.5653E-03	104	1.4712E-05	0.0000E+00	1.7482E-05
49	1.2541E-03	0.0000E+00	2.5055E-03	105	1.6472E-05	0.0000E+00	1.9430E-05
50	1.2254E-03	0.0000E+00	2.4441E-03	106	1.7842E-05	0.0000E+00	2.0901E-05
51	1.1960E-03	0.0000E+00	2.3811E-03	107	1.8095E-05	0.0000E+00	2.1062E-05
52	1.1632E-03	0.0000E+00	2.3113E-03	108	1.6944E-05	0.0000E+00	1.9604E-05
53	1.1289E-03	0.0000E+00	2.2384E-03	109	1.1466E-05	0.0000E+00	1.3191E-05
54	1.0947E-03	0.0000E+00	2.1654E-03	110	2.7100E-06	0.0000E+00	3.1014E-06
55	1.0590E-03	0.0000E+00	2.0892E-03				

Table B-11. Attributable Mortality Risk Coefficients: Bladder (DDREF=2)(Sv⁻¹)

Age	General	Males	Females	Age	General	Males	Females
0	3.0187E-03	4.2171E-03	1.7593E-03	56	2.4711E-03	3.3240E-03	1.6461E-03
1	3.0572E-03	4.2766E-03	1.7792E-03	57	2.4384E-03	3.2798E-03	1.6298E-03
2	3.0601E-03	4.2809E-03	1.7807E-03	58	2.4042E-03	3.2353E-03	1.6111E-03
3	3.0620E-03	4.2840E-03	1.7817E-03	59	2.3647E-03	3.1835E-03	1.5893E-03
4	3.0635E-03	4.2864E-03	1.7824E-03	60	2.3196E-03	3.1218E-03	1.5661E-03
5	3.0647E-03	4.2883E-03	1.7830E-03	61	2.2688E-03	3.0481E-03	1.5436E-03
6	3.0659E-03	4.2902E-03	1.7836E-03	62	2.2139E-03	2.9688E-03	1.5182E-03
7	3.0669E-03	4.2919E-03	1.7841E-03	63	2.1565E-03	2.8872E-03	1.4904E-03
8	3.0678E-03	4.2933E-03	1.7845E-03	64	2.0929E-03	2.7938E-03	1.4616E-03
9	3.0686E-03	4.2947E-03	1.7849E-03	65	2.0236E-03	2.6932E-03	1.4283E-03
10	2.9815E-03	4.1932E-03	1.7130E-03	66	1.9507E-03	2.5925E-03	1.3882E-03
11	2.8943E-03	4.0916E-03	1.6410E-03	67	1.8727E-03	2.4861E-03	1.3433E-03
12	2.8949E-03	4.0924E-03	1.6413E-03	68	1.7905E-03	2.3702E-03	1.2985E-03
13	2.8956E-03	4.0935E-03	1.6416E-03	69	1.7062E-03	2.2510E-03	1.2520E-03
14	2.8966E-03	4.0954E-03	1.6420E-03	70	1.6176E-03	2.1289E-03	1.1996E-03
15	2.8980E-03	4.0982E-03	1.6425E-03	71	1.5235E-03	1.9964E-03	1.1449E-03
16	2.9000E-03	4.1021E-03	1.6431E-03	72	1.4249E-03	1.8605E-03	1.0840E-03
17	2.9024E-03	4.1069E-03	1.6439E-03	73	1.3242E-03	1.7332E-03	1.0119E-03
18	2.9051E-03	4.1126E-03	1.6447E-03	74	1.2215E-03	1.6001E-03	9.3983E-04
19	2.9081E-03	4.1188E-03	1.6455E-03	75	1.1126E-03	1.4458E-03	8.7147E-04
20	2.8680E-03	3.9703E-03	1.7197E-03	76	1.0048E-03	1.2932E-03	8.0207E-04
21	2.8280E-03	3.8218E-03	1.7940E-03	77	9.0397E-04	1.1524E-03	7.3468E-04
22	2.8314E-03	3.8289E-03	1.7950E-03	78	8.0406E-04	1.0128E-03	6.6637E-04
23	2.8350E-03	3.8363E-03	1.7960E-03	79	7.0664E-04	8.8480E-04	5.9310E-04
24	2.8385E-03	3.8439E-03	1.7969E-03	80	6.1850E-04	7.7423E-04	5.2275E-04
25	2.8421E-03	3.8514E-03	1.7977E-03	81	5.4140E-04	6.8054E-04	4.5897E-04
26	2.8455E-03	3.8588E-03	1.7985E-03	82	4.7088E-04	5.9354E-04	4.0100E-04
27	2.8489E-03	3.8660E-03	1.7993E-03	83	4.0685E-04	5.0596E-04	3.5266E-04
28	2.8520E-03	3.8727E-03	1.8001E-03	84	3.5016E-04	4.2700E-04	3.0989E-04
29	2.8548E-03	3.8789E-03	1.8007E-03	85	3.0281E-04	3.6427E-04	2.7200E-04
30	2.8795E-03	3.8499E-03	1.8819E-03	86	2.5767E-04	3.0847E-04	2.3333E-04
31	2.9043E-03	3.8206E-03	1.9633E-03	87	2.1051E-04	2.5216E-04	1.9145E-04
32	2.9065E-03	3.8256E-03	1.9636E-03	88	1.7174E-04	2.0601E-04	1.5679E-04
33	2.9083E-03	3.8300E-03	1.9639E-03	89	1.4005E-04	1.6838E-04	1.2829E-04
34	2.9105E-03	3.8352E-03	1.9641E-03	90	1.1436E-04	1.3788E-04	1.0507E-04
35	2.9128E-03	3.8410E-03	1.9638E-03	91	9.3797E-05	1.1341E-04	8.6434E-05
36	2.9144E-03	3.8452E-03	1.9638E-03	92	7.7615E-05	9.4054E-05	7.1743E-05
37	2.9155E-03	3.8485E-03	1.9637E-03	93	6.5081E-05	7.9035E-05	6.0343E-05
38	2.9163E-03	3.8518E-03	1.9632E-03	94	5.5572E-05	6.7688E-05	5.1670E-05
39	2.9164E-03	3.8542E-03	1.9620E-03	95	4.8619E-05	5.9453E-05	4.5319E-05
40	2.7771E-03	3.6898E-03	1.8496E-03	96	4.3935E-05	5.3955E-05	4.1051E-05
41	2.6382E-03	3.5248E-03	1.7385E-03	97	4.1346E-05	5.0974E-05	3.8726E-05
42	2.6373E-03	3.5251E-03	1.7376E-03	98	4.0917E-05	5.0694E-05	3.8402E-05
43	2.6350E-03	3.5240E-03	1.7356E-03	99	4.2958E-05	5.3651E-05	4.0354E-05
44	2.6317E-03	3.5208E-03	1.7337E-03	100	4.8094E-05	6.0888E-05	4.5141E-05
45	2.6284E-03	3.5174E-03	1.7323E-03	101	5.5790E-05	7.1859E-05	5.2272E-05
46	2.6252E-03	3.5143E-03	1.7311E-03	102	6.4554E-05	8.4512E-05	6.0405E-05
47	2.6204E-03	3.5096E-03	1.7284E-03	103	7.4192E-05	9.8618E-05	6.9362E-05
48	2.6122E-03	3.5003E-03	1.7236E-03	104	8.4217E-05	1.1356E-04	7.8691E-05
49	2.6032E-03	3.4893E-03	1.7190E-03	105	9.3626E-05	1.2797E-04	8.7460E-05
50	2.5935E-03	3.4783E-03	1.7136E-03	106	1.0073E-04	1.3947E-04	9.4083E-05
51	2.5797E-03	3.4621E-03	1.7053E-03	107	1.0149E-04	1.4228E-04	9.4807E-05
52	2.5629E-03	3.4406E-03	1.6967E-03	108	9.4469E-05	1.3412E-04	8.8244E-05
53	2.5446E-03	3.4175E-03	1.6868E-03	109	6.3645E-05	9.2001E-05	5.9377E-05
54	2.5244E-03	3.3940E-03	1.6739E-03	110	1.4938E-05	2.1704E-05	1.3960E-05
55	2.5006E-03	3.3643E-03	1.6603E-03				

Table B-12. Attributable Mortality Risk Coefficients: Kidney (DDREF=2)(Sv⁻¹)

Age	General	Males	Females	Age	General	Males	Females
0	6.7552E-04	8.2322E-04	5.2029E-04	56	4.8417E-04	5.7529E-04	3.9604E-04
1	6.8402E-04	8.3475E-04	5.2604E-04	57	4.6750E-04	5.5435E-04	3.8404E-04
2	6.8455E-04	8.3550E-04	5.2635E-04	58	4.4997E-04	5.3260E-04	3.7111E-04
3	6.8489E-04	8.3605E-04	5.2651E-04	59	4.3222E-04	5.1009E-04	3.5848E-04
4	6.8512E-04	8.3643E-04	5.2660E-04	60	4.1426E-04	4.8628E-04	3.4661E-04
5	6.8528E-04	8.3667E-04	5.2671E-04	61	3.9591E-04	4.6278E-04	3.3369E-04
6	6.8542E-04	8.3688E-04	5.2678E-04	62	3.7634E-04	4.3889E-04	3.1869E-04
7	6.8551E-04	8.3710E-04	5.2678E-04	63	3.5548E-04	4.1295E-04	3.0310E-04
8	6.8562E-04	8.3732E-04	5.2677E-04	64	3.3509E-04	3.8787E-04	2.8756E-04
9	6.8571E-04	8.3753E-04	5.2675E-04	65	3.1507E-04	3.6387E-04	2.7168E-04
10	6.8574E-04	8.3763E-04	5.2672E-04	66	2.9524E-04	3.3925E-04	2.5667E-04
11	6.8570E-04	8.3764E-04	5.2665E-04	67	2.7457E-04	3.1358E-04	2.4091E-04
12	6.8569E-04	8.3766E-04	5.2660E-04	68	2.5361E-04	2.8805E-04	2.2438E-04
13	6.8569E-04	8.3769E-04	5.2658E-04	69	2.3357E-04	2.6351E-04	2.0861E-04
14	6.8571E-04	8.3783E-04	5.2652E-04	70	2.1339E-04	2.3913E-04	1.9235E-04
15	6.8583E-04	8.3819E-04	5.2644E-04	71	1.9441E-04	2.1751E-04	1.7593E-04
16	6.8609E-04	8.3879E-04	5.2645E-04	72	1.7727E-04	2.0000E-04	1.5948E-04
17	6.8644E-04	8.3951E-04	5.2652E-04	73	1.5947E-04	1.8027E-04	1.4359E-04
18	6.8683E-04	8.4033E-04	5.2659E-04	74	1.4005E-04	1.5641E-04	1.2788E-04
19	6.8730E-04	8.4129E-04	5.2671E-04	75	1.2151E-04	1.3444E-04	1.1216E-04
20	6.8783E-04	8.4238E-04	5.2683E-04	76	1.0540E-04	1.1565E-04	9.8193E-05
21	6.8835E-04	8.4357E-04	5.2685E-04	77	9.0927E-05	9.8634E-05	8.5675E-05
22	6.8882E-04	8.4475E-04	5.2680E-04	78	7.7733E-05	8.3089E-05	7.4200E-05
23	6.8921E-04	8.4594E-04	5.2659E-04	79	6.5296E-05	6.9749E-05	6.2458E-05
24	6.8952E-04	8.4704E-04	5.2632E-04	80	5.4699E-05	5.8957E-05	5.2081E-05
25	6.8974E-04	8.4790E-04	5.2609E-04	81	4.6882E-05	5.0472E-05	4.4755E-05
26	6.8992E-04	8.4863E-04	5.2593E-04	82	3.9825E-05	4.3445E-05	3.7762E-05
27	6.9010E-04	8.4929E-04	5.2582E-04	83	3.2761E-05	3.5340E-05	3.1351E-05
28	6.9002E-04	8.4976E-04	5.2539E-04	84	2.5715E-05	2.8499E-05	2.4256E-05
29	6.8960E-04	8.4981E-04	5.2468E-04	85	1.8924E-05	2.4726E-05	1.6015E-05
30	6.8907E-04	8.4954E-04	5.2408E-04	86	1.4273E-05	2.1021E-05	1.1039E-05
31	6.8843E-04	8.4896E-04	5.2357E-04	87	1.1608E-05	1.7184E-05	9.0574E-06
32	6.8747E-04	8.4791E-04	5.2290E-04	88	9.4284E-06	1.4039E-05	7.4178E-06
33	6.8608E-04	8.4622E-04	5.2198E-04	89	7.6551E-06	1.1474E-05	6.0693E-06
34	6.8413E-04	8.4370E-04	5.2080E-04	90	6.2236E-06	9.3960E-06	4.9707E-06
35	6.8190E-04	8.4077E-04	5.1947E-04	91	5.0826E-06	7.7283E-06	4.0891E-06
36	6.7923E-04	8.3740E-04	5.1769E-04	92	4.1877E-06	6.4096E-06	3.3941E-06
37	6.7602E-04	8.3342E-04	5.1545E-04	93	3.4964E-06	5.3861E-06	2.8548E-06
38	6.7249E-04	8.2888E-04	5.1314E-04	94	2.9726E-06	4.6128E-06	2.4444E-06
39	6.6804E-04	8.2289E-04	5.1045E-04	95	2.5895E-06	4.0516E-06	2.1440E-06
40	6.6270E-04	8.1543E-04	5.0748E-04	96	2.3298E-06	3.6769E-06	1.9420E-06
41	6.5724E-04	8.0771E-04	5.0452E-04	97	2.1832E-06	3.4737E-06	1.8321E-06
42	6.5104E-04	7.9884E-04	5.0126E-04	98	2.1519E-06	3.4546E-06	1.8168E-06
43	6.4394E-04	7.8896E-04	4.9723E-04	99	2.2512E-06	3.6562E-06	1.9091E-06
44	6.3610E-04	7.7856E-04	4.9223E-04	100	2.5131E-06	4.1494E-06	2.1356E-06
45	6.2736E-04	7.6683E-04	4.8680E-04	101	2.9083E-06	4.8970E-06	2.4729E-06
46	6.1820E-04	7.5450E-04	4.8113E-04	102	3.3571E-06	5.7593E-06	2.8577E-06
47	6.0833E-04	7.4131E-04	4.7490E-04	103	3.8492E-06	6.7206E-06	3.2814E-06
48	5.9770E-04	7.2713E-04	4.6818E-04	104	4.3592E-06	7.7388E-06	3.7228E-06
49	5.8625E-04	7.1174E-04	4.6104E-04	105	4.8353E-06	8.7206E-06	4.1376E-06
50	5.7294E-04	6.9347E-04	4.5307E-04	106	5.1907E-06	9.5045E-06	4.4510E-06
51	5.5879E-04	6.7454E-04	4.4409E-04	107	5.2193E-06	9.6960E-06	4.4852E-06
52	5.4523E-04	6.5695E-04	4.3496E-04	108	4.8485E-06	9.1400E-06	4.1747E-06
53	5.3112E-04	6.3784E-04	4.2624E-04	109	3.2618E-06	6.2697E-06	2.8091E-06
54	5.1602E-04	6.1674E-04	4.1751E-04	110	7.6377E-07	1.4791E-06	6.6045E-07
55	5.0032E-04	5.9580E-04	4.0744E-04				

Table B-13. Attributable Mortality Risk Coefficients: Thyroid (DDREF=2)(Sv⁻¹)

Age	General	Males	Females	Age	General	Males	Females
0	8.6903E-04	5.4325E-04	1.2114E-03	56	1.1925E-04	6.4613E-05	1.7210E-04
1	8.6775E-04	5.4262E-04	1.2085E-03	57	1.1446E-04	6.1607E-05	1.6525E-04
2	8.5617E-04	5.3485E-04	1.1929E-03	58	1.0974E-04	5.8661E-05	1.5849E-04
3	8.4435E-04	5.2692E-04	1.1769E-03	59	1.0509E-04	5.5777E-05	1.5180E-04
4	8.3239E-04	5.1891E-04	1.1608E-03	60	1.0053E-04	5.2960E-05	1.4520E-04
5	8.2033E-04	5.1083E-04	1.1445E-03	61	9.6044E-05	5.0213E-05	1.3870E-04
6	8.0825E-04	5.0273E-04	1.1282E-03	62	9.1649E-05	4.7539E-05	1.3230E-04
7	7.9613E-04	4.9461E-04	1.1119E-03	63	8.7340E-05	4.4938E-05	1.2599E-04
8	7.8398E-04	4.8646E-04	1.0955E-03	64	8.3114E-05	4.2409E-05	1.1978E-04
9	7.7180E-04	4.7829E-04	1.0791E-03	65	7.8967E-05	3.9952E-05	1.1365E-04
10	7.5958E-04	4.7010E-04	1.0626E-03	66	7.4895E-05	3.7564E-05	1.0761E-04
11	7.4734E-04	4.6188E-04	1.0462E-03	67	7.0900E-05	3.5246E-05	1.0167E-04
12	7.3511E-04	4.5367E-04	1.0297E-03	68	6.6985E-05	3.3001E-05	9.5832E-05
13	7.2292E-04	4.4550E-04	1.0133E-03	69	6.3159E-05	3.0832E-05	9.0108E-05
14	7.1082E-04	4.3742E-04	9.9693E-04	70	5.9427E-05	2.8744E-05	8.4512E-05
15	6.9883E-04	4.2946E-04	9.8062E-04	71	5.5792E-05	2.6737E-05	7.9053E-05
16	6.8695E-04	4.2159E-04	9.6439E-04	72	5.2255E-05	2.4812E-05	7.3730E-05
17	6.7517E-04	4.1382E-04	9.4822E-04	73	4.8810E-05	2.2964E-05	6.8548E-05
18	6.6346E-04	4.0612E-04	9.3210E-04	74	4.5454E-05	2.1188E-05	6.3509E-05
19	6.5180E-04	3.9848E-04	9.1599E-04	75	4.2187E-05	1.9482E-05	5.8622E-05
20	4.8015E-04	2.9317E-04	6.7493E-04	76	3.9013E-05	1.7848E-05	5.3893E-05
21	3.1431E-04	1.9168E-04	4.4191E-04	77	3.5944E-05	1.6292E-05	4.9339E-05
22	3.0854E-04	1.8792E-04	4.3387E-04	78	3.2994E-05	1.4817E-05	4.4982E-05
23	3.0277E-04	1.8417E-04	4.2583E-04	79	3.0175E-05	1.3427E-05	4.0847E-05
24	2.9700E-04	1.8042E-04	4.1778E-04	80	2.7499E-05	1.2124E-05	3.6952E-05
25	2.9122E-04	1.7666E-04	4.0974E-04	81	2.4976E-05	1.0911E-05	3.3308E-05
26	2.8542E-04	1.7288E-04	4.0170E-04	82	2.2611E-05	9.7912E-06	2.9915E-05
27	2.7961E-04	1.6909E-04	3.9366E-04	83	2.0406E-05	8.7627E-06	2.6773E-05
28	2.7379E-04	1.6528E-04	3.8562E-04	84	1.8353E-05	7.8188E-06	2.3873E-05
29	2.6796E-04	1.6147E-04	3.7759E-04	85	1.6443E-05	6.9517E-06	2.1202E-05
30	2.6213E-04	1.5765E-04	3.6956E-04	86	1.4677E-05	6.1584E-06	1.8759E-05
31	2.5630E-04	1.5382E-04	3.6154E-04	87	1.3060E-05	5.4384E-06	1.6547E-05
32	2.5046E-04	1.4998E-04	3.5352E-04	88	1.1584E-05	4.7858E-06	1.4549E-05
33	2.4462E-04	1.4615E-04	3.4552E-04	89	1.0241E-05	4.1968E-06	1.2751E-05
34	2.3879E-04	1.4231E-04	3.3754E-04	90	9.0288E-06	3.6700E-06	1.1145E-05
35	2.3297E-04	1.3848E-04	3.2957E-04	91	7.9528E-06	3.2064E-06	9.7353E-06
36	2.2716E-04	1.3466E-04	3.2163E-04	92	7.0180E-06	2.8064E-06	8.5223E-06
37	2.2138E-04	1.3086E-04	3.1372E-04	93	6.2173E-06	2.4678E-06	7.4904E-06
38	2.1562E-04	1.2706E-04	3.0584E-04	94	5.5387E-06	2.1864E-06	6.6183E-06
39	2.0988E-04	1.2329E-04	2.9799E-04	95	4.9698E-06	1.9553E-06	5.8883E-06
40	2.0417E-04	1.1954E-04	2.9018E-04	96	4.5008E-06	1.7672E-06	5.2877E-06
41	1.9849E-04	1.1581E-04	2.8240E-04	97	4.1189E-06	1.6134E-06	4.8004E-06
42	1.9284E-04	1.1210E-04	2.7466E-04	98	3.8187E-06	1.4909E-06	4.4175E-06
43	1.8724E-04	1.0843E-04	2.6697E-04	99	3.6001E-06	1.3990E-06	4.1361E-06
44	1.8168E-04	1.0480E-04	2.5933E-04	100	3.4690E-06	1.3395E-06	3.9604E-06
45	1.7617E-04	1.0119E-04	2.5173E-04	101	3.4402E-06	1.3176E-06	3.9048E-06
46	1.7070E-04	9.7626E-05	2.4419E-04	102	3.5404E-06	1.3440E-06	3.9970E-06
47	1.6528E-04	9.4099E-05	2.3669E-04	103	3.8158E-06	1.4371E-06	4.2861E-06
48	1.5991E-04	9.0618E-05	2.2926E-04	104	4.3417E-06	1.6288E-06	4.8525E-06
49	1.5461E-04	8.7187E-05	2.2189E-04	105	5.2391E-06	1.9712E-06	5.8259E-06
50	1.4937E-04	8.3807E-05	2.1458E-04	106	6.5180E-06	2.4706E-06	7.2120E-06
51	1.4420E-04	8.0479E-05	2.0734E-04	107	8.0574E-06	3.0735E-06	8.8746E-06
52	1.3908E-04	7.7198E-05	2.0016E-04	108	9.8545E-06	3.7787E-06	1.0808E-05
53	1.3402E-04	7.3969E-05	1.9304E-04	109	1.1858E-05	4.5670E-06	1.2955E-05
54	1.2903E-04	7.0793E-05	1.8599E-04	110	1.3921E-05	5.3818E-06	1.5154E-05
55	1.2411E-04	6.7675E-05	1.7901E-04				

Table B-14. Attributable Mortality Risk Coefficients: Leukemia (DDREF=2)(Sv⁻¹)

Age	General	Males	Females	Age	General	Males	Females
0	7.3754E-03	8.1542E-03	6.5570E-03	56	4.8792E-03	5.2294E-03	4.5404E-03
1	7.5543E-03	8.4145E-03	6.6527E-03	57	4.6392E-03	4.9822E-03	4.3096E-03
2	7.5322E-03	8.3847E-03	6.6388E-03	58	4.4160E-03	4.7585E-03	4.0892E-03
3	7.3855E-03	8.1778E-03	6.5553E-03	59	4.2050E-03	4.5498E-03	3.8784E-03
4	7.2153E-03	7.9377E-03	6.4586E-03	60	4.0151E-03	4.3614E-03	3.6899E-03
5	7.0626E-03	7.7290E-03	6.3645E-03	61	3.8534E-03	4.2072E-03	3.5242E-03
6	7.0177E-03	7.6516E-03	6.3539E-03	62	3.7148E-03	4.0835E-03	3.3750E-03
7	7.1385E-03	7.8131E-03	6.4320E-03	63	3.6129E-03	3.9962E-03	3.2636E-03
8	7.3594E-03	8.1275E-03	6.5550E-03	64	3.5409E-03	3.9342E-03	3.1867E-03
9	7.6013E-03	8.4690E-03	6.6927E-03	65	3.4858E-03	3.8905E-03	3.1259E-03
10	5.1868E-03	5.9127E-03	4.4268E-03	66	3.4492E-03	3.8656E-03	3.0842E-03
11	2.6202E-03	3.1642E-03	2.0507E-03	67	3.4240E-03	3.8495E-03	3.0569E-03
12	2.6167E-03	3.1478E-03	2.0608E-03	68	3.4056E-03	3.8361E-03	3.0401E-03
13	2.6227E-03	3.1365E-03	2.0848E-03	69	3.3912E-03	3.8265E-03	3.0284E-03
14	2.6511E-03	3.1571E-03	2.1216E-03	70	3.3750E-03	3.8151E-03	3.0152E-03
15	2.7014E-03	3.2116E-03	2.1676E-03	71	3.3592E-03	3.7933E-03	3.0117E-03
16	2.7751E-03	3.2891E-03	2.2377E-03	72	3.3431E-03	3.7634E-03	3.0143E-03
17	2.8646E-03	3.3746E-03	2.3318E-03	73	3.3267E-03	3.7467E-03	3.0059E-03
18	2.9696E-03	3.4739E-03	2.4432E-03	74	3.3023E-03	3.7334E-03	2.9816E-03
19	3.0916E-03	3.5988E-03	2.5627E-03	75	3.2643E-03	3.6959E-03	2.9519E-03
20	3.6964E-03	4.3470E-03	3.0185E-03	76	3.2061E-03	3.6374E-03	2.9030E-03
21	4.3532E-03	5.1567E-03	3.5172E-03	77	3.1402E-03	3.5836E-03	2.8379E-03
22	4.5633E-03	5.3834E-03	3.7111E-03	78	3.0562E-03	3.5172E-03	2.7522E-03
23	4.8008E-03	5.6382E-03	3.9319E-03	79	2.9359E-03	3.4043E-03	2.6374E-03
24	5.0618E-03	5.9257E-03	4.1666E-03	80	2.7990E-03	3.2576E-03	2.5171E-03
25	5.3462E-03	6.2469E-03	4.4144E-03	81	2.6501E-03	3.1027E-03	2.3820E-03
26	5.6490E-03	6.5925E-03	4.6742E-03	82	2.4992E-03	2.9421E-03	2.2469E-03
27	5.9750E-03	6.9702E-03	4.9481E-03	83	2.3569E-03	2.8013E-03	2.1139E-03
28	6.3289E-03	7.3862E-03	5.2391E-03	84	2.2142E-03	2.6630E-03	1.9790E-03
29	6.7054E-03	7.8327E-03	5.5449E-03	85	2.0345E-03	2.4899E-03	1.8061E-03
30	5.8302E-03	7.0990E-03	4.5257E-03	86	1.8439E-03	2.2964E-03	1.6270E-03
31	4.8255E-03	6.2421E-03	3.3706E-03	87	1.6721E-03	2.1020E-03	1.4755E-03
32	5.1086E-03	6.6162E-03	3.5620E-03	88	1.5052E-03	1.9844E-03	1.2962E-03
33	5.4032E-03	7.0077E-03	3.7591E-03	89	1.3568E-03	1.8779E-03	1.1404E-03
34	5.7074E-03	7.4098E-03	3.9649E-03	90	1.2136E-03	1.7790E-03	9.9031E-04
35	6.0190E-03	7.8212E-03	4.1764E-03	91	1.0610E-03	1.5916E-03	8.6179E-04
36	6.3358E-03	8.2394E-03	4.3916E-03	92	9.2363E-04	1.4026E-03	7.5253E-04
37	6.6526E-03	8.6561E-03	4.6089E-03	93	8.1474E-04	1.3200E-03	6.4320E-04
38	6.9654E-03	9.0692E-03	4.8219E-03	94	7.3632E-04	1.2044E-03	5.8559E-04
39	7.2690E-03	9.4734E-03	5.0256E-03	95	6.6847E-04	1.1060E-03	5.3515E-04
40	6.6280E-03	7.9955E-03	5.2382E-03	96	6.1035E-04	1.0229E-03	4.9160E-04
41	5.8978E-03	6.3524E-03	5.4364E-03	97	5.6044E-04	9.5126E-04	4.5413E-04
42	6.0712E-03	6.5441E-03	5.5921E-03	98	5.1794E-04	8.8997E-04	4.2224E-04
43	6.2188E-03	6.7064E-03	5.7255E-03	99	4.8239E-04	8.3842E-04	3.9570E-04
44	6.3322E-03	6.8274E-03	5.8321E-03	100	4.5366E-04	7.9665E-04	3.7452E-04
45	6.4063E-03	6.9043E-03	5.9043E-03	101	4.3218E-04	7.6553E-04	3.5922E-04
46	6.4424E-03	6.9379E-03	5.9441E-03	102	4.1914E-04	7.4731E-04	3.5091E-04
47	6.4377E-03	6.9246E-03	5.9492E-03	103	4.1701E-04	7.4651E-04	3.5186E-04
48	6.3912E-03	6.8652E-03	5.9168E-03	104	4.3020E-04	7.7143E-04	3.6594E-04
49	6.3043E-03	6.7638E-03	5.8459E-03	105	4.6614E-04	8.3628E-04	3.9967E-04
50	6.1779E-03	6.6207E-03	5.7375E-03	106	5.3666E-04	9.6439E-04	4.6331E-04
51	6.0157E-03	6.4411E-03	5.5942E-03	107	6.5789E-04	1.1888E-03	5.7084E-04
52	5.8232E-03	6.2317E-03	5.4200E-03	108	8.4424E-04	1.5405E-03	7.3492E-04
53	5.6061E-03	5.9992E-03	5.2199E-03	109	1.0752E-03	1.9791E-03	9.3915E-04
54	5.3723E-03	5.7482E-03	5.0047E-03	110	1.3532E-03	2.5103E-03	1.1860E-03
55	5.1271E-03	5.4870E-03	4.7770E-03				

Table B-15. Attributable Mortality Risk Coefficients: Residual (DDREF=2)(Sv⁻¹)

Age	General	Males	Females	Age	General	Males	Females
0	2.7008E-02	3.0296E-02	2.3553E-02	56	7.1979E-03	6.5535E-03	7.8211E-03
1	2.7348E-02	3.0718E-02	2.3815E-02	57	7.0256E-03	6.3996E-03	7.6273E-03
2	2.7368E-02	3.0745E-02	2.3830E-02	58	6.8448E-03	6.2360E-03	7.4259E-03
3	2.7381E-02	3.0761E-02	2.3839E-02	59	6.6555E-03	6.0654E-03	7.2145E-03
4	2.7388E-02	3.0771E-02	2.3844E-02	60	6.4570E-03	5.8884E-03	6.9910E-03
5	2.7390E-02	3.0775E-02	2.3845E-02	61	6.2485E-03	5.7014E-03	6.7577E-03
6	2.7392E-02	3.0777E-02	2.3846E-02	62	6.0288E-03	5.5003E-03	6.5158E-03
7	2.7392E-02	3.0779E-02	2.3846E-02	63	5.8008E-03	5.2889E-03	6.2673E-03
8	2.7392E-02	3.0780E-02	2.3845E-02	64	5.5654E-03	5.0706E-03	6.0111E-03
9	2.7391E-02	3.0779E-02	2.3844E-02	65	5.3234E-03	4.8454E-03	5.7483E-03
10	2.7460E-02	3.0827E-02	2.3935E-02	66	5.0743E-03	4.6144E-03	5.4774E-03
11	2.7527E-02	3.0872E-02	2.4026E-02	67	4.8156E-03	4.3761E-03	5.1949E-03
12	2.7520E-02	3.0862E-02	2.4022E-02	68	4.5491E-03	4.1312E-03	4.9037E-03
13	2.7514E-02	3.0854E-02	2.4018E-02	69	4.2778E-03	3.8835E-03	4.6065E-03
14	2.7508E-02	3.0849E-02	2.4012E-02	70	4.0044E-03	3.6335E-03	4.3077E-03
15	2.7505E-02	3.0849E-02	2.4006E-02	71	3.7264E-03	3.3787E-03	4.0048E-03
16	2.7504E-02	3.0855E-02	2.4001E-02	72	3.4418E-03	3.1234E-03	3.6910E-03
17	2.7506E-02	3.0866E-02	2.3996E-02	73	3.1563E-03	2.8673E-03	3.3770E-03
18	2.7512E-02	3.0884E-02	2.3991E-02	74	2.8696E-03	2.5989E-03	3.0710E-03
19	2.7519E-02	3.0907E-02	2.3986E-02	75	2.5868E-03	2.3351E-03	2.7689E-03
20	1.8081E-02	1.9225E-02	1.6889E-02	76	2.3145E-03	2.0896E-03	2.4726E-03
21	8.6374E-03	7.5250E-03	9.7948E-03	77	2.0502E-03	1.8471E-03	2.1886E-03
22	8.6394E-03	7.5319E-03	9.7902E-03	78	1.7960E-03	1.6113E-03	1.9178E-03
23	8.6412E-03	7.5387E-03	9.7850E-03	79	1.5597E-03	1.3955E-03	1.6644E-03
24	8.6423E-03	7.5456E-03	9.7785E-03	80	1.3485E-03	1.2040E-03	1.4373E-03
25	8.6424E-03	7.5518E-03	9.7707E-03	81	1.1583E-03	1.0355E-03	1.2310E-03
26	8.6412E-03	7.5569E-03	9.7615E-03	82	9.8432E-04	8.8144E-04	1.0429E-03
27	8.6381E-03	7.5603E-03	9.7504E-03	83	8.2820E-04	7.3853E-04	8.7724E-04
28	8.6330E-03	7.5615E-03	9.7373E-03	84	6.9394E-04	6.1456E-04	7.3553E-04
29	8.6266E-03	7.5615E-03	9.7230E-03	85	5.8119E-04	5.0864E-04	6.1757E-04
30	8.6654E-03	7.6005E-03	9.7603E-03	86	4.8156E-04	4.1595E-04	5.1300E-04
31	8.7023E-03	7.6382E-03	9.7951E-03	87	3.9553E-04	3.4003E-04	4.2092E-04
32	8.6897E-03	7.6333E-03	9.7734E-03	88	3.2440E-04	2.7779E-04	3.4472E-04
33	8.6741E-03	7.6252E-03	9.7489E-03	89	2.6592E-04	2.2705E-04	2.8206E-04
34	8.6553E-03	7.6141E-03	9.7210E-03	90	2.1824E-04	1.8592E-04	2.3100E-04
35	8.6339E-03	7.6009E-03	9.6901E-03	91	1.7990E-04	1.5292E-04	1.9003E-04
36	8.6105E-03	7.5859E-03	9.6569E-03	92	1.4960E-04	1.2683E-04	1.5773E-04
37	8.5838E-03	7.5680E-03	9.6201E-03	93	1.2605E-04	1.0658E-04	1.3267E-04
38	8.5531E-03	7.5465E-03	9.5788E-03	94	1.0816E-04	9.1273E-05	1.1360E-04
39	8.5177E-03	7.5206E-03	9.5323E-03	95	9.5090E-05	8.0169E-05	9.9636E-05
40	8.6306E-03	7.6887E-03	9.5879E-03	96	8.6342E-05	7.2755E-05	9.0252E-05
41	8.7368E-03	7.8504E-03	9.6363E-03	97	8.1634E-05	6.8735E-05	8.5143E-05
42	8.6834E-03	7.8085E-03	9.5699E-03	98	8.1141E-05	6.8358E-05	8.4430E-05
43	8.6248E-03	7.7629E-03	9.4968E-03	99	8.5514E-05	7.2346E-05	8.8721E-05
44	8.5605E-03	7.7118E-03	9.4176E-03	100	9.6033E-05	8.2104E-05	9.9247E-05
45	8.4885E-03	7.6517E-03	9.3319E-03	101	1.1169E-04	9.6898E-05	1.1492E-04
46	8.4103E-03	7.5861E-03	9.2392E-03	102	1.2956E-04	1.1396E-04	1.3280E-04
47	8.3258E-03	7.5165E-03	9.1377E-03	103	1.4927E-04	1.3298E-04	1.5250E-04
48	8.2346E-03	7.4403E-03	9.0295E-03	104	1.6986E-04	1.5313E-04	1.7301E-04
49	8.1367E-03	7.3582E-03	8.9136E-03	105	1.8928E-04	1.7256E-04	1.9229E-04
50	8.0314E-03	7.2712E-03	8.7874E-03	106	2.0410E-04	1.8807E-04	2.0685E-04
51	7.9176E-03	7.1753E-03	8.6532E-03	107	2.0610E-04	1.9186E-04	2.0844E-04
52	7.7937E-03	7.0694E-03	8.5085E-03	108	1.9223E-04	1.8085E-04	1.9401E-04
53	7.6584E-03	6.9553E-03	8.3493E-03	109	1.2970E-04	1.2406E-04	1.3054E-04
54	7.5122E-03	6.8304E-03	8.1790E-03	110	3.0513E-05	2.9266E-05	3.0693E-05
55	7.3589E-03	6.6962E-03	8.0037E-03				

Table B-16. Attributable Mortality Risk Coefficients: All Cancers (Sv⁻¹)

Age	General	Males	Females	Age	General	Males	Females
0	1.0764E-01	8.7708E-02	1.2859E-01	56	2.7496E-02	2.4025E-02	3.0853E-02
1	1.0908E-01	8.9075E-02	1.3004E-01	57	2.6577E-02	2.3235E-02	2.9789E-02
2	1.0913E-01	8.9109E-02	1.3011E-01	58	2.5653E-02	2.2445E-02	2.8714E-02
3	1.0903E-01	8.8943E-02	1.3007E-01	59	2.4717E-02	2.1641E-02	2.7631E-02
4	1.0888E-01	8.8729E-02	1.3000E-01	60	2.3783E-02	2.0829E-02	2.6558E-02
5	1.0874E-01	8.8535E-02	1.2991E-01	61	2.2849E-02	2.0019E-02	2.5483E-02
6	1.0871E-01	8.8468E-02	1.2991E-01	62	2.1911E-02	1.9206E-02	2.4405E-02
7	1.0884E-01	8.8637E-02	1.3000E-01	63	2.0998E-02	1.8414E-02	2.3353E-02
8	1.0906E-01	8.8956E-02	1.3012E-01	64	2.0103E-02	1.7637E-02	2.2324E-02
9	1.0931E-01	8.9299E-02	1.3025E-01	65	1.9217E-02	1.6865E-02	2.1308E-02
10	1.0791E-01	8.8128E-02	1.2862E-01	66	1.8347E-02	1.6105E-02	2.0312E-02
11	1.0636E-01	8.6759E-02	1.2688E-01	67	1.7476E-02	1.5344E-02	1.9315E-02
12	1.0634E-01	8.6728E-02	1.2688E-01	68	1.6598E-02	1.4574E-02	1.8316E-02
13	1.0634E-01	8.6708E-02	1.2689E-01	69	1.5738E-02	1.3818E-02	1.7338E-02
14	1.0637E-01	8.6731E-02	1.2692E-01	70	1.4882E-02	1.3078E-02	1.6358E-02
15	1.0643E-01	8.6807E-02	1.2696E-01	71	1.4020E-02	1.2333E-02	1.5371E-02
16	1.0653E-01	8.6922E-02	1.2704E-01	72	1.3158E-02	1.1590E-02	1.4385E-02
17	1.0666E-01	8.7062E-02	1.2714E-01	73	1.2307E-02	1.0879E-02	1.3397E-02
18	1.0681E-01	8.7229E-02	1.2725E-01	74	1.1454E-02	1.0166E-02	1.2412E-02
19	1.0699E-01	8.7434E-02	1.2738E-01	75	1.0592E-02	9.4240E-03	1.1438E-02
20	7.5513E-02	6.0283E-02	9.1377E-02	76	9.7376E-03	8.7009E-03	1.0466E-02
21	4.4054E-02	3.3135E-02	5.5415E-02	77	8.9212E-03	8.0258E-03	9.5314E-03
22	4.4279E-02	3.3393E-02	5.5589E-02	78	8.1199E-03	7.3684E-03	8.6156E-03
23	4.4529E-02	3.3679E-02	5.5786E-02	79	7.3219E-03	6.7155E-03	7.7083E-03
24	4.4798E-02	3.3997E-02	5.5990E-02	80	6.5855E-03	6.0960E-03	6.8864E-03
25	4.5087E-02	3.4346E-02	5.6200E-02	81	5.9019E-03	5.5349E-03	6.1193E-03
26	4.5388E-02	3.4717E-02	5.6414E-02	82	5.2617E-03	5.0107E-03	5.4047E-03
27	4.5702E-02	3.5114E-02	5.6627E-02	83	4.6885E-03	4.5318E-03	4.7742E-03
28	4.6035E-02	3.5544E-02	5.6846E-02	84	4.1665E-03	4.0962E-03	4.2033E-03
29	4.6383E-02	3.6000E-02	5.7071E-02	85	3.6545E-03	3.6768E-03	3.6433E-03
30	4.4111E-02	3.4216E-02	5.4285E-02	86	3.1832E-03	3.2759E-03	3.1387E-03
31	4.1699E-02	3.2300E-02	5.1350E-02	87	2.7772E-03	2.9046E-03	2.7189E-03
32	4.1918E-02	3.2664E-02	5.1412E-02	88	2.4158E-03	2.6418E-03	2.3173E-03
33	4.2135E-02	3.3036E-02	5.1459E-02	89	2.1069E-03	2.4168E-03	1.9782E-03
34	4.2346E-02	3.3408E-02	5.1495E-02	90	1.8323E-03	2.2216E-03	1.6786E-03
35	4.2549E-02	3.3783E-02	5.1512E-02	91	1.5737E-03	1.9568E-03	1.4298E-03
36	4.2740E-02	3.4154E-02	5.1509E-02	92	1.3520E-03	1.7065E-03	1.2254E-03
37	4.2914E-02	3.4512E-02	5.1485E-02	93	1.1775E-03	1.5761E-03	1.0421E-03
38	4.3061E-02	3.4854E-02	5.1424E-02	94	1.0489E-03	1.4242E-03	9.2804E-04
39	4.3171E-02	3.5169E-02	5.1314E-02	95	9.4427E-04	1.2996E-03	8.3602E-04
40	3.9144E-02	3.2598E-02	4.5796E-02	96	8.6138E-04	1.1987E-03	7.6428E-04
41	3.5033E-02	2.9841E-02	4.0301E-02	97	7.9795E-04	1.1172E-03	7.1110E-04
42	3.4966E-02	2.9886E-02	4.0114E-02	98	7.5372E-04	1.0546E-03	6.7631E-04
43	3.4852E-02	2.9884E-02	3.9878E-02	99	7.3006E-04	1.0119E-03	6.6143E-04
44	3.4679E-02	2.9819E-02	3.9587E-02	100	7.3044E-04	9.9236E-04	6.7000E-04
45	3.4439E-02	2.9688E-02	3.9229E-02	101	7.5257E-04	9.9515E-04	6.9947E-04
46	3.4134E-02	2.9492E-02	3.8804E-02	102	7.8961E-04	1.0162E-03	7.4250E-04
47	3.3759E-02	2.9222E-02	3.8311E-02	103	8.4307E-04	1.0593E-03	8.0031E-04
48	3.3315E-02	2.8887E-02	3.7747E-02	104	9.1478E-04	1.1310E-03	8.7406E-04
49	3.2806E-02	2.8491E-02	3.7112E-02	105	1.0067E-03	1.2413E-03	9.6456E-04
50	3.2227E-02	2.8023E-02	3.6409E-02	106	1.1211E-03	1.4062E-03	1.0722E-03
51	3.1580E-02	2.7484E-02	3.5638E-02	107	1.2512E-03	1.6409E-03	1.1873E-03
52	3.0866E-02	2.6887E-02	3.4793E-02	108	1.4030E-03	1.9697E-03	1.3140E-03
53	3.0091E-02	2.6239E-02	3.3876E-02	109	1.4640E-03	2.2806E-03	1.3411E-03
54	2.9268E-02	2.5544E-02	3.2910E-02	110	1.4699E-03	2.5971E-03	1.3070E-03
55	2.8400E-02	2.4801E-02	3.1900E-02				

Table B-17. Attributable Mortality Risk Coefficients: Radon Daughter Inhalation (WL⁻¹) *

Age	General	Males	Females	Age	General	Males	Females
0	2.4098E-04	3.4421E-04	1.3248E-04	56	2.4441E-04	3.7312E-04	1.1983E-04
1	2.4405E-04	3.4907E-04	1.3397E-04	57	2.3012E-04	3.5310E-04	1.1181E-04
2	2.4427E-04	3.4942E-04	1.3408E-04	58	2.1434E-04	3.3090E-04	1.0299E-04
3	2.4443E-04	3.4967E-04	1.3416E-04	59	1.9709E-04	3.0618E-04	9.3633E-05
4	2.4456E-04	3.4988E-04	1.3422E-04	60	1.8183E-04	2.8433E-04	8.5427E-05
5	2.4466E-04	3.5005E-04	1.3426E-04	61	1.7327E-04	2.7279E-04	8.0486E-05
6	2.4475E-04	3.5020E-04	1.3430E-04	62	1.6843E-04	2.6690E-04	7.7525E-05
7	2.4484E-04	3.5034E-04	1.3435E-04	63	1.6310E-04	2.6009E-04	7.4503E-05
8	2.4492E-04	3.5048E-04	1.3439E-04	64	1.5719E-04	2.5228E-04	7.1352E-05
9	2.4499E-04	3.5060E-04	1.3442E-04	65	1.5086E-04	2.4364E-04	6.8189E-05
10	2.4506E-04	3.5070E-04	1.3445E-04	66	1.4400E-04	2.3405E-04	6.4867E-05
11	2.4512E-04	3.5079E-04	1.3448E-04	67	1.3653E-04	2.2331E-04	6.1435E-05
12	2.4518E-04	3.5089E-04	1.3451E-04	68	1.2885E-04	2.1198E-04	5.8097E-05
13	2.4526E-04	3.5101E-04	1.3455E-04	69	1.2109E-04	2.0045E-04	5.4742E-05
14	2.4537E-04	3.5121E-04	1.3460E-04	70	1.1315E-04	1.8842E-04	5.1410E-05
15	2.4553E-04	3.5150E-04	1.3467E-04	71	1.0527E-04	1.7609E-04	4.8380E-05
16	2.4573E-04	3.5188E-04	1.3475E-04	72	9.7380E-05	1.6365E-04	4.5347E-05
17	2.4599E-04	3.5235E-04	1.3486E-04	73	8.9305E-05	1.5083E-04	4.2153E-05
18	2.4630E-04	3.5293E-04	1.3500E-04	74	8.1437E-05	1.3801E-04	3.9185E-05
19	2.4667E-04	3.5360E-04	1.3515E-04	75	7.3924E-05	1.2564E-04	3.6349E-05
20	2.4710E-04	3.5438E-04	1.3534E-04	76	6.6694E-05	1.1362E-04	3.3569E-05
21	2.4760E-04	3.5525E-04	1.3558E-04	77	5.9778E-05	1.0194E-04	3.0923E-05
22	2.4818E-04	3.5626E-04	1.3588E-04	78	5.3107E-05	9.0569E-05	2.8296E-05
23	2.4888E-04	3.5746E-04	1.3622E-04	79	4.6829E-05	7.9718E-05	2.5781E-05
24	2.4970E-04	3.5880E-04	1.3666E-04	80	4.1092E-05	6.9681E-05	2.3437E-05
25	2.5067E-04	3.6032E-04	1.3721E-04	81	3.5720E-05	6.0363E-05	2.1058E-05
26	2.5180E-04	3.6211E-04	1.3782E-04	82	3.0764E-05	5.1670E-05	1.8801E-05
27	2.5310E-04	3.6408E-04	1.3857E-04	83	2.6382E-05	4.3935E-05	1.6741E-05
28	2.5454E-04	3.6620E-04	1.3945E-04	84	2.2566E-05	3.7330E-05	1.4798E-05
29	2.5620E-04	3.6865E-04	1.4044E-04	85	1.9371E-05	3.1747E-05	1.3141E-05
30	2.5813E-04	3.7144E-04	1.4163E-04	86	1.6623E-05	2.7072E-05	1.1597E-05
31	2.6033E-04	3.7459E-04	1.4299E-04	87	1.4161E-05	2.3041E-05	1.0085E-05
32	2.6280E-04	3.7809E-04	1.4454E-04	88	1.2078E-05	1.9686E-05	8.7500E-06
33	2.6555E-04	3.8199E-04	1.4622E-04	89	1.0325E-05	1.6850E-05	7.6081E-06
34	2.6857E-04	3.8645E-04	1.4791E-04	90	8.6571E-06	1.4085E-05	6.5087E-06
35	2.7185E-04	3.9137E-04	1.4965E-04	91	7.2639E-06	1.1853E-05	5.5373E-06
36	2.7542E-04	3.9661E-04	1.5164E-04	92	6.3003E-06	1.0369E-05	4.8450E-06
37	2.7918E-04	4.0224E-04	1.5363E-04	93	5.4847E-06	9.1084E-06	4.2532E-06
38	2.8310E-04	4.0824E-04	1.5560E-04	94	4.7993E-06	8.0564E-06	3.7498E-06
39	2.8727E-04	4.1468E-04	1.5761E-04	95	4.2266E-06	7.1868E-06	3.3247E-06
40	2.9114E-04	4.2092E-04	1.5923E-04	96	3.7545E-06	6.4744E-06	2.9720E-06
41	2.9430E-04	4.2633E-04	1.6029E-04	97	3.3694E-06	5.8894E-06	2.6846E-06
42	2.9699E-04	4.3128E-04	1.6089E-04	98	3.0632E-06	5.4214E-06	2.4575E-06
43	2.9931E-04	4.3575E-04	1.6126E-04	99	2.8325E-06	5.0675E-06	2.2894E-06
44	3.0115E-04	4.3939E-04	1.6154E-04	100	2.6795E-06	4.8357E-06	2.1835E-06
45	3.0273E-04	4.4274E-04	1.6159E-04	101	2.6142E-06	4.7472E-06	2.1490E-06
46	3.0381E-04	4.4571E-04	1.6107E-04	102	2.6574E-06	4.8450E-06	2.2046E-06
47	3.0439E-04	4.4815E-04	1.6013E-04	103	2.8418E-06	5.1983E-06	2.3783E-06
48	3.0457E-04	4.5003E-04	1.5898E-04	104	3.2337E-06	5.9407E-06	2.7271E-06
49	3.0385E-04	4.5052E-04	1.5747E-04	105	3.9142E-06	7.2570E-06	3.3180E-06
50	3.0135E-04	4.4835E-04	1.5511E-04	106	4.8445E-06	9.1111E-06	4.1182E-06
51	2.9575E-04	4.4163E-04	1.5113E-04	107	5.9411E-06	1.1327E-05	5.0648E-06
52	2.8770E-04	4.3125E-04	1.4595E-04	108	7.2096E-06	1.3918E-05	6.1652E-06
53	2.7878E-04	4.1956E-04	1.4035E-04	109	8.6092E-06	1.6812E-05	7.3858E-06
54	2.6890E-04	4.0658E-04	1.3416E-04	110	1.0033E-05	1.9800E-05	8.6351E-06
55	2.5740E-04	3.9110E-04	1.2723E-04				

* Lung cancer mortality risk based on relative risk model, using BEIR IV (NAS91) model and K-factor (K=0.7). Assumes single exposure at given age, T_e, to 0.242 WLM. DDREF = 1.

Appendix C

**PRE-1994 EPA Radiogenic
Cancer Risk Models and Slope Factors**

[This page is blank intentionally.]

CONTENTS

Section	Page
C.1	RADIOGENIC CANCER FROM LOW-LET RADIATION C-5
C.1.1	Organ Risks C-6
C.2	RADIOGENIC CANCER RISK FROM ALPHA-PARTICLE EMITTERS C-9
C.2.1	General Approach C-9
C.2.2	Radon Decay Products C-9
C.3	EXAMPLE CALCULATIONS: EPA RADIONUCLIDE SLOPE FACTORS (1989 - 1992) C-12
C.3.1	General Information C-12
C.3.2	Illustrative Examples C-12
C.4	INTERIM 1992 REVISIONS IN DOSE AND RISK MODELS C-20
C.5	REFERENCES C-22

TABLES

Table		Page
C-1	Mortality risk coefficients for (pre-1993) EPA constrained risk model (BEIR III)	C-8
C-2	Site-specific mortality risk per unit dose (1.0E-6 per rad) for combined leukemia-bone and constrained relative risk model	C-10
C-3	Site-specific incidence risk per unit dose (1.0E-6 per rad) for combined leukemia-bone and constrained relative risk model	C-11
C-4	Reference life table data used for EPA risk estimates prior to 1994 (1970 decennial life table for U.S. population - male and female combined)	C-14
C-5	Attributable Cancer Risk from Uniform Low-LET Radiation (chronic constant dose rate to all organs)	C-15
C-6	Derivation of Attributable Cancer Risk Resulting from Chronic Exposure to Gamma Radiation from Cs-137+D Ground Contamination (1 pCi/g, 0.037 Bq/g)	C-16
C-7	Derivation of Attributable Cancer Risk Resultin from Chronic Inhalation of Pu-238 [1 pCi/y (0.037 Bq/y) constant intake rate]	C-18
C-8	Derivation of Attributable Cancer Risk Resulting from Chronic Ingestion of Sr-90 (1 pCi/y constant intake rate)	C-19
C-9	Cancer Mortality Risk (Original and Revised Values) from Lifetime Ingestion of ²²⁶ Ra or ²²⁸ Ra in Drinking Water	C-21
C-10	Cancer Mortality Risk (Previous and Revised Values) from Lifetime Ingestion of Uranium	C-22

Appendix C

PRE-1994 EPA Radiogenic Cancer Risk Models and Slope Factors

Appendix C presents a summary of the methodology previously used by EPA for estimating radiogenic cancer risk. This approach was used for development of the radionuclide slope factors prior to 1994. In 1994, EPA adopted a revised methodology for estimating radiogenic cancer risk and developing radionuclide slope factors (EPA94), as described in the main body of the text.

The models and assumptions used by EPA for estimating radiogenic cancer risk from exposure to low-LET and high-LET radiation are summarized in Sections C.1 and C.2, respectively. Additional information on these risk models may be found in Reference (EPA89). Simplified numerical examples of the methods used to derive radionuclide slope factors are presented in Section C.3. Interim revisions to the dose and risk calculations adopted in 1992 are described in Section C.4.

C.1 RADIOGENIC CANCER FROM LOW-LET RADIATION

From 1984 to 1992, EPA's estimates of cancer risks from low-LET radiation were based largely on the National Academy of Sciences BEIR III report (NAS80). These estimates of radiation risk were based on a presumed linear dose response function; a relative risk model with a lifetime expression period was assigned for all cancer sites except for leukemia and bone cancer, where an absolute risk model with a 25-year expression period was used. These risk estimates were used in the development of radionuclide slope factors prior to 1993.

More recently, important new data have become available, especially revised dosimetry and further epidemiological follow-up on the Japanese atomic bomb survivors. EPA has recently adopted a revised methodology for estimating radiogenic cancer risks (EPA94) to incorporate this new information. In addition, the revised approach utilizes more recent vital statistics for the 1980 U.S. population, in place of the 1970 U.S. vital statistics used previously. The revised methodology is summarized in Chapter 3.

For development of slope factors prior to 1992, EPA used a life table analysis to estimate the number of radiogenic cancers in an exposed population of 100,000 persons. This analysis considered not only death due to radiogenic cancer, but also the probabilities of other competing causes of death which were much larger and varied considerably with age (Bu81, Co78). For ages 0 to 110, the risk of death due to all causes was calculated by applying the 1970 mortality data from the National Center for Health Statistics (NCHS75) to a cohort of 100,000 persons. Age-dependent risk coefficients from the BEIR III report were used in the life table analysis. For relative risk estimates, EPA used age-specific cancer mortality data also provided by NCHS (NCHS73). The EPA computer program used for the life table analysis was furnished to the BEIR III

Committee by EPA and used by the Committee to prepare its risk estimates. Therefore, the population base and calculations should be essentially the same in both the BEIR III and EPA analyses.

Both absolute and relative risk models were considered to project the observed risks of most solid radiogenic cancers beyond the period of current observation. The range of estimated radiogenic cancers resulting from the choice of a particular projection model and its internal assumptions was about a factor of 3. The relative risk model was adopted as the better projection model for solid cancers, whereas the absolute risk model was selected for projecting radiogenic risk from leukemia and bone cancer. Previously, EPA had used an average of the risks calculated by the absolute and relative risk projection models (EPA84).

To estimate the radiogenic risk resulting from leukemia and bone cancer, EPA used an absolute risk model, a minimum latency period of 2 years, and a 25-year expression period. To estimate the radiogenic risk resulting from other cancers, EPA used a relative risk projection model, a 10-year minimum latency period, and the remaining balance of an exposed person's lifetime as the expression period.

BEIR III also presented estimates of excess soft tissue cancer incidence risk coefficients for specific sites, as a function of age at exposure (NAS80 Table V-14). By summing the site-specific risks, it then arrived at an estimate for the whole-body risk of cancer incidence (other than leukemia and bone cancer) (NAS80 Table V-30). Finally, by using the weighted incidence:mortality ratios (NAS80 Table V-15), the estimates of cancer incidence (other than leukemia and bone cancer) were expressed in terms of mortality to yield (for lifetime exposure) a risk estimate of about 242 and 776 cancer fatalities per million person-rad, depending on whether an absolute or a relative risk projection model, respectively, was used to estimate lifetime risk. These values were about 1.7 and 2.1 times their counterparts for the BEIR III $\overline{L-L}$ model and 4.2 and 5.2 times the $\overline{LQ-L}$ values. These models all presumed a uniform dose to all tissues at risk in the body. In practice, such uniform whole-body exposures seldom occur, particularly for ingested or inhaled radioactivity.

C.1.1 Organ Risks

Environmental exposures to radioactive materials often result in nonuniform radiation doses to body organs and tissues. In particular, depending on the chemical and physical characteristics of the radioactive material, inhalation and ingestion may result in a nonuniform distribution of radioactive materials within the body so that some organ systems receive much higher doses than others. For example, since iodine isotopes concentrate preferentially in the thyroid gland, the dose to this organ can be orders of magnitude larger than the average dose to the body.

To determine the probability that fatal cancer occurs at a particular site, EPA performed life table analyses for each cancer type using the information on cancer incidence and mortality in BEIR III (NAS80). BEIR III published incidence risk coefficients (NAS80 Table V-14) and mortality to incidence ratios (NAS80 Table V-15). These data were used in the development of EPA's risk coefficients, as described below, with the

exception of the mortality to incidence ratios for thyroid and lung cancer. Since not all forms of thyroid cancer can be induced by radiation and since, for those that are, a more reasonable mortality to incidence ratio would be 0.1 (NRC85), EPA used that value in its calculations. Lung cancer incidence and mortality showed an increasing trend between 1970 and 1980. Since incidence leads mortality, an uncorrected mortality to incidence ratio gives a low estimate of the fraction of those persons who, having been diagnosed with lung cancer, will die of that disease. Therefore, a mortality to incidence ratio of 0.94, based on long-term survival studies by the National Cancer Institute for lung cancer was used.

Risk coefficients for a site-specific relative risk model were calculated as follows:

1. Mortality risk coefficients for an absolute risk model were calculated using the site-specific incidence risk coefficients from BEIR III (NAS80, Table V-14) and mortality:incidence ratios (NAS80, Table V-15, except for thyroid and lung).
2. Following the procedure used in BEIR III, absolute risks at an absorbed dose rate of 1 mrad/y were calculated for each cancer site for males and females in each age group. A 10-year minimum latency and a 20-year plateau, i.e., a 30-year follow-up, was used for these calculations.
3. The relative risk coefficients (rad^{-1}) for each age group providing the same 30-year projected risk were then calculated. Following the BEIR III convention, the values calculated for ages 10-19 were used for ages 0-9. For consistency, EPA used this convention for all cancers including lung and breast, for which the BEIR III absolute risk coefficients are zero in the first decade. For calculating thyroid risks, the relevant age-specific mortality rate was considered to be one-tenth of the corresponding incidence rate (NRC85). A mortality to incidence ratio of 0.94, based on long-term survival studies by the National Cancer Institute for lung cancer (J. Horn, private communication), was used. For leukemia and bone cancer, the incidence and mortality risks were considered to be equal, as in BEIR III.
4. Male and female risks for lifetime expression of risk at 1 mrad/y were then calculated and combined to obtain estimates for the general population. EPA used the National Center for Health Statistics 1970 Life Table and mortality data (NCHS73,75) for these calculations. Male and female cohort estimates were combined based on a male:female sex ratio at birth of 1.0511, consistent with the expected lifetimes at birth for the 1970 male, female, and general cohort life tables.
5. The low-LET risk coefficient for bone was obtained by dividing the value for alpha particles (high-LET) in BEIR III (NAS80, Table A-27) by an RBE of 8 to obtain a low-LET value of 1.25×10^{-7} per rad-year. The risk coefficients for leukemia were obtained by subtracting the risk coefficients for bone from the risk coefficients for leukemia and bone from BEIR III (NAS80 Table V-17). EPA followed the BEIR III Committee's practice of using the absolute risk model projections for leukemia and bone cancer with the relative risk projection for all other cancers. Since the expression period for leukemia and bone cancer is 27 years, there is no difference between the number of cancers projected for a 30-year and a lifetime follow-up period.
6. Ingested iodine-131 has been reported to be only one-tenth as effective as x-rays or gamma rays in inducing thyroid cancer (NCRP85). BEIR III reported estimates of factors of 10-80 times reduction for ingested iodine-131 compared to x-rays and noted the estimates were derived primarily from animal experiments (NAS80). However, one study in rats reported that iodine-131 was just as effective as x-rays

in inducing thyroid cancer, leading a review group to select one-third as the minimum ratio of iodine-131 to x-ray effects that is compatible with both old and new data (NRC85). For this analysis, EPA employed a thyroid cancer risk coefficient for internal exposures to iodine-131 and iodine-129 which is one-third that used for gamma rays or beta radiations from other radionuclides.

- It is generally accepted that the risk estimates for individual cancer sites are less certain than is the risk estimate for all sites combined. Thus, the lifetime risks calculated for the BEIR III linear model were used as a constraint on the sum of the individual site estimates. The relative risk coefficient for each site was calculated by multiplying the coefficient for the unconstrained model for each sex by the quotient of the average risk for all age groups for the BEIR III linear, unconstrained site-specific model. The constrained risk coefficients are about one-half of the unconstrained values.

The resulting risk coefficients are presented in Table C-1.

Table C-1. Mortality risk coefficients for (pre-1993) EPA constrained risk model (BEIR III)

Cancer Type	Risk Model Type	Age at Exposure					Lethality Fraction
		0-9	10-19	20-34	35-50	50+	
Male:							
Leukemia	A	3.852	1.724	2.471	1.796	4.194	1.00
Bone	A	0.125	0.125	0.125	0.125	0.125	1.00
Thyroid	R	52.74	52.74	38.00	28.63	22.43	0.10
Breast	R	0	0	0	0	0	-
Lung	R	2.99	2.99	2.15	1.34	1.18	0.94
Esophagus	R	6.15	6.15	1.44	0.71	1.15	1.00
Stomach	R	11.71	11.71	4.20	1.76	1.70	0.75
Intestine	R	3.35	3.35	1.28	0.48	0.46	0.52
Liver	R	120.37	120.37	25.19	7.23	4.24	1.00
Pancreas	R	7.81	7.81	2.49	1.12	1.37	0.91
Urinary	R	4.14	4.14	1.38	0.59	0.39	0.37
Lymphoma	R	4.41	4.41	1.28	0.42	0.21	0.73
Other	R	1.12	1.12	1.02	0.44	0.47	0.65
Female:							
Leukemia	A	2.417	1.067	1.541	1.112	2.635	1.00
Bone	A	0.125	0.125	0.125	0.125	0.125	1.00
Thyroid	R	35.30	35.30	35.96	34.81	29.53	0.10
Breast	R	10.52	10.52	2.80	1.52	1.02	0.39
Lung	R	6.36	6.36	6.27	6.10	6.12	0.94
Esophagus	R	13.30	13.30	3.90	2.31	3.17	1.00
Stomach	R	14.15	14.15	7.08	3.19	2.60	0.78
Intestine	R	2.63	2.63	1.06	0.45	0.42	0.55
Liver	R	142.77	142.77	46.62	16.29	7.80	1.00
Pancreas	R	11.81	11.81	3.61	1.50	1.59	0.90
Urinary	R	8.10	8.10	3.41	1.63	0.96	0.46
Lymphoma	R	6.28	6.28	1.60	0.50	0.25	0.75
Other	R	0.53	0.50	0.47	0.24	0.27	0.50

Notes:

Risk model type	Coefficient units
Absolute (A)	$10^{-6} (\text{rad/y})^{-1} [10^{-4} (\text{Gy/y})^{-1}]$
Relative (R)	$10^{-3} \text{ rad}^{-1} (10^{-1} \text{ Gy}^{-1})$

Lethality fractions (mortality:incidence ratios) are from BEIR III (NAS80).

Table C-2 shows the average mortality risks per unit absorbed dose for the combined leukemia/bone and constrained relative risk models. Values are presented for males, females, and the general population (male and female combined) for age-averaged individuals exposed in five age groups. The risk, in general, decreases with increasing age at exposure. For a constant, uniform absorbed dose rate to all organs and tissues, about 60 percent of the risk is conferred by the exposures in the first 20 years of life.

The mortality to incidence ratios presented in Table C-1 were used to convert the mortality risk estimates in Table C-2 to incidence risk estimates. For leukemia and bone cancer, the incidence risks are considered to be equal as in BEIR III (NAS80). The resultant incidence risks are shown in Table C-3.

C.2 RADIOGENIC CANCER RISK FROM ALPHA-PARTICLE EMITTERS

C.2.1 General Approach

EPA evaluated the risk to specific body organs by applying an RBE of 8 for alpha radiations to the risk estimates for low dose rate, low-LET radiations; the RBE value for leukemia only was revised to 1.117 in 1992. As in the case of low-LET radiations, EPA risk estimates for high-LET radiations were based on a linear dose response function. For bone cancer and leukemia, EPA used the absolute risk projection model described in the previous section. For other cancers, relative risk projections were used.

Lifetime risk estimates for alpha doses, as a function of age, sex, and cancer site, were obtained by multiplying the appropriate entries in Table C-2 and C-3 by a factor of 8. The whole-body risks from lifetime exposure of the general population were then calculated to be $3.1 \times 10^{-3}/\text{rad}$ (mortality) and $5.0 \times 10^{-3}/\text{rad}$ (incidence).

C.2.2 Radon Decay Products

For estimating risks from radon decay products, EPA employed an epidemiological approach, based on human epidemiological data. When radon-222, a radioactive noble gas, decays, a number of short half-life radionuclides (principally polonium-218, lead-214, bismuth-214, and polonium-214) are formed. These decay products, commonly referred to as "progeny" or "daughters," readily attach to inhalable aerosol particles in air. When inhaled, the radon progeny are deposited on the surfaces of the larger bronchi of the lung. Since two of these radionuclides decay by alpha-particle emission, the bronchial epithelium is irradiated by high-LET radiation. A wealth of data indicate that a range of exposures to the bronchial epithelium of underground miners causes an increase in bronchial lung cancer, both in smoking and in nonsmoking miners, and in some members of the general public.

The epidemiological approach to estimation of radon risks makes maximal use of the extensive human epidemiological data and avoids uncertainties associated with estimating the bronchial dose delivered by the inhaled radon progeny and selection of an appropriate RBE value. On this basis, EPA employed a central risk estimate for excess radon exposure of 360 fatal lung cancers/ 10^6 working level months (WLM) and an uncertainty range of 140-720 fatal lung cancers/ 10^6 WLM (EPA89).

Table C-2. Site-specific mortality risk per unit dose (1.0E-6 per rad) for combined leukemia-bone and constrained relative risk model

Site	Age at Exposure					All
	0-9	10-19	20-34	35-50	50+	
<u>Male</u>						
Leukemia	94.68	41.86	58.46	37.52	48.64	54.19
Bone	3.07	3.04	2.96	2.61	1.45	2.47
Thyroid	8.25	8.25	5.08	2.69	0.80	4.32
Breast	0.00	0.00	0.00	0.00	0.00	0.00
Lung	145.90	146.95	107.22	61.40	22.55	84.21
Esophagus	25.57	25.76	6.13	2.82	2.03	9.91
Stomach	110.95	111.72	40.63	16.4	9.36	6.95
Intestine	53.49	53.83	20.89	7.60	4.30	22.78
Liver	168.01	168.24	35.40	9.48	2.50	58.87
Pancreas	74.36	74.90	24.21	10.34	6.55	30.78
Urinary	40.73	40.99	13.85	5.79	2.22	16.60
Lymphoma	33.43	33.28	9.62	2.88	0.71	12.49
Other	37.48	37.23	33.72	13.09	6.93	22.66
Total	796.43	746.05	358.15	172.65	108.06	366.25
<u>Female</u>						
Leukemia	59.93	26.35	37.39	25.27	35.27	35.86
Bone	3.10	3.09	3.03	2.84	1.67	2.53
Thyroid	15.85	14.54	11.46	7.46	2.24	8.42
Breast	309.33	310.52	81.01	36.93	10.30	107.63
Lung	78.57	78.89	77.09	64.70	24.96	56.72
Esophagus	21.47	21.57	6.32	3.46	2.26	8.33
Stomach	102.64	103.05	51.49	22.39	10.73	45.00
Intestine	57.14	57.38	23.07	9.57	5.01	23.08
Liver	115.94	115.25	36.97	11.95	2.80	40.74
Pancreas	103.00	103.48	31.71	12.70	7.11	38.15
Urinary	46.40	46.54	19.64	9.08	3.06	18.80
Lymphoma	45.71	45.66	11.54	3.35	0.79	15.13
Other	27.69	27.65	24.48	11.27	5.80	16.20
Total	986.78	955.96	415.21	220.95	112.01	416.59
<u>General</u>						
Leukemia	77.69	34.26	48.06	31.39	41.20	44.76
Bone	3.09	3.06	2.99	2.72	1.58	2.50
Thyroid	12.22	11.33	8.23	5.07	1.61	6.43
Breast	151.21	52.03	39.95	18.40	5.75	55.36
Lung	112.98	113.63	92.34	63.00	23.91	70.07
Esophagus	23.56	23.71	62.22	3.14	2.16	9.09
Stomach	106.89	107.48	45.98	19.37	10.13	45.95
Intestine	55.28	55.57	21.96	8.58	4.70	2.94
Liver	142.55	142.30	36.17	10.71	2.67	49.55
Pancreas	88.36	88.89	27.90	11.51	6.87	34.57
Urinary	43.50	43.71	16.70	7.43	2.69	17.73
Lymphoma	39.44	39.34	10.56	3.11	0.76	13.85
Other	32.69	32.54	29.16	12.18	6.30	19.34
Total	889.49	847.84	386.21	196.60	110.32	392.14

Table C-3. Site-specific incidence risk per unit dose (1.0E-6 per rad) for combined leukemia-bone and constrained relative risk model

Site	Age at Exposure					
	0-9	10-19	20-34	35-50	50	All
Male						
Leukemia	94.68	41.86	58.46	37.52	48.64	54.19
Bone	3.07	3.04	2.96	2.61	1.45	2.47
Thyroid	87.59	82.52	50.84	26.92	8.04	43.23
Breast	0.00	0.00	0.00	0.00	0.00	0.00
Lung	155.21	156.33	114.07	65.31	23.99	89.58
Esophagus	25.57	25.76	6.13	2.82	2.03	9.91
Stomach	147.94	148.97	54.18	21.87	12.48	62.61
Intestine	102.87	103.52	40.16	14.63	8.28	43.81
Liver	168.01	168.24	35.40	9.48	2.50	58.87
Pancreas	81.71	82.31	26.60	11.37	7.20	33.83
Urinary	110.08	110.79	37.44	15.65	6.01	44.87
Lymphoma	45.80	45.58	13.17	3.94	.98	17.12
Other	57.66	57.27	51.88	20.15	10.65	34.86
Total	1080.20	1026.20	491.27	232.28	132.25	495.35
Female						
Leukemia	59.93	26.35	37.39	25.27	35.27	35.86
Bone	3.10	3.09	3.03	2.84	1.67	2.53
Thyroid	158.45	145.42	114.59	74.60	22.38	84.16
Breast	793.16	796.20	207.73	94.69	26.40	275.97
Lung	83.59	83.93	82.01	68.83	26.56	60.34
Esophagus	21.47	21.57	6.32	3.46	2.26	8.33
Stomach	131.59	132.11	66.01	28.69	13.75	57.70
Intestine	103.90	104.34	41.94	17.40	9.11	41.96
Liver	115.94	115.25	36.97	11.95	2.80	40.74
Pancreas	114.44	114.98	35.23	14.11	7.91	42.39
Urinary	100.88	101.16	42.70	19.74	6.66	40.88
Lymphoma	60.95	60.88	15.38	4.47	1.06	20.18
Other	55.38	55.30	48.97	22.54	11.61	32.40
Total	1802.80	1760.60	738.28	388.58	167.42	743.44
General						
Leukemia	77.69	34.26	48.06	31.39	41.20	44.76
Bone	3.09	3.06	2.99	2.72	1.58	2.50
Thyroid	122.24	113.32	82.26	50.66	16.05	64.28
Breast	387.78	389.82	102.42	47.18	14.74	141.95
Lung	120.19	120.88	98.24	67.02	25.43	74.54
Esophagus	23.56	23.71	6.22	3.14	2.16	9.09
Stomach	139.95	140.71	60.00	25.25	13.20	60.08
Intestine	103.38	103.92	41.03	16.00	8.74	42.86
Liver	142.55	142.30	36.17	10.71	2.67	49.55
Pancreas	97.71	98.30	30.85	12.73	7.60	38.23
Urinary	105.58	106.08	40.02	17.68	6.37	42.28
Lymphoma	53.21	53.07	14.26	4.20	1.02	18.69
Other	56.55	56.31	50.43	21.33	11.19	33.60
Total	1433.50	1385.70	612.96	310.01	151.96	622.96

C.3 EXAMPLE CALCULATIONS: EPA RADIONUCLIDE SLOPE FACTORS (1989 - 1992)

C.3.1 General Information

From 1989 to 1991, EPA radionuclide slope factors were derived using the following information:

- Organ-specific dose rates over the lifetime of the exposed population were derived from (1) the RADRISK computer code (Du80) for inhalation and ingestion exposures, assuming constant annual intake of activity; and (2) the DOSFACTER (Ko81) and DFSOIL (Sj84) computer codes for external exposures to radionuclides in soil. (See Appendix A for additional information on the methods and assumptions used to estimate dose rates.)
- Age- and sex-specific cancer incidence risks, assuming equal and constant dose rates in each body organ, were derived from the NAS BEIR III study (NAS80), as summarized in Table C-3. As shown in Table C-3, estimates of the lifetime cancer incidence risks per unit dose for thirteen cancer sites (leukemia, bone sarcoma, thyroid, breast, lung, esophagus, stomach, intestine, liver, pancreas, urinary, lymphoma, and other) and five age intervals (0-9 y, 10-19 y, 20-34 y, 35-49 y, and 50+ y) were considered.
- Vital statistics for the 1970 U.S. population (NCHS73) and the CAIRD computer code (Co78) were used to account for competing risks and estimate the projected years of life remaining at various ages in the reference population. Table C-4 presents the 1970 life table data used for these calculations. The T_x column in Table C-4 displays the expected total collective person-years of life remaining for the survivors of an initial cohort of 100,000 persons, initially liveborn at age zero, who are still alive at a given age, from birth to 110 years. This cohort also represents a stationary population of diverse ages from zero to 110 years, with the mortality statistics of the 1970 U.S. population.

Integration of these data is complicated by the different time periods considered in each. The risk factors are for five age intervals: 0-9 y, 10-19 y, 20-34 y, 35-50 y, and 50+ y. RADRISK computes dose rates for the midpoints of nine time intervals following the beginning of exposure (times 1, 3, 6, 12, 20, 30, 42, 56, and 87 y). The Life Table data are provided for each age in the cohort from 0 to 110 y. These data are integrated by averaging over the age intervals of the risk data, where the data are weighted by the survivors' collective person-years of life remaining at any age, or by the fraction of the time spent by survivors in the smaller age intervals. This averaging process is illustrated in the following section.

C.3.2 Illustrative Examples

The examples presented here are designed to illustrate the principal features of the method for different radionuclides, body organs and endpoints (cancer sites), and pathways of exposure. These examples consider the following radionuclides and exposure pathways: uniform low-LET radiation, exposure to external gamma rays due to Cs-137 in soil, inhalation of Pu-238, and ingestion of Sr-90. The Pu-238 example illustrates how high- and low-LET radiation dose rates and risks are combined to obtain the slope factor.

Because of the large number of calculations involved, the derivation of a slope factor is tedious and computer codes are used to compile and organize the data and calculations that are required. Nevertheless, the purpose here is to present the basic elements of the derivation using a few examples to illustrate the principal considerations.

C.3.2.1 Example A: Risk Estimate for Uniform Low-LET Radiation. Example A considers chronic exposure to low-level low-LET radiation, where it is assumed that each member of the exposed population receives a uniform, constant dose rate of 1 mrad/y (10^{-5} Gy/y) to all body organs. For purposes of this and the following

examples, the cohort survivors' life expectancy data from Table C-4 have been aggregated over the age intervals for the risk model as shown in Table C-1 (i.e., 0-9 y, 10-19 y, 20-34 y, 35-49 y, and 50+ y). These five intervals are denoted as "Risk Intervals" to distinguish them from other age intervals used in the calculations. [Note that somewhat different risk intervals are used under EPA's revised methodology, as discussed in the main text.]

The data in the columns labelled T_x in Table C-4 express the collective expected person-years of life remaining in the survivors of an initial cohort of 100,000 persons, initially liveborn at age zero, who are still alive at a given age. For example, at age 0, the 100,000 persons in the cohort have a collective remaining life expectancy of 7,075,647 person-y. (A person aged 0 is living in his/her first year.) From this information, the collective person-y lived by the survivors within each Risk Interval can be computed from a successive subtraction of adjacent life expectancies. These results, which will be used in the following analyses, are summarized below.

Risk Interval (y)	Person-y Lived by Cohort Survivors in Risk Interval
0-9	9.780E+5
10-19	9.719E+5
20-34	14.346E+5
35-49	13.841E+5
50+	23.070E+5

It should be noted that, when normalized by the length of the respective risk interval, the person-y lived by the cohort survivors decreases monotonically. This accounts for the fact that some deaths are expected to occur from causes other than radiation exposure at each age. This consideration becomes more important at later ages, since the baseline mortality rates generally increase with age. Accounting in this way assures that the radiation-induced excess cancer incidence risk is calculated for only the surviving population at any age.

Table C-4 indicates the initial collective person-y of life expected for the cohort to be 70.756×10^5 person-y. Dividing by the initial size of the cohort, i.e., 100,000, provides the average (expected) lifetime of an individual in the cohort. Thus, individuals born in the reference population are expected to live an average of 70.756 years.

The cohort life expectancy data in Table C-4 may be used in conjunction with the age-specific attributable cancer incidence risk per unit dose from Table C-3, to estimate the total lifetime attributable cancer incidence risk resulting from uniform low-LET irradiation, assuming chronic equal dose rates to each body organ, as illustrated in Table C-5.

**Table C-4. Reference life table data used for EPA risk estimates prior to 1994
(1970 decennial life table for U.S. population - male and female combined)**

Age	q_x	l_x	T_x	Age	q_x	l_x	T_x
0	0.0200200000	100000.0000000000	7075647.4998189092	56	0.0123481730	84141.9999290323	1786559.5004443347
1	0.0012449230	97998.0000000000	6976648.4998189092	57	0.0134170850	83102.9999573426	1702937.0005011472
2	0.0008582290	97876.0000358460	6878711.4998009864	58	0.0145143190	81987.9999431600	1620391.5005508962
3	0.0006953530	97792.0000142112	6780877.4997759578	59	0.0157058340	80797.9999578130	1538998.5006004099
4	0.0005730420	97724.0000536253	6683119.4997420397	60	0.0169497920	79528.9999829435	1458835.0006300318
5	0.0005017000	97668.0000971866	6585423.4996666338	61	0.0182908890	78180.9999752646	1379980.0006509279
6	0.0004712200	97619.0000615378	6487779.9995872716	62	0.0197391560	76750.9999828080	1302514.0006718917
7	0.0004304470	97573.0000363288	6390183.9995383383	63	0.0213328730	75236.0000209914	1226520.5006699921
8	0.0003793670	97531.0000311822	6292631.9995045830	64	0.0230609390	73630.9999875156	1152087.0006657387
9	0.0003487390	97493.9999882933	6195119.4994948453	65	0.0249398750	71932.9999882945	1079305.0006778338
10	0.0003078190	97460.0000282314	6097642.4994865831	66	0.0269892640	70138.9999602114	1008269.0007035810
11	0.0002976500	97429.9999884827	6000197.4994782261	67	0.0291885240	68245.9999735893	939076.5007366807
12	0.0003490720	97400.9999489862	5902781.9995094917	68	0.0315150780	66253.9999654562	871826.5007671580
13	0.0004621690	97366.9999871319	5805397.9995414328	69	0.0340055480	64165.9999887328	806616.5007900635
14	0.0006267850	97321.9999781149	5708053.4995588094	70	0.0366062210	61983.9999961480	743541.5007976232
15	0.0008225290	97261.0000083586	5610761.9995655727	71	0.0394373270	59714.9999938250	682692.0008026367
16	0.0010084280	97181.0000152827	5513540.9995537521	72	0.0426603900	57360.0000122635	624154.5007995925
17	0.0011639520	97082.9999737993	5416408.9995592113	73	0.0464370910	54913.0000413403	568018.0007727906
18	0.0012787460	96970.0000218138	5319382.4995614048	74	0.0507610340	52363.0000613376	514380.0007214517
19	0.0013423370	96846.0000221659	5222474.4995394151	75	0.0555074940	49705.0000348820	463346.0006733418
20	0.0014061790	96716.0000530341	5125693.4995018153	76	0.0606015420	46946.0000436758	415020.5006340629
21	0.0014702840	96580.0000447955	5029045.4994529006	77	0.0659622230	44101.0000502970	369497.0005870765
22	0.0015139260	96438.0000160097	4932536.4994224980	78	0.0715430180	41192.0000504563	326850.5005366999
23	0.0015266070	96292.0000203974	4836171.4994042946	79	0.0773957380	38245.0000493905	287132.0004867765
24	0.0015081390	96144.9999791223	4739952.9994045349	80	0.0839450190	35285.0000457579	250371.0004392023
25	0.0014687500	95999.9999549988	4643880.4994374744	81	0.0912044050	32323.0000465017	216563.0003930725
26	0.0014396140	95858.9999550648	4547950.9994824426	82	0.0989276600	29375.0000594456	185714.0003400988
27	0.0014103490	95720.9999967035	4452160.9995065585	83	0.1069553060	26469.0000410648	157792.0002898437
28	0.0014437260	95585.9999800792	4356507.4995181672	84	0.1154920040	23638.0000421587	132738.5002482320
29	0.0014772440	95447.9999866719	4260990.4995347918	85	0.1255978570	20908.0000467377	110465.5002037838
30	0.0015633690	95307.0000013796	4165612.9995407662	86	0.1374576090	18282.0000467115	90870.5001570592
31	0.0016288700	95157.9999920945	4070380.4995440294	87	0.1497875580	15769.0000325527	73845.0001174271
32	0.0017157350	95002.9999806473	3975299.9995576586	88	0.1616319830	13407.0000255747	59257.0000883634
33	0.0018346690	94840.0000084755	3880378.4995630973	89	0.1728647690	11240.0000253600	46933.5000628961
34	0.0019436760	94666.0000005000	3785625.4995586097	90	0.1850059160	9297.0000174161	36665.0000415080
35	0.0020850530	94481.9999682830	3691051.4995742184	91	0.1988913820	7577.0000131421	28228.0000262289
36	0.0022485020	94284.9999908031	3596667.9995946754	92	0.2136738060	6070.0000091142	21404.5000151008
37	0.0024449100	94072.9999797538	3502488.9996093970	93	0.2285774150	4773.0000047467	15983.0000081703
38	0.0026640240	93842.9999613733	3408530.9996388336	94	0.2433460080	3682.0000018667	11755.5000048635
39	0.0028955160	93592.9999572442	3314812.9996795249	95	0.2577171570	2785.9999999565	8521.5000039519
40	0.0031503820	93321.9999283800	3221355.4997367130	96	0.2693423600	2068.0000005657	6094.5000036908
41	0.0033968270	93027.9999796016	3128180.4997827224	97	0.2806088680	1510.9999999333	4305.0000034413
42	0.0037104150	92711.9999575149	3035310.4998141644	98	0.2897884080	1087.0000004040	3006.0000032726
43	0.0040381950	92367.9999621925	2942770.4998543109	99	0.2979274610	772.0000007910	2076.5000026751
44	0.0044350240	91994.9999665852	2850588.9998899221	100	0.3081180810	542.0000006633	1419.5000019480
45	0.0048369310	91586.9999338533	2758797.9999397029	101	0.3146666670	375.0000005569	961.0000013379
46	0.0052883350	91143.9999346763	2667432.5000054382	102	0.3190661480	257.0000002567	645.0000009311
47	0.0057355890	90661.9999297817	2576529.5000732094	103	0.3314285710	175.0000001388	429.0000007334
48	0.0062457010	90141.9999602665	2486127.5001281854	104	0.3333333330	117.0000001678	283.0000005801
49	0.0067761420	89578.9999809726	2396267.0001575660	105	0.3333333330	78.0000001509	185.5000004208
50	0.0073843460	88971.9999568835	2306991.5001886380	106	0.3461538460	52.0000001266	120.5000002820
51	0.0080394040	88314.9999248899	2218348.0002477514	107	0.3529411760	34.0000000908	77.5000001734
52	0.0087552080	87604.9999612337	2130388.0003046896	108	0.3636363640	22.0000000747	49.5000000906
53	0.0095695430	86837.9999647331	2043166.5003417062	109	0.3571428570	14.0000000396	31.5000000335
54	0.0104293840	86006.9999900366	1956744.0003643215	110	0.0000000000	0.0000000000	20.0000000000
55	0.0113735170	85109.9999604525	1871185.5003890770				

tx=reference probability of death at age x. lx=number of members of initial cohort surviving to age x. Tx=years of life remaining to the survivors at age x

**Table C-5. Attributable Cancer Risk from Uniform Low-LET Radiation
(chronic constant dose rate to all organs)**

Risk Interval (y)	Dose Rate (rad/y)	Survivor Exposure Duration (person-y)	Interval Risk Factor (rad ⁻¹)	Attributable Cancers
0-9	0.001	9.780E+5	1443.5E-6	1.41
10-19	0.001	9.719E+5	1385.7E-6	1.35
20-34	0.001	14.346E+5	612.9E-6	0.88
35-49	0.001	13.841E+5	310.0E-6	0.43
50+	0.001	<u>23.070E+5</u>	151.9E-6	<u>0.35</u>
Average individual risk = 4.42 attributable cancers/(70.756E+5 p-y x 0.001 rad/y) = 6.2E-4 attributable cancers/rad				

Within each risk interval, risk is computed as the product of the pertinent dose rate, expected duration of exposure of the cohort survivors, and lifetime risk factor at the age being considered. The cancers projected for each risk interval are summed to estimate the total number of attributable cancers projected in the lifetime of the survivors of the cohort (4.42 cancers).

Hence, a chronic dose rate of 1 mrad/y (10^{-5} Gy) in each body organ results in an expected lifetime sum-total collective dose of $0.001 \text{ rad/y} \times 70.756\text{E}+5 \text{ person-y} = 7075.6 \text{ person-rad}$ ($7.0756\text{E}+5 \text{ person-Gy}$) in each organ for members of the cohort. This collective dose is expected to induce a total of 4.42 attributable cancers during the lifetime of the initial population of 100,000 persons. Thus, the average individual's risk at age zero due to the radiation exposure is estimated to be $4.42/100,000 = 4.42\text{E}-5$ attributable cancers per person under the assumed exposure conditions (chronic dose rate of 1 mrad/y in all body organs). For comparison, the current baseline cancer incidence risk from all causes is about 0.3.

The estimated lifetime cancer incidence risk per unit lifetime dose is the expected number of attributable cancers in the cohort survivors divided by the projected total lifetime collective dose, or $4.42 \text{ attributable cancers}/7075.6 \text{ person-rad} = 6.2\text{E}-4 \text{ per person-rad}$ ($6.2\text{E}-6 \text{ Gy}^{-1}$).

This illustration is simplistic in that it assumes identical dose rates in all body organs at all times. In many exposure situations, this is not the case, especially for internal exposures. In these cases, the dose rates at various ages must be appropriately averaged in the discrete risk intervals, as illustrated in the following examples.

C.3.2.2 Example B: External Exposure to Cs-137+D in Soil. Example B considers the case of chronic exposure to gamma radiation from Cs-137 in soil contaminated at a uniform level of 1 pCi of Cs-137 per gram of soil (1 pCi/g or 0.037 Bq/g). Cs-137 is a pure beta-emitter, which decays to Ba-137m with a half-life of approximately 30 years and a branching fraction of 0.946—i.e., 94.6% of all Cs-137 atoms decay to produce Ba-137m. For this example, Cs-137 is assumed to be in equilibrium with its radioactive decay product Ba-137m, i.e., the soil is also assumed to contain a uniform concentration of 0.946 pCi/g of Ba-137m per gram

of soil (0.740 pCi/g or 0.037 Bq/g). This is a case where inclusion of the radioactive decay products is extremely important in estimating radiation risk, since the external pathway dose from this decay series is entirely from Ba-137m. The inclusion of radioactive decay products in radionuclide slope factors is indicated as "Cs-137+D".

Although Cs-137 decays with a half-life of 30 years, the slope factor derivation assumes exposure to a constant and uniform soil contamination level, and constant dose rates in the various body organs. The decrease in radionuclide concentrations over time (i.e., by radioactive decay and also any physical removal processes) should be accounted for in pathway modeling used in conjunction with the slope factors to estimate risk. Conceptually, this can be accommodated by calculating the exposure-time integral in the appropriate units (e.g., pCi-y/g) and multiplying by the slope factor to obtain the lifetime risk.

In this example, however, it is assumed that the ground contamination level is constant and uniform. Thus, the dose rates in each body organ will also be constant over the lifetime of the exposed population. However, since some body organs are shielded by other body organs, each organ can be subjected to a slightly different, but constant, dose rate. Since the dose rates in this example are constant over the life of the cohort, averaging dose rates over the five risk intervals is unnecessary. Table C-6 shows the necessary data and calculations for estimating attributable cancer risk for this example. The first column lists the risk intervals. The second lists the organ dose rate for each risk interval.

Table C-6. Derivation of Attributable Cancer Risk Resulting from Chronic Exposure to Gamma Radiation from Cs-137+D Ground Contamination (1 pCi/g, 0.037 Bq/g)

Risk Interval (y)	Dose Rate (rad/y)	Effective Duration (p-y)	Interval Risk Factor (rad ⁻¹)	Attributable Cancers
Breast				
0-9	3.54E-3	9.780E+5	387.78E-6	1.34
10-19	3.54E-3	9.719E+5	389.82E-6	1.34
20-34	3.54E-3	14.346E+5	102.42E-6	0.52
35-49	3.54E-3	13.841E+5	47.18E-6	0.23
50+	3.54E-3	<u>23.070E+5</u>	14.74E-6	<u>0.12</u>
		70.756E+5		3.56
Lung				
0-9	2.92E-3	9.780E+5	120.19E-6	0.34
10-19	2.92E-3	9.719E+5	120.88E-6	0.34
20-34	2.92E-3	14.346E+5	98.24E-6	0.41
35-49	2.92E-3	13.841E+5	67.02E-6	0.27
50+	2.92E-3	<u>23.070E+5</u>	25.44E-6	<u>0.17</u>
		70.756E+5		1.54
[etc. for each of the 13 cancer sites]				
Lifetime attributable cancers in cohort = 14.15				
Slope Factor = 14.15 attributable cancers / (70.756E+5 person-y x 1 pCi/g) = 2E-6 attributable cancers per pCi-y/g				

The third column lists the collective years of life lived by survivors in each risk interval. The fourth column lists the pertinent risk factors from Table C-3. The last column is the predicted attributable cancers in each age interval, calculated as the product of the pertinent dose rate, collective exposure duration, and risk factor. This calculation is repeated for each risk interval and for each of the 13 cancer sites considered.

The slope factor is then computed as the projected number of attributable cancers in the cohort divided by the total exposure of the cohort. At the assumed constant soil contamination level of 1 pCi/g (0.037 Bq/g), the expected number of attributable cancers in the cohort survivors is approximately 14 cancers. The collective exposure duration of the cohort is 70.756E+5 person-years. Thus, the slope factor may be calculated as

$$\begin{aligned} \text{SF} &= 14 \text{ attributable cancers} / (70.756\text{E}+5 \text{ person-y} \times 1 \text{ pCi/g}) \\ &= 2.0\text{E}-6 \text{ attributable cancers per pCi-y/g.} \end{aligned}$$

C.3.2.3 Example C: Inhalation of Pu-238. Example C considers the case of chronic inhalation of Pu-238 at a constant rate of 1 pCi/y (0.037 Bq/y). In the calculation of ingestion and inhalation slope factors, it is assumed that survivors in the cohort chronically ingest or inhale a constant amount of activity of a given radionuclide each year (e.g., 1 pCi/y) throughout each survivor's lifetime. Unlike the cases considered above, where the dose rates in body organs remained constant over time, in this example dose rates in body organs are not constant as survivors age, and average dose rates in each risk interval must be calculated.

For this example, it is assumed that the chemical form of the particles carrying the Pu-238 is insoluble in body fluids, i.e., the clearance time of the particles from the lung is very long (i.e., ICRP lung clearance class "Y"; see Appendix A). In this case, the dose rate to body organs increases rapidly during the first few years of exposure, and then plateaus asymptotically. For the purpose of this calculation, this means that dose rates will vary significantly over the risk interval 0-9 y, and then become relatively constant for subsequent intervals. Thus, an average dose rate for the 0-9 y interval must be calculated, taking into account the cohort survival. This is done by calculating the fraction of the time spent by survivors in the age groups within this risk interval. For the 0-9 y risk interval, three age groups are considered: 0-2, 2-4, and 4-10. Dose rates in the middle of these age intervals, at 1, 3 and 6 y of age, are used to estimate the average dose rate in the 0-9 y interval. Similarly, a weighted average of the dose rate to each organ of interest is computed for each of the five risk intervals.

Since Pu-238 is an alpha-emitter and weak photon emitter, both high- and low-LET dose rates must be considered. The high-LET dose rates are adjusted for the greater relative biological effectiveness (RBE) of the alpha particles in inducing lung cancer, relative to beta and gamma radiation. Prior to 1992, EPA's risk estimates assumed an RBE of eight for estimating risks from alpha particles for all cancer sites. [In the development of radionuclide slope factors published in 1992, the high-LET RBE for leukemia was reduced from 8 to 1.117. EPA's revised methodology has adopted an RBE value of 20 for all cancer sites except leukemia, for which an RBE of 1 is assigned and breast which is assigned an RBE of 10.]

The weighted average dose rates for each organ of interest are combined with the corresponding life table data from Table C-4 and the age-specific radiogenic cancer risk values from Table C-3 to estimate the number of radiation-induced excess cancers in the survivors in each risk interval, as illustrated in Table C-7. Under the assumed exposure conditions, the expected number of attributable cancers in the cohort survivors is approximately 0.3 cancers. Since this attributable cancer risk arises in an initial cohort of 100,000 persons, the lifetime risk to an average individual initially in the cohort is 0.3/100,000, or 3.0E-6, or three chances in

**Table C-7. Derivation of Attributable Cancer Risk Resultin
from Chronic Inhalation of Pu-238 [1 pCi/y (0.037 Bq/y) constant intake rate]**

Risk Interval (y)	Dose Rate (rad/y)	Effective Duration (p-y)	Interval Risk Factor (rad ⁻¹)	Attributable Cancers
LUNG				
High-LET Contribution				
0-9	4.31E-5	9.780E+5	8 x 120.19E-6	4.05E-2
10-19	5.32E-5	9.719E+5	8 x 120.88E-6	5.00E-2
20-34	5.33E-5	14.346E+5	8 x 98.24E-6	6.01E-2
35-49	5.34E-5	13.841E+5	8 x 67.02E-6	3.96E-2
50+	5.35E-5	<u>23.070E+5</u> 70.756E+5	8 x 25.44E-6	<u>2.51E-2</u> 2.15E-1
Low-LET Contribution				
0-9	9.07E-8	9.780E+5	120.19E-6	1.07E-5
10-19	1.12E-7	9.719E+5	120.88E-6	1.32E-5
20-34	1.12E-7	14.346E+5	98.24E-6	1.58E-5
35-49	1.12E-7	13.841E+5	67.02E-6	1.04E-5
50+	1.12E-7	<u>23.070E+5</u> 70.756E+5	25.44E-6	<u>6.57E-6</u> 5.67E-5
[etc. for each of the 13 cancer sites]				
Lifetime attributable cancers in cohort = 0.3				
Slope Factor = 0.3 attributable cancers / (70.756E+5 person-y x 1 pCi/y) = 3.9E-8 attributable cancers/pCi inhaled				

a million, in this example. This attributable cancer risk may be divided by the total exposure (intake) of the cohort to estimate the radionuclide slope factor for inhalation of Pu-238 (Class Y) as follows:

$$\begin{aligned}
 SF &= 0.3 \text{ attributable cancers} / (70.756E+5 \text{ person-y} \times 1 \text{ pCi/y}) \\
 &= 3.9E-8 \text{ attributable cancers/pCi inhaled}
 \end{aligned}$$

C.3.2.4 Example D: Ingestion of Sr-90. Example D considers the case of chronic ingestion of Sr-90 at a constant rate of 1 pCi/y over a lifetime. It is assumed here that the chemical form of the Sr-90 is soluble in the gastrointestinal tract, with a GI-tract-to-blood absorption fraction (f_1) of 0.3. Since strontium accumulates preferentially in the skeletal tissues, the dose rates to these tissues exceed those for other body organs; therefore, this example focuses on attributable risk of bone sarcoma and leukemia (red bone marrow). The annual dose rates computed by RADRISK for these tissues increase with time, due to the accumulation of Sr-90 in these tissues—i.e., the deposition and retention of Sr-90 in bone surfaces and red bone marrow greatly exceeds its biological and radiological removal rate.

Since the dose rates to bone surface and red marrow are not constant, average dose rates in each of the five risk intervals are calculated. For each cancer site, the dose rate within each risk interval is calculated as a weighted average based on the fraction of time spent by survivors in each age group within this risk interval.

Attributable cancer risk for this case is calculated as shown in Table C-8. In each risk interval, the average dose rates are multiplied by the person-years of life expected for survivors in the time intervals over which

Table C-8. Derivation of Attributable Cancer Risk Resulting from Chronic Ingestion of Sr-90 (1 pCi/y constant intake rate)

Risk Interval (y)	Dose Rate (rad/y)	Effective Duration (p-y)	Interval Risk Factor (rad ⁻¹)	Attributable Cancers
Leukemia				
0-9	2.96E-7	9.78E+5	77.69E-6	2.25E-5
10-19	5.60E-7	9.719E+5	34.26E-6	1.86E-5
20-34	6.28E-7	14.346E+5	48.06E-6	4.33E-5
35-49	6.49E-7	13.841E+5	31.39E-6	2.82E-5
50+	6.51E-7	<u>23.070E+5</u> 70.756E+5	41.20E-6	<u>6.19E-5</u> 1.75E-4
Bone Sarcoma				
0-9	4.89E-7	9.78E+5	3.09E-6	1.48E-6
10-19	1.04E-6	9.719E+5	3.06E-6	3.09E-6
20-34	1.27E-6	14.346E+5	2.99E-6	5.44E-6
35-49	1.42E-6	13.841E+5	2.72E-6	5.35E-6
50+	1.47E-6	<u>23.070E+5</u> 70.756E+5	1.58E-6	<u>5.36E-6</u> 2.07E-5
[etc. for each of the 13 cancer sites]				
Lifetime attributable cancers in cohort = 2.3E-4				
Slope Factor = 2.3E-4 attributable cancers/(70.756E+5 person-y x 1 pCi/y) = 3.3E-11 attributable cancer/pCi ingested				

the dose rate factors apply, to obtain the collective dose in the interval. These doses are multiplied by the attributable cancer incidence risk per unit dose, obtained from Table C-3, to estimate the committed risk for the interval. The sum of these products is divided by the total lifetime intake of the cohort, 70.756E+5 pCi, to obtain the slope factor. Under the assumed exposure conditions, the expected number of attributable cancers in the cohort survivors is approximately 2E-4 cancers; this represents an individual risk of approximately 2E-4/1E+5, or 2E-9, or two chances in a billion, in this example. This attributable cancer risk may be divided by the total exposure (intake) of the cohort to estimate the radionuclide slope factor for ingestion of Sr-90 as

$$\begin{aligned} \text{SF} &= 2.3\text{E-}4 \text{ attributable cancers} / (70.756\text{E+}5 \text{ person-y} \times 1 \text{ pCi/y}) \\ &= 3.3\text{E-}11 \text{ pCi}^{-1} \text{ ingested.} \end{aligned}$$

Note that this example considers ingestion of Sr-90 only. In the modified case where Sr-90 is assumed to be in equilibrium with its radioactive daughter, Y-90, estimates of dose and risk are approximately 10% higher. While RADRISK explicitly accounts for ingrowth of radioactive decay products following intake, it does not address intake of multiple radionuclides.

C.4 INTERIM 1992 REVISIONS IN DOSE AND RISK MODELS

In 1992, radiological slope factors for inhalation and ingestion were revised consistent with recommendations of the EPA Science Advisory Board (SAB) for the regulation of radionuclides in drinking water. These changes included a reduction in the GI absorption factor (f_1) for uranium radionuclides from 0.2 to 0.05, incorporation of sinus carcinomas in the Ra-226 risk, an adjustment in the doses and resultant risks of bone cancer and leukemia risks for Ra-228, a reduction in the leukemia risk from alpha radiation, and a recalculation of the urinary system cancer risk based on the dose to both the kidney and the urinary bladder.

The changes to the radium risk estimates reflect three distinct corrections. First, the Agency's high-LET risk calculated for leukemia was found to be high when compared to epidemiological studies of leukemia incidence among radium dial painters exposed to Ra-226 and Ra-228, patients injected with Ra-224, and Thorotrast patients. The epidemiological data for leukemia from the high-LET absorbed dose from alpha particles indicate an average risk of approximately $5 \times 10^{-5} \text{ rad}^{-1}$, which is only 11.7% higher than the value for low-LET risk. In order to correct this discrepancy, the high-LET leukemia risks calculated by RADRISK for all radionuclides have been multiplied by a factor of 0.1396 to bring them in line with the bone marrow dyscrasia observed in Ra-224, Ra-226 and Thorotrast patients. This corresponds to a reduction in the alpha particle quality factor from 8 to 1.117 for leukemia.

Second, the SAB pointed out that neither the RADRISK model nor the ICRP publication 30 model from which it was derived includes a calculation of the paranasal sinus and mastoid carcinomas that apparently result from trapped Rn-222 gas produced by the decay of Ra-226. A contribution from these cancers was included by assuming that their risk is equal to that of bone sarcoma and then adding this value to the total risk for an intake of Ra-226.

Third, it was discovered that, contrary to ICRP and NRPB dosimetric estimates showing that Ra-228 may yield a dose to bone 1.5 to 2.8 times higher than Ra-226, RADRISK calculates a lower risk of bone sarcoma from Ra-228 than from Ra-226. This discrepancy was due to the choice of assumptions regarding the biokinetic model for radioactive decay products—i.e., the RADRISK calculations assumed that each radioactive decay product would be distributed and retained in body tissues according to the characteristics of that element, whereas ICRP estimates assumed that all progeny would follow the biokinetic model of the parent radionuclide. A multiplicative correction factor was used to make the relationship of these doses consistent with those calculated for Ra-226 and Ra-228 by the ICRP publication 30 model and the NRPB model from which both were derived.

The effect of the above changes was to lower the Ra-226 total mortality risk by 7% and increase the mortality risk for Ra-228 by 0.3%, as indicated in Table C-9.

**Table C-9. Cancer Mortality Risk (Original and Revised Values)
from Lifetime Ingestion of ²²⁶Ra or ²²⁸Ra in Drinking Water**

	Risk (Deaths/μCi)	
	²²⁶ Ra	²²⁸ Ra
Previous RADRISK values:		
Bone sarcoma	1.85E-5	8.53E-6
Leukemia	3.10E-5	1.69E-5
All other	4.40E-5	4.48E-5
Total	9.35E-5	7.02E-5
Revised values:		
Bone sarcoma	1.85E-5	1.90E-5
Sinus carcinoma	1.85E-5	-
Leukemia	5.94E-6	1.01E-5
All other	4.39E-5	4.48E-5
Total	8.68E-5	7.39E-5

Previously, the urinary system cancer risk was calculated on the basis of the dose to the kidney, even when the dose calculated for the bladder was much lower. As a result, urinary cancer risks were appreciably over-estimated for certain radionuclides, particularly uranium. To correct this problem, the risk estimates were adjusted as follows:

$$\begin{aligned} \text{adjusted mortality risk/original mortality risk} &= (1+C)/2, \\ \text{adjusted incidence risk/original incidence risk} &= (1+2C)/3, \end{aligned}$$

where C is the ratio of the bladder dose rate to the kidney dose rate. The corrections presumed: 1) approximately equal excess relative risk per unit dose for kidney and bladder; 2) roughly equal baseline cancer mortality rates for the two sites; and 3) an incidence rate for the bladder that is twice that for the kidney. In the revised methodology, cancer risks to bladder and kidneys are calculated separately, so this adjustment is not needed.

The adjusted leukemia, urinary and total risks for some selected uranium nuclides are listed in Table C-10. For the uranium isotopes, the revised ingestion risks were reduced by a factor of 7 due to a lowering of the GI absorption factor, f_1 , from 0.2 to 0.05, and a reduction in leukemia and urinary cancer risk estimates. The effect of these revisions on corresponding risk estimates for inhalation exposures are much smaller.

**Table C-10. Cancer Mortality Risk (Previous and Revised Values)
from Lifetime Ingestion of Uranium**

	Risk (Deaths/ μ Ci)				
	^{232}U	^{233}U	^{234}U	^{235}U	^{238}U
Previous RADRISK values ($f_1 = 0.2$):					
Leukemia	4.27E-5	1.42E-5	1.42E-5	1.52E-5	1.93E-5
Urinary	9.97E-5	4.34E-5	4.36E-5	4.00E-5	3.90E-5
Total	1.90E-4	7.55E-5	7.48E-5	7.32E-5	7.40E-5
Revised values ($f_1 = 0.05$)					
Leukemia	1.64E-6	5.02E-7	5.24E-7	9.98E-7	2.30E-6
Urinary	1.25E-5	5.48E-6	5.41E-6	5.03E-6	4.91E-6
Total	2.70E-5	1.12E-5	1.11E-5	1.15E-5	1.19E-5

C.5 REFERENCES

- Bu81 Bunger, B., Cook, J.R. and M.K. Barrick, "Life Table Methodology for Evaluating Radiation Risk: An Application Based on Occupational Exposure", Health Phys. **40** (4):439-455, 1981.
- Co78 J.R. Cook, B.M. Bunger, and M.K. Barrick, A Computer Code for Cohort Analysis of Increased Risks of Death (CAIRD), EPA 520/4-78-012, U.S. EPA, June 1978.
- Du80 Dunning, D.E. Jr., R.W. Leggett, and M.G. Yalcintas, A Combined Methodology for Estimating Dose Rates and Health Effects from Exposure to Radioactive Pollutants, ORNL/TM-7105, Oak Ridge National Laboratory, Oak Ridge, TN, 1980.
- EPA84 Environmental Protection Agency, Radionuclides: Background Information Document for Final Rules. Volume I, EPA Report 520/1-84-022-1, US EPA, Office of Radiation Programs.
- EPA89 Environmental Protection Agency, Risk Assessment Guidance for Superfund Volume 1 Human Health Evaluation Manual (Part A), Interim Final, EPA/540/1-89/002, USEPA, Washington, 1989.
- EPA94 Environmental Protection Agency, Estimating Radiogenic Cancer Risks, J.S. Puskin and C.B. Nelson, Office of Radiation and Indoor Air, EPA 402-R-93-076, June 1994.
- Ko81 Kocher, D.C., Dose Rate Conversion Factors for External Exposure to Photons and Electrons, NUREG/CR-1918, ORNL/NUREG-79, Oak Ridge National Laboratory, Oak Ridge, TN, 1981.
- NAS80 National Academy of Sciences - National Research Council, The Effects on Populations of Exposure to Low Levels of Ionizing Radiation, Committee on the Biological Effects of Ionizing Radiation, (BEIR III), Washington, D.C., 1980.
- NCHS73 National Center for Health Statistics, Public Use Tape, Vital Statistics - Mortality Cause of Death Summary - 1970, PB80-133333, Washington, D.C., 1973.
- NCHS75 National Center for Health Statistics, U.S. Decennial Life Tables for 1969-71, 1(1), DHEW Publication No. (HRA) 75-1150, U.S. Public Health Service, Rockville, Maryland, 1975.

- NCRP85 National Council on Radiation Protection and Measurements, Induction of Thyroid Cancer by Ionizing Radiation, NCRP Report No. 80, Washington, D.C., 1985.
- NRC85 Nuclear Regulatory Commission, Health Effects Model for Nuclear Power Plant Accident Consequence Analysis. NUREG/CR-4214. U.S. Nuclear Regulatory Commission, Washington, DC, 1985.
- Sj84 Sjoreen, A.L., D.C. Kocher, G.G. Killough, and C.W. Miller, MLSOIL and DFSOIL - Computer Codes to Estimate Effective Ground Surface Concentrations for Dose Computations, ORNL-5974, Oak Ridge National Laboratory, Oak Ridge, TN, 1984.

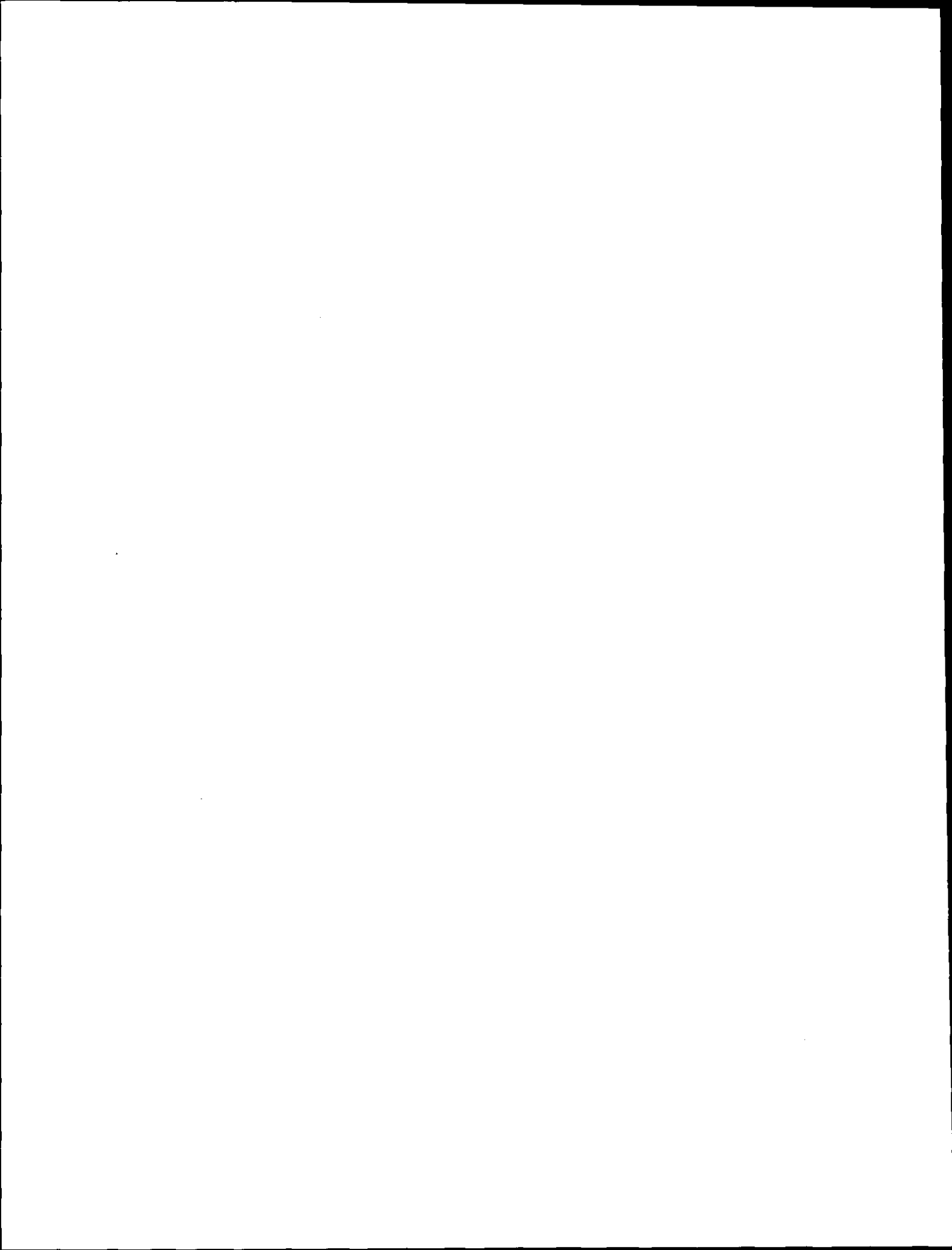

Appendix D

Calculational Methods for Radiogenic Cancer Risk Estimates

[This page is blank intentionally.]

CONTENT

Section	Page
D.1 INTRODUCTION	D-5
D.2 RISK MODEL FORMULATION	D-6
D.3 RISK MODELS	D-7
D.3.1 Risk model coefficients	D-7
D.3.2 Time since exposure response function	D-7
D.3.3 Age at expression function	D-8
D.4 RISK CALCULATIONS	D-8
D.4.1 Basic quantities	D-8
D.4.2 Attributable lifetime risk coefficient	D-10
D.4.3 Attributable lifetime loss coefficient	D-10
D.4.4 Age-averaged coefficients	D-11
D.4.5 Sex-averaged coefficients	D-11
D.4.6 Continuity considerations	D-13
D.4.7 Cancer type and dose location associations	D-13
D.4.8 Cancer incidence calculations	D-15
D.5 BASELINE FORCE OF MORTALITY CALCULATIONS	D-15
D.6 RADIONUCLIDE RISK COEFFICIENTS	D-16
D.6.1 Radiogenic Risk from Internal Exposure	D-16
D.6.2 Radiogenic Risk from External Exposure	D-18
D.7 RADIONUCLIDE SLOPE FACTOR CALCULATION	D-18
D.8 REFERENCES	D-19

TABLES

Table		Page
D-1	Target organs and tissues used by EPA for calculation of cancer risk	D-14

Appendix D

Calculational Methods for Radiogenic Cancer Risk Estimates¹

D.1 INTRODUCTION

A radiogenic cancer risk model defines the relationship between radiation dose and the subsequent force of mortality (or morbidity) attributable to that dose. As such, the model provides the basis for calculating a time (or age) varying rate coefficient in a death or disease process model. [General methods for structuring and solving the differential equations representing such stochastic processes can be found elsewhere (Ch80).] Thus, to calculate risks, the radiogenic risk model and other relevant quantities must be incorporated into a suitable calculational procedure.

The risk calculations discussed in this section are for attributable risk. In this context, attributable risk is defined as the likelihood of death from (or development of) cancer that, according to the risk model, is caused by a radiation exposure. By way of comparison, the excess risk calculated in BEIR V (NAS90, Va89) excludes the fraction of the attributable risk that represents deaths or cases among persons who would be expected to die from (or to develop) cancer at a later age even if they had not been exposed.

The use of the attributable risk-per-unit-dose coefficients calculated here is limited to the asymptotic case, i.e., these coefficients can only be used for applications where the survival function is not significantly affected by the doses being assessed. When this is not the case, risks must be calculated explicitly for the specific doses under consideration.

Male and female survival data used in these calculations (up to an age of 110 y) are taken from the *U.S. Decennial Life Tables for 1979-1981* (NCHS85). These data were used to calculate a combined life table for a male:female live birth ratio of 1.051. U.S. mortality data were extracted from 1979-1981 Vital Statistics Mortality Data, Detail Tapes (NCHS82, 83, 84). Deaths in these data files are classified according to the 9th edition of the International Classification of Disease (ICD) codes (PHS80).

Radiogenic risk calculations require integrating functions of the risk model and vital statistics. The vital statistics are discrete data, typically tabulated at one or five year intervals. Radiogenic risk models are usually defined for several different age intervals and are inherently discontinuous. Previously, such risk model calculations were implemented by adapting actuarial methods developed for life table calculations, e.g., the CAIRD program (Co78) which is incorporated into the RADRISK code (Du80). The method used here is to fit a cubic spline to discrete data and then to calculate interpolated values, derivatives, and integrals directly

¹ The mathematical presentation in this section is adapted from *Estimating Radiogenic Cancer Risks* (EPA94), and is reproduced here for the convenience of the reader.

from the spline coefficients (de78, Fr82). This method admits almost any form of risk model and eliminates most of the ad hoc approaches that were necessary with CAIRD. This revised calculational approach is implemented in the CRDARTAB computer code (Sj94).

D.2 RISK MODEL FORMULATION

As noted in Section 2.2.3, there are two basic types of radiogenic cancer risk projection models: absolute risk and relative risk. An absolute risk model presumes that the age-specific excess force of mortality (or morbidity) due to a radiation dose is independent of cancer mortality or incidence rates in the population. It can be written as

$$\epsilon(x, x_e) = \alpha(x_e) \zeta(t, x_e) \gamma(x) \quad (D-1)$$

where

- $\epsilon(x, x_e)$ = the excess force of mortality (or morbidity) ($y^{-1} Gy^{-1}$) at age x due to a dose at age x_e ($x > x_e$),
- $\alpha(x_e)$ = the absolute risk coefficient ($y^{-1} Gy^{-1}$), is a function of age at exposure, x_e ,
- $\zeta(t, x_e)$ = the time since exposure ($t = x - x_e$) response function, can also be a function of x_e and
- $\gamma(x)$ = the age at expression response function.

The radiogenic risk models for bone, skin, and thyroid cancer in the current EPA methodology are all absolute risk models. In the previous methodology (i.e., for development of radionuclide slope factors prior to 1994), absolute risk models were used for leukemia and bone cancer only.

A relative risk model presumes that the age-specific excess force of mortality (or morbidity) due to a radiation dose is the product of an exposure-age-specific relative risk coefficient and baseline cancer mortality or incidence rates in the population. The model can be written as

where

$$\eta(x, x_e) = \beta(x_e) \zeta(t, x_e) \gamma(x) \quad (D-2)$$

- $\eta(x, x_e)$ = the relative risk (Gy^{-1}) at age x due to a dose at age x_e ($x > x_e$),
- $\beta(x_e)$ = the relative risk coefficient (Gy^{-1}), is a function of age at exposure, x_e ,
- $\zeta(t, x_e)$ = the time since exposure ($t = x - x_e$) response function, may also be a function of x_e and
- $\gamma(x)$ = the age at expression response function.

The radiogenic risk models for esophagus, stomach, colon, liver, lung, breast, ovary, bladder, kidney, leukemia, and residual cancer sites in the current EPA methodology are all relative risk models. In the pre-1994 methodology, relative risk models were used for all solid cancers considered (i.e., thyroid, breast, lung, esophagus, stomach, intestine, liver, pancreas, urinary, lymphoma, and residual cancer sites).

D.3 RISK MODELS

D.3.1 Risk model coefficients

Risk coefficients for the mortality risk models used in EPA's recently adopted methodology are shown in Table 3-1 of the main text. Absolute risk models are used for bone, skin, and thyroid cancers. Relative risk models are used for all other cancers. Corresponding risk coefficients for estimating attributable cancer incidence risk may be obtained by adjusting the mortality values by the appropriate lethality fraction for the cancer site of interest (see Table 3-1).

Risk coefficients for the pre-1994 methodology risk models are presented in Appendix C. Absolute risk models were used for leukemia and bone cancers, and relative risk models were used for all other cancer sites. Corresponding risk coefficients for estimating excess cancer incidence risk may be obtained by adjusting the mortality values by the appropriate lethality fraction shown in Table C-1 for the cancer site of interest.

D.3.2 Time since exposure response function

The time since exposure (TSE) response function for all cancers except bone, thyroid, and leukemia has a 10 y minimal latency period and a lifetime plateau, i.e.,

$$\begin{aligned} \zeta(t) &= 0, & t < 10 \\ &= 1, & 10 \leq t \end{aligned} \quad (D-3)$$

For bone cancer, a 2 y minimal latency period and a 25 y plateau period are assigned, i.e.,

$$\begin{aligned} \zeta(t) &= 0, & t < 2 \\ &= 1, & 2 \leq t < 27 \\ &= 0, & 27 \leq t \end{aligned} \quad (D-4)$$

For thyroid cancer, a 5 y minimal latency period and lifetime plateau are assigned, i.e.,

$$\begin{aligned} \zeta(t) &= 0, & t < 5 \\ &= 1, & 5 \leq t \end{aligned} \quad (D-5)$$

For leukemia, the TSE function developed by the NIH Working Group for the Radioepidemiology Tables (NIH85) is used. The Working Group fitted lognormal response functions for time since exposure greater than a minimal latency of 2 years to A-bomb survivor data for both chronic granulocytic leukemia (CGL) and acute leukemia (AL). These response functions can be expressed as follows:

$$\begin{aligned} \zeta(t, x_e) &= 0, & t < 2 \\ &= \phi(t, \xi(x_e), \sigma^2), & 2 \leq t \end{aligned} \quad (D-6)$$

where

$$\phi(t, \xi(x_e), \sigma^2) = \frac{\exp\left(-0.5(\ln(t-2) - \xi(x_e))^2 / \sigma^2\right)}{(t-2)\sqrt{2\pi}\sigma^2} \quad (D-7)$$

The values of $\xi(x_e)$ and σ^2 are 2.68 and 1.51, respectively, for CGL. For AL, they are the value of the expression $1.61+0.151x_e+0.0005x_e^2$ and 0.65, respectively. The total leukemia response function is a weighted mean of the CGL and AL response functions:

$$\zeta(t, x_e) = 0.32 \phi(t, \xi_{cgl}(x_e), \sigma_{cgl}^2) + 0.68 \phi(t, \xi_{al}(x_e), \sigma_{al}^2) \quad (D-8)$$

Since this TSE function has a maximum value that is much less than 1, the risk model coefficients for leukemia in Table 4.1 are much larger than those for other sites.

The time since exposure response function for the pre-1994 methodology risk models for all cancers except bone and leukemia had a 10 y minimal latency period and a lifetime plateau. For bone cancer and leukemia, a 2 y minimal latency period and a 25 y plateau period were assigned in the pre-1994 methodology.

D.3.3 Age at expression function

The age at expression function, $\gamma(x)$, is equal to one for all risk models and cancer sites in the current EPA methodology (also for the pre-1994 methodology).

D.4 RISK CALCULATIONS

D.4.1 Basic quantities

- $S(x)$, the survival function, is the fraction of live born individuals expected to survive to age x . $S(0)=1$, and decreases monotonically for increasing values of x . $S(x)$ is obtained by fitting a cubic spline to the decennial life table values to provide a continuous function of x .
- e is the expected lifespan at birth (age 0).
- $e(x)$ is the life expectancy (expected lifetime remaining) (years) for an individual who has attained age x . It is given by

$$e(x) = \frac{1}{S(x)} \int_x^{\infty} S(u) du . \quad (\text{D-9})$$

- $\mu(x)$ is the force of mortality or hazard rate (y^{-1}) at age x . Without a subscript, it is usually the total rate from all causes. A subscript is used (unless it is clear by context) to indicate a specific cause, i.e.,

$$\mu(x) = \sum_{\text{all } i} \mu_i(x) . \quad (\text{D-10})$$

- $S(x)$ is directly dependent on $\mu(x)$ since

$$S(x) = \exp\left(-\int_0^x \mu(u) du\right) . \quad (\text{D-11})$$

When the baseline force of mortality $\mu_0(x)$ is incremented by $\mu_i(x)$, $S(x)$ becomes

$$\begin{aligned} S(x) &= \exp\left(-\int_0^x (\mu_0(u) + \mu_i(u)) du\right) \\ &= S_0(x) S_i(x) , \end{aligned} \quad (\text{D-12})$$

where

$$S_0(x) = \exp\left(-\int_0^x \mu_0(u) du\right) , \quad (\text{D-13})$$

and

$$S_i(x) = \exp\left(-\int_0^x \mu_i(u) du\right) . \quad (\text{D-14})$$

For sufficiently small values of $\mu_i(x)$, $S_i(x)$ approaches a value of 1 for all values of x , i.e., $S_0(x)$ and $S(x)$ are essentially the same. For most environmental radiation risk assessment cases of practical interest, the increment of risk due to radiation satisfies this condition.

D.4.2 Attributable lifetime risk coefficient

The age-specific attributable lifetime risk (ALR) coefficient, $r(x)$, is the risk per unit dose of a subsequent cancer death (Gy^{-1}) due to radiation received at age x . For an absolute risk model, the asymptotic ALR coefficient is

$$r_i(x) = \frac{1}{S_0(x)} \int_x^\infty \epsilon_i(u) S_0(u) du . \quad (\text{D-15})$$

Similarly, for a relative risk model,

$$r_i(x) = \frac{1}{S_0(x)} \int_x^\infty \eta_i(u) \mu_i(u) S_0(u) du . \quad (\text{D-16})$$

These age-specific coefficients are principally used to calculate age-averaged coefficients and risks from radionuclide intakes or exposures.

D.4.3 Attributable lifetime loss coefficient

The attributable lifetime loss (ALL) coefficient $e(x)$, at age x , is the expected lifetime loss per unit dose (y Gy^{-1}) for a radiation dose at age x . For an absolute risk model, the asymptotic ALL coefficient is

$$e_i(x) = \frac{1}{S_0(x)} \int_x^\infty \epsilon_i(u) \ell(u) S_0(u) du . \quad (\text{D-17})$$

For a relative risk model,

$$e_i(x) = \frac{1}{S_0(x)} \int_x^\infty \eta_i(u) \mu_i(u) \ell(u) S_0(u) du . \quad (\text{D-18})$$

D.4.4 Age-averaged coefficients

The lifetime age-averaged risk and life loss coefficients are

$$\begin{aligned} \bar{r} &= \frac{\int_0^\infty r(x) S(x) dx}{\int_0^\infty S(x) dx} \\ &= \frac{\int_0^\infty r(x) S(x) dx}{\ell} , \end{aligned} \quad (\text{D-19})$$

and

$$\begin{aligned} \bar{e} &= \frac{\int_0^\infty e(x) S(x) dx}{\int_0^\infty S(x) dx} \\ &= \frac{\int_0^\infty e(x) S(x) dx}{\ell} , \end{aligned} \quad (\text{D-20})$$

respectively. Since the age distribution of a stationary population is proportional to $S(x)$, the stationary-population weighted average values are identical to the lifetime age-averaged ones. When the coefficients are averaged over a specific age interval, e.g., for assessing childhood or occupational exposures, the limits of integration in both the numerators and the denominators of these expressions are changed accordingly.

D.4.5 Sex-averaged coefficients

Since radiogenic cancer risk models are generally sex-specific, the resulting risk coefficients must be averaged for use in assessing risk to a combined population. This is accomplished by presuming a male:female sex ratio for live births of 1.051. Since $S(x)$ is sex-specific, the sex ratio is a function of age. The combined (sex-averaged) survival function is

$$S_c(x) = \frac{1.051 S_m(x) + S_f(x)}{2.051}, \quad (\text{D-21})$$

where the subscripts m, f , and c refer to the male, female, and combined values respectively.

Similarly, the expected combined lifetime is

$$e_c = \frac{1.051 e_m + e_f}{2.051}. \quad (\text{D-22})$$

The combined age-specific force of mortality must reflect the age-specific contribution of each sex. Hence,

$$\mu_c(x) = \frac{1.051 S_m(x) \mu_m(x) + S_f(x) \mu_f(x)}{1.051 S_m(x) + S_f(x)}. \quad (\text{D-23})$$

Combined age-specific ALR and ALL coefficients are

$$r_c(x) = \frac{1.051 S_m(x) r_m(x) + S_f(x) r_f(x)}{1.051 S_m(x) + S_f(x)}, \quad (\text{D-24})$$

and

$$e_c(x) = \frac{1.051 S_m(x) e_m(x) + S_f(x) e_f(x)}{1.051 S_m(x) + S_f(x)}. \quad (\text{D-25})$$

respectively. Combined age averaged ALR and ALL values must reflect the expected lifetime over the age interval. The lifetime average combined ALR and ALL coefficients are

$$r_c = \frac{1.051 e_m r_m + e_f r_f}{1.051 e_m + e_f}, \quad (\text{D-26})$$

and

$$e_c = \frac{1.051 \ell_m e_m + \ell_f e_f}{1.051 \ell_m + \ell_f} \quad (\text{D-27})$$

D.4.6 Continuity considerations

While the integration of a smoothly varying function using a spline is straightforward, the radiogenic cancer models are inherently discontinuous. For example, the time since exposure function for most solid cancers typically has a value of zero for times since exposure that are less than the 10 y minimal latency and a value of one for times equal to or greater than the minimal latency. Suppose that the function to be integrated (the integrand) is fitted at one year increments. For the Revised Methodology models, the function will change abruptly from a value of zero for times since exposure less than 10 y to a generally smoothly varying function of time for times equal to or greater than 10 years. However fitting a spline to the integrand provides a continuous transition from the value at 9 y to the value at 10 y. If the integral is evaluated on the basis of these spline coefficients, it will include an unintended contribution from this interval.

One way to solve the problem is to integrate functions in piece-wise continuous intervals. This method is exact and would work well for the simple example considered above. In general, however, the value of the integrand at each discontinuity depends on the interval of integration; the method becomes unwieldy for situations with many discontinuities. An alternative method for situations where the function is reasonably smooth on either side of a discontinuity is to replace the value of the function at the discontinuity with the average of the values immediately above and below it. For the case above, the value of the time since exposure response function at 10 y is changed from 1 to $(0+1)/2=0.5$. The reduced excess in the integral between 9 and 10 y is then compensated for by a comparable reduction in the 10 to 11 year interval. This discontinuity smoothing method was used to calculate the risks and lifetime losses for use in the development of radionuclide slope factors.

D.4.7 Cancer type and dose location associations

The dose locations associated with each cancer type are shown in Table D-1. When more than one dose location is shown in the table, risks are calculated for a weighted mean of the doses at these locations using the weights shown in the table. The residual cancer category represents a composite of primary and secondary cancers that are not otherwise considered in the model. The dose location associated with these cancers, the pancreas, was chosen to be generally representative of soft tissues; the pancreas is not considered the origin of all these neoplasms.

Table D-1. Target organs and tissues used by EPA for calculation of cancer risk

Cancer Site	Dose Tissue (target organ)	Weighting Factor
EPA Revised Methodology		
Esophagus	Thymus	1.0
Stomach	Stomach wall	1.0
Colon	Upper large intestine wall	0.5
	Lower large intestine wall	0.5
Liver	Liver	1.0
Lung	Tracheo-bronchial region	0.8
	Pulmonary region	0.2
Bone	Bone surface	1.0
Skin	Skin (dermis)	1.0
Breast	Female breast	1.0
Ovary	Ovary	1.0
Bladder	Urinary bladder wall	1.0
Kidney	Kidney	1.0
Thyroid	Thyroid	1.0
Leukemia	Red bone marrow	1.0
Residual	Pancreas	1.0
EPA Pre-1994 Methodology		
Leukemia	Red bone marrow	1.0
Bone	Bone surface	1.0
Thyroid	Thyroid	1.0
Breast	Breast	1.0
Lung	Pulmonary region	1.0
Esophagus ¹	-	-
Stomach	Stomach wall	1.0
Intestine	Small intestine wall	0.2
	Upper large intestine wall	0.4
	Lower large intestine wall	0.4
Liver	Liver	1.0
Pancreas	Pancreas	1.0
Urinary ²	Kidney ²	0.5
	Urinary bladder wall	0.5
Lymphoma ¹	-	-
Other	Pancreas	1.0

¹ Included in "Other".

² Prior to 1992, urinary cancer risk was calculated based on the kidney dose rates only, even when the dose to bladder was much lower, which led to overestimates of urinary cancer risk for certain radionuclides.

D.4.8 Cancer incidence calculations

While the calculational methodology outlined above could be used with incidence models and force of morbidity data, the method used for the Revised Methodology is to divide the mortality risk coefficient by a corresponding lethality factor, k , shown in Table 3-4. An exception is made for skin; only mortality is considered for calculating skin cancer incidence, i.e., k is considered to be 1. The lifetime loss coefficient is not recalculated for incidence.

D.5 BASELINE FORCE OF MORTALITY CALCULATIONS

Age-specific mortality rates (force of mortality) were calculated at one year intervals using U.S. mortality data for the period 1979-1981 (NCHS82, 83, 84). These calculations assume that the fraction of the recorded deaths in each age group due to a given cause, e.g., a specific ICD code, is the same as the probability of death in that age interval for a birth cohort with the corresponding age-specific death rate. In summary,

Let: n_i be the number of deaths due to all causes between ages x_{i-1} and x_i ,
 n_{ij} be the number of deaths due to cause j between ages x_{i-1} and x_i ,
 m_i be the probability in a birth cohort of dying from all causes between ages x_{i-1} and x_i ,
 m_{ij} be the probability in a birth cohort of dying from cause j between ages x_{i-1} and x_i .

Then, given the age-specific forces of mortality, $\mu(x)$ and $\mu_j(x)$, and the survival function, $S(x)$,

$$m_i = \int_{x_{i-1}}^{x_i} \mu(x) S(x) dx = S(x_{i-1}) - S(x_i) , \quad (D-28)$$

and

$$\begin{aligned} m_{ij} &= \int_{x_{i-1}}^{x_i} \mu_j(x) S(x) dx & (D-29) \\ &= \frac{n_{ij} m_i}{n_i} \\ &= \frac{n_{ij}}{n_i} [S(x_{i-1}) - S(x_i)] . \end{aligned}$$

(For $i=0$, x_i , n_i , n_{ij} , m_i , and m_{ij} are all equal to 0 as well.) Let $M_j(x_i)$ be the probability in a birth cohort of dying from cause j by age x_i , i.e.,

$$\begin{aligned}
 M_j(x_i) &= \int_0^{x_i} \mu_j(x) S(x) dx & (D-30) \\
 &= \sum_{k=0}^i m_{kj} .
 \end{aligned}$$

Differentiating the expression for $M_j(x)$ with respect to x ,

$$\frac{dM_j(x)}{dx} = \mu_j(x) S(x) . \quad (D-31)$$

Solving for the force of mortality,

$$\mu_j(x) = \frac{1}{S(x)} \frac{dM_j(x)}{dx} . \quad (D-32)$$

Hence, point estimates of $\mu_j(x)$ can be calculated by fitting a spline to $M_j(x)$, calculating its derivative with respect to x from the spline coefficients, and dividing the derivative by the value of the survival function at x .

D.6 RADIONUCLIDE RISK COEFFICIENTS

D.6.1 Radiogenic Risk from Internal Exposure

D.6.1.1 Age-specific radionuclide risk calculations. The age-specific cancer risk attributable to a unit intake of a radionuclide (Bq^{-1}) is calculated from the absorbed dose rate due to a unit intake of activity and the age-specific risk per unit dose coefficient. The calculation is specific for each cancer and associated absorbed dose site in the risk model. The complete calculation may involve the sum of contributions from more than one tissue (see Table D-1) and from both low- and high-LET absorbed doses. (Except for leukemia, the Revised Methodology radiogenic cancer risk relative biological effectiveness (RBE) for a high-LET absorbed dose from alpha radiation is 20 times that for a low dose, low dose rate, low-LET absorbed dose; for leukemia, the alpha dose RBE is 1. Previously the EPA methodology assigned a RBE of 8 to the high-LET absorbed dose from alpha radiation for all cancers; in 1992, the high-LET RBE for leukemia was revised from 8 to 1.117.) Each risk contribution is calculated as follows:

$$r_a(x_i) = \frac{1}{S(x_i)} \int_{x_i}^{110} d(x) r(x) S(x) dx , \quad (D-33)$$

where

- $r_a(x_i)$ = the cancer risk coefficient (Bq^{-1}) for a unit intake of activity at age x_i ,
 $d(x)$ = the absorbed dose rate ($Gy\ y^{-1}$) at the site at age x due to a unit intake of activity at age x_{iii} ,
 $r(x)$ = the cancer risk due to a unit absorbed dose (Gy^{-1}) at the site at age x , and
 $S(x)$ = the survival function at age x .

The integration is terminated at 110 years due to the characteristics of the survival function, i.e., no member of the exposed population is assumed to live more than 110 years.

D.6.1.2 Sex-averaged risk coefficient. Age-specific male and female risk coefficients are combined by calculating a weighted mean:

$$r_a(x_i) = \frac{1.051 r_{ma}(x_i)S_m(x_i) + r_{fa}(x_i)S_f(x_i)}{1.051 S_m(x_i) + S_f(x_i)}, \quad (D-34)$$

where

- $r_a(x)$ = the combined cancer risk coefficient (Bq^{-1}) for a unit intake of activity at age x_i ,
 1.051 = the presumed sex ratio at birth (male:female),
 $r_{ma}(x)$ = the male risk per unit activity at age x_i ,
 $r_{fa}(x)$ = the female risk per unit activity at age x_i ,
 $S_m(x_i)$ = the male survival function at age x_i , and
 $S_f(x_i)$ = the female survival function at age x_i .

This formulation weights each sex-specific risk coefficient by the proportion of that sex in a stationary combined population at the desired age of intake.

D.6.1.3 Lifetime average radionuclide risk coefficient. The lifetime average risk coefficient (Bq^{-1}) for a unit lifetime intake of a radionuclide at a constant intake rate is calculated from the age-specific value by the equation:

$$\bar{r}_a = \frac{\int_0^{110} r_a(x)S(x) dx}{\varrho}, \quad (D-35)$$

where

- \bar{r}_a (Bq^{-1}) = the average lifetime risk per unit intake of activity, and
 ϱ = the expected lifetime at age 0.

The stationary-population weighted average risk per unit intake of activity is also r_a . The sex-weighted average is given by

$$\bar{r}_a = \frac{1.051 \bar{r}_{ma} \varrho_m + \bar{r}_{fa} \varrho_f}{1.051 \varrho_m + \varrho_f} \quad (D-36)$$

D.6.2 Radiogenic Risk from External Exposure

Risk coefficients for external radiation exposure pathway are calculated in a manner analogous to that presented for internal exposure pathways in Section D.6.1. External exposure risks are calculated based on the absorbed dose rate attributable to a chronic exposure to a unit concentration of the radionuclide of interest uniformly distributed in contaminated soil, rather than the unit intake considered for internal exposures. The calculation is specific for each cancer and associated absorbed dose site in the risk model, and may involve the sum of contributions from more than one tissue. For the external exposure pathway, only low-LET absorbed doses are considered.

The lifetime average risk coefficient [(Bq/g)⁻¹] for a lifetime exposure to a unit concentration of a radionuclide uniformly distributed in soil is calculated from the age-specific value by the equation:

$$\bar{r}_a = \frac{\int_0^{110} r_a(x) S(x) dx}{\varrho} \quad (D-37)$$

where

\bar{r}_a (Bq⁻¹) = the average lifetime risk per unit concentration of activity in soil, and
 ϱ = the expected lifetime at age 0, as defined above.

Sex-averaged risk coefficients are calculated in the same manner as for internal exposure pathways, based on a male:female ratio of 1.051.

D.7 RADIONUCLIDE SLOPE FACTOR CALCULATION

For each radionuclide and exposure pathway, the slope factor, SF, is computed as the summation of the individual cancer risks, \bar{r}_a , described above:

$$SF = \sum \bar{r}_a \quad (D-38)$$

where

\bar{r}_a (Bq⁻¹) = the average lifetime risk per unit intake of activity (for internal exposures) or per unit radionuclide concentration in soil (for external exposure) for cancer site a,

SF = (Bq^{-1} for internal exposure pathways, (Bq/g) for external exposure) is the radionuclide slope factor for the given radionuclide and exposure pathway of interest, and the summation is performed over all cancer sites.

D.8 REFERENCES

- Ch80 Chiang, C.L., An Introduction to Stochastic Processes and Their Applications, Robert E. Krieger Publishing Company, Inc., Huntington, NY, 1980.
- Co78 J.R. Cook, B.M. Bunger, and M.K. Barrick, A Computer Code for Cohort Analysis of Increased Risks of Death (CAIRD), EPA 520/4-78-012, U.S. EPA, June 1978.
- de78 de Boor, C., A Practical Guide to Splines, Applied Mathematical Sciences Vol. 27, Springer-Verlag, New York, NY, 1978.
- Du80 Dunning, D.E. Jr., Leggett, R.W., and Yalcintas, M.G., A Combined Methodology for Estimating Dose Rates and Health Effects from Exposure to Radioactive Pollutants, ORNL/TM-7105, 1980.
- EPA94 Environmental Protection Agency, Estimating Radiogenic Cancer Risks, J.S. Puskin and C.B. Nelson, Office of Radiation and Indoor Air, EPA 402-R-93-076, June 1994.
- Fr82 Fritsch, F.N. and J. Butland, A Method for Constructing Local Monotone Piecewise Cubic Interpolants, UCRL-87559, Lawrence Livermore National Laboratory, April 1982.
- NAS90 National Academy of Sciences - National Research Council, Health Effects of Exposure to Low Levels of Ionizing Radiation - BEIR V, National Academy Press, Washington, DC, 1990.
- NCHS82 National Center for Health Statistics, Vital Statistics Mortality Data, Detail, 1979, PB82-132340, U.S. Department of Health and Human Services, Public Health Service, National Center for Health Statistics, Hyattsville, MD, 1982.
- NCHS83 National Center for Health Statistics, Vital Statistics Mortality Data, Detail, 1980, PB83-261545, U.S. Department of Health and Human Services, Public Health Service, National Center for Health Statistics, Hyattsville, MD, 1983.
- NCHS84 National Center for Health Statistics, Vital Statistics Mortality Data, Detail, 1981, PB84-213008, U.S. Department of Health and Human Services, Public Health Service, National Center for Health Statistics, Hyattsville, MD, 1984.
- NCHS85 National Center for Health Statistics, U.S. Decennial Life Tables for 1979-1981, Vol. 1 No. 1, United States Life Tables, (PHS) 85-1150-1, U.S. Department of Health and Human Services, Public Health Service, National Center for Health Statistics, Hyattsville, MD, August 1985.
- NIH85 National Institutes of Health, Report of the National Institutes of Health Ad Hoc Working Group to Develop Radioepidemiological Tables, NIH Publication No. 85-2748, U.S. Government Printing Office, Washington, DC 20402, p 92, 1985.

- PHS80 Public Health Service, The International Classification of Diseases, 9th Revision, Clinical Modification (ICD-9-CM), Vol. 1 Diseases: Tabular List, DHHS Publication No. (PHS) 80-1260, U.S. Department of Health and Human Services, Public Health Service—Health Care Financing Administration, Superintendent of Documents, U.S. Government Printing Office, Washington, DC, 1980.
- Sj94 Sjoreen, A.L., Reconstruction of the RADRISK Database, Oak Ridge National Laboratory, Oak Ridge, TN, (to be published) 1994.
- Va89 Vaeth, M. and D.A. Pierce, Calculating Excess Lifetime Risk in Relative Risk Models, RERF CR 3-89, Editorial Office, Radiation Effects Research Foundation, Hiroshima, Japan, November 1989.

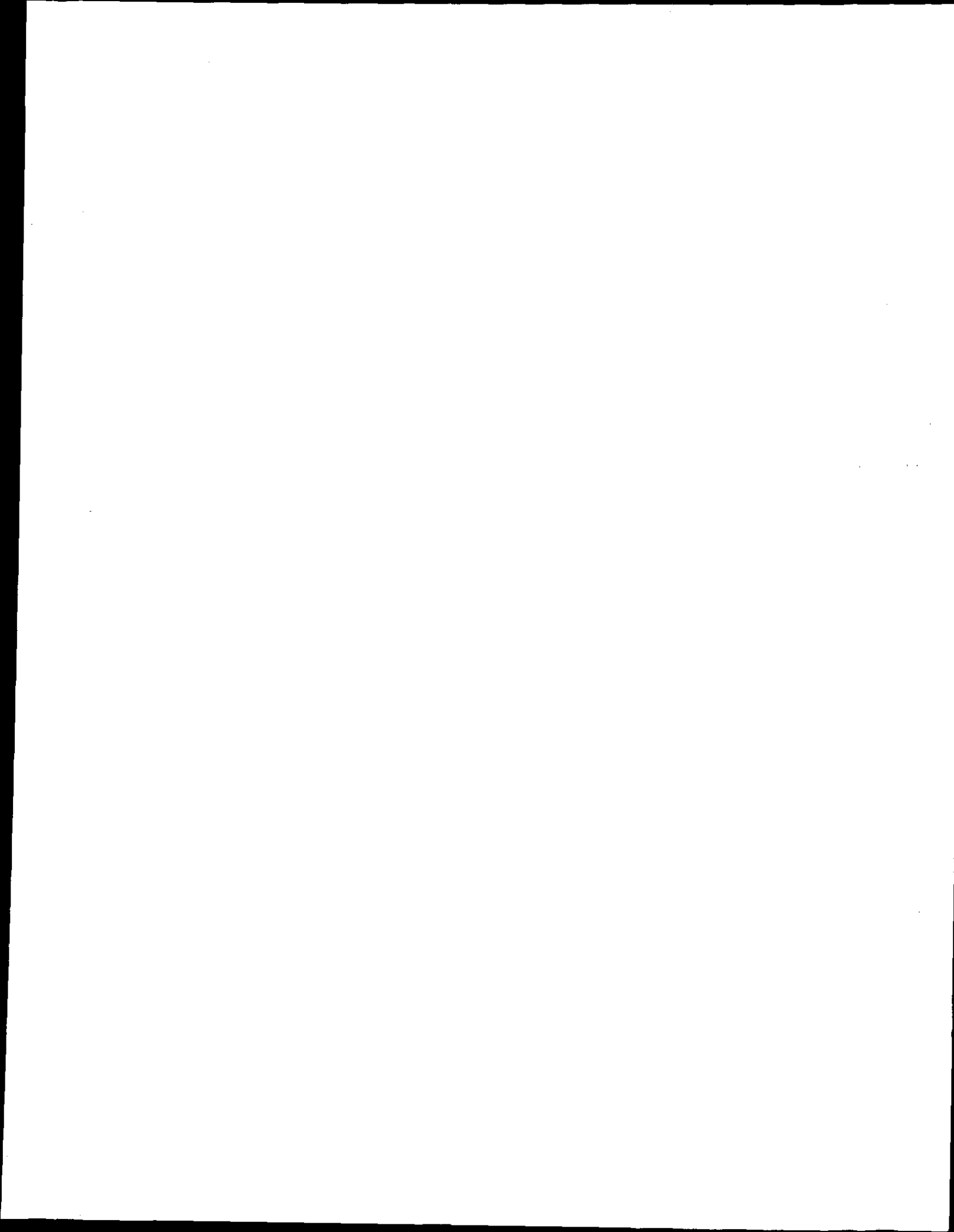

The first part of the document discusses the importance of maintaining accurate records of all transactions. It emphasizes that every entry, no matter how small, should be recorded to ensure the integrity of the financial statements. This includes not only sales and purchases but also expenses, income, and transfers between accounts.

The second part of the document provides a detailed explanation of the accounting cycle. It outlines the ten steps involved in the process, from identifying the accounting entity to preparing financial statements. Each step is described in detail, with examples provided to illustrate the concepts.

The third part of the document discusses the various types of accounts used in accounting. It explains the difference between assets, liabilities, and equity accounts, and how they are classified. It also discusses the importance of understanding the normal balances for each type of account.

The fourth part of the document discusses the process of adjusting entries. It explains why adjustments are necessary and how they are recorded. It provides examples of common adjusting entries, such as depreciation, amortization, and accruals.

The fifth part of the document discusses the preparation of financial statements. It explains how the adjusted trial balance is used to prepare the income statement, balance sheet, and statement of owner's equity. It also discusses the importance of comparing the results of the financial statements to the company's performance.

The sixth part of the document discusses the closing process. It explains how the temporary accounts (revenues, expenses, and dividends) are closed to the permanent accounts (retained earnings). It provides a step-by-step guide to the closing process.

The seventh part of the document discusses the importance of internal controls. It explains how internal controls help to prevent errors and fraud, and how they can be designed to protect the company's assets.

The eighth part of the document discusses the role of the accountant. It explains the various responsibilities of an accountant, including recording transactions, preparing financial statements, and providing advice to management.

The ninth part of the document discusses the importance of ethics in accounting. It explains how accountants are expected to act in a fair and honest manner, and how they can avoid conflicts of interest.

The tenth part of the document discusses the future of accounting. It explains how technology is changing the way accountants work, and how accountants can stay up-to-date on the latest developments in the field.

Radionuclide Table: Radionuclide Carcinogenicity - Slope Factors

Data Source US EPA Federal Guidance Report No. 13 Morbidity Risk Coefficients, in Units of Picocuries

Revision #2

File: 8319.xlsx
20/08/2020

HBTOM

The curie (Ci) is the customary unit of activity and is equal to 3.7×10^{10} nuclear transformations per second.
Handbook of the Toxicology of Metals (Nordberg ET AL) 4th Edition

NOTE:

US EPA Regulates radium in drinking water to no more than 5 pCi of combined radium-226 and radium 228 per litre of water.

Slope Factor Morbidity Risk Coefficient
Lifetime excess Total Cancer Risk

Element	Kalbar Analysis	Element (Atomic Number)	HBTOM * Reference Pagess	Isotope	Radioactive Half Life (Years)	ICRP Lung Type	Gi Absorption Factor (f ₁) ⁹	Water Ingestion (Risk/pCi)	Food Ingestion (Risk/pCi)	Soil Ingestion (Risk/pCi)	Inhalation Risk (Risk/pCi)	External Exposure (Risk/y per pCi/g)	
Aluminium	260-4500 mg/kg	13	549-560	Al-26	716000	M	0.0100	0.001730	2490	0.47000	0.000000000069	0.0000133	
				Al-28	2.240							0.0000092	
Antimony	<0.5 mg/kg Carcinogen		565-572	Sb 115	31.80	M	0.1000	0.00000000000051	0.00000000000001	0.11600	0.00000000000002	0.0000039	
				Sb 116	15.80	M	0.1000	0.00000000000051	0.00000000000001	0.11600	0.00000000000002	0.0000105	
		51		Sb-126	12.40	M	0.10000	0.000000000001	0.000000000002	0.29	0.000000000115	0.00000649	
				Sb 127	3.85	M	0.1000	0.000000000001	0.000000000147	0.00000000003	0.00000000008	0.00000307	
Arsenic	61-491 mg/kg Carcinogen	33	582-610	As-69	15.20	M	0.50	0.00000000000105	0.00000000000015	0.2390	0.00000000000004	0.00000443	
				As-70	52.60	M	0.50	0.00000000000320	0.00000000000045	0.000000000001	0.000000000014	0.0000196	
				As-71	64.80	M	0.50	0.00000000000320	0.000000000003	0.000000000001	0.0000000000152	0.00000237	
				As-72	26.00	M	0.50	0.10	0.000000000001	0.000000000003	0.000000000004	0.00000000004	0.0000082
				As-73	80.30	M	0.50	0.000000000002	0.000000000002	0.000000000004	0.000000000004	0.00000000004	0.00000006
				As-74	17.80	M	0.50	0.000000000007	0.000000000010	0.000000000002	0.000000000001	0.00000000001	0.0000034
				As-76	26.30	M	0.50	0.000000000010	0.000000000001	0.000000000003	0.000000000000	0.00000000000	0.0000020
				As-77	38.80	M	0.50	0.000000000003	0.000000000004	0.000000000001	0.000000000002	0.000000000002	0.000000036
				As-78	90.70	M	0.50	0.000000000006	0.000000000009	0.000000000001	0.000000000003	0.000000000003	0.0000061
Thorium	1.0 -120 mg/kg Carcinogen	90		Th-226	30.90	m S	0.001	0.000000000001	0.00000000000923	0.0000000000016	0.00000000016	0.00000002	
				Th-227	18.70	d S	0.0005	0.000000000005	0.000000000005	0.00000000007	0.00000000014	0.0000004	
				Th-228	1.91	y S	0.001	0.0000000001	0.0000000001	0.00000000029	0.00000013	0.00000001	
				Th-228+D	1.91	y S	0.001	0.0000000003	0.0000000004	0.00000000081	0.00000014	0.00000076	
				In Kalbar ore body	Th-229	7340.00	y S	0.001	0.0000000002	0.0000000003	0.00000000050	0.00000018	0.00000023
				See pages 38-40 of TENORM Handbook	Th-229+D	7340.00	y S	0.001	0.0000000005	0.0000000007	0.0000000129	0.00000023	0.00000117
					Th-230	77000.00	y S	0.001	0.0000000001	0.000000000119	0.00000000020	0.00000003	0.00000000
					Th-231	25.50	h S	0.001	0.0000000000	0.00000000003	0.00000000001	0.00000000002	0.00000002
				Decays to Radium 228	Th-232	14 Billion Years	y S	7340.00	0.0000000001	0.000000000133	0.00000000023	0.00000004	0.000000003
					Th-234	24.10	d S	0.001	0.0000000000	0.00000000034	0.0000000007	0.0000000003	0.00000002
Tin	1.7 mg/kg	50	1242-1276	Sn-110	4.00	h M	0.020	0.000000000019	0.000000000003	0.000000000005	0.0000000000067	0.000001130	
				Sn-111	35.30	m M	0.020	0.000000000019	0.0000000000008	0.000000000000	0.000000000003	0.000002290	
				Sn-113	115.00	d M	0.020	0.000000000019	0.000000000006	0.000000000012	0.0000000001000	0.000000020	
				Sn-117m	13.60	d M	0.020	0.000000000019	0.000000000001	0.000000000013	0.0000000000884	0.000000469	
				Sn-119m	293.00	d M	0.020	0.000000000019	0.000000000003	0.000000000006	0.0000000000781	0.000000001	
				Sn-121	27.10	h M	0.020	0.000000000019	0.000000000015	0.000000000004	0.000000000102	0.000000000	
				Sn-121m	55.00	y M	0.020	0.000000000019	0.000000000023	0.000000000007	0.0000000001540	0.000000001	
				Sn-123	129.00	d M	0.020	0.000000000019	0.000000000140	0.000000000040	0.0000000003030	0.000000039	
				Sn-123m	40.10	m M	0.020	0.000000000019	0.0000000000001	0.000000000000	0.0000000000006	0.000000462	
				Sn-125	9.64	d M	0.020	0.000000000019	0.0000000000201	0.000000000058	0.0000000001410	0.000001530	
				Sn-126	100000.00	y M	0.020	0.000000000019	0.0000000000256	0.000000000071	0.0000000009950	0.00000100	
				Sn-127	2.10	h M	0.020	0.000000000019	0.000000000008	0.000000000002	0.0000000000044	0.000009250	
				Sn-128	59.10	m M	0.020	0.000000000019	0.000000000004	0.000000000001	0.0000000000023	0.000002620	
				Titanium	44-154 mg/kg Carcinogen	22		Ti-44	47.30	S	0.01000	0.000000000026	0.000000000004
Ti-45	3.08	S	0.0100					0.000000000006	0.000000000009	0.000000000018	0.00000000003	0.00000379	
Tungsten	<1 mg/Kg	74		W-176	2.30	h F	0.3000	0.000000000004	0.000000000001	0.000000000011	0.0000000001	0.00000032	

			W-177	135.00	m F	0.3000	0.0000000000002	0.000000000000	0.0000000000005	0.0000000000001	0.00000363
			W-178	21.70	d	0.3000	0.0000000000012	0.300000000000	0.0000000000033	0.0000000000004	0.00000002
			W-179	37.50	m F	0.3000	0.0000000000000	0.000000000000	0.0000000000000	0.0000000000000	0.00000006
			W-181	121.00	d F	0.3000	0.0000000000004	0.0000000000001	0.0000000000011	0.0000000000001	0.00000005
			W-185	75.10	d F	0.3000	0.0000000000029	0.0000000000004	0.0000000000084	0.0000000000009	0.00000000
			W-187	23.90	h F	0.3000	0.0000000000037	0.0000000000005	0.0000000000103	0.0000000000011	0.00000204
			W-188	69.40	d F	0.3000	0.0000000000140	0.0000000000021	0.0000000000400	0.0000000000005	0.00000001
Uranium	3-9 mg/kg	234	U-230	20.80	d M	0.0200	0.0000000002090	0.0000000002980	0.0000000005660	0.0000000455000	0.000000003
			U-231	4.20	d M	0.0200	0.0000000000018	0.0000000000026	0.0000000000050	0.0000000000018	0.00000016
			U-232	72.00	y M	0.0200	0.0000000002920	0.0000000003850	0.0000000005740	0.0000000195000	0.000000001
			U-233	159000	y M	0.0200	0.0000000000718	0.0000000000969	0.0000000001600	0.0000000116000	0.000000000
			U-234	245000.00	y M	0.0200	0.0000000000707	0.0000000000955	0.0000000001580	0.0000000114000	0.000000000
			U-235	704000000	y M	0.0200	0.0000000000696	0.0000000000944	0.0000000001570	0.0000000101000	0.000000052
			U-235+D	704000000	y M	0.0200	0.0000000000718	0.0000000000976	0.0000000001630	0.0000000101000	0.000000054
			U-236	234000000	Y M	0.0200	0.0000000000670	0.0000000000903	0.0000000001490	0.0000000105000	0.000000000
			U-237	6.75	d M	0.0200	0.0000000000049	0.0000000000071	0.0000000000139	0.0000000000064	0.000000038
			U-238	4470000000	y M	0.0200	0.0000000000640	0.0000000000866	0.0000000001430	0.0000000093200	0.000000000
			U-238+D	4470000000	y M	0.0200	0.0000000000871	0.0000000001210	0.0000000002100	0.0000000093500	0.000000011
			U-239	23.50	m M	0.0200	0.0000000000001	0.0000000000001	0.0000000000002	0.0000000000001	0.000000012
			U-240	14.10	h M	0.0200	0.0000000000070	0.0000000000103	0.0000000000202	0.0000000000030	0.000000000
Vanadium	17-130 mg/kg		V-47	32.60	m M	0.0100	0.0000000000001	0.0000000000002	0.0000000000003	0.0000000000001	0.00000436
	Carcinogen		V48	16.20	d M	0.0100	0.0000000000081	0.0000000000117	0.0000000000213	0.0000000000093	0.00001400
			V49	330.00	d M	0.0100	0.0000000000001	0.0000000000002	0.0000000000004	0.0000000000001	0.000000000
Zirconium	6,250-42,750 mg/kg	40	Zr-97	16.90	m	0.0100	0.0000000000125	0.0000000000183	0.0000000000375	0.0000000000005	0.0000008620
		70kg Male	Inhalation of	17800 M ³	Per Day						

